

KOMATSU®

930E-4

MAXIMUM GVW
501974 kg **1,106,670 lb**

GROSS HORSEPOWER
2014 kW **2,700 HP**

930E

ELECTRIC DRIVE TRUCK



Photos may include optional equipment

SPECIFICATIONS



ENGINE

Make and model	Komatsu SSDA16V160*
Fuel	Diesel
Number of cylinders	16
Operating cycle	4 cycle
Rated brake power**	2014 kW 2,700 HP @ 1900 rpm
Flywheel power***	1902 kW 2,550 HP @ 1900 rpm
Weight (wet)	9608 kg 21,182 lb

* Tier 2 emissions compliant. Tier 1 emissions engine is optional outside of North America.

** Rated brake power is the output of the engine as installed in this machine, at governed rpm and with engine manufacturer's approved fuel setting. Accessory losses included are water pump, fuel pump and oil pump.

*** Flywheel power is the rated power at the engine flywheel minus the average accessory losses. Accessories include fan and charging alternator. Rating(s) represent net engine performance in accordance with SAE J1349 conditions.



ELECTRIC DRIVE

AC/DC CURRENT

Alternator	GTA-41
Dual impeller in-line blower	340 m ³ /min 12,000 cfm
Control	AC Torque Control System
Motorized wheels*	GDY106 Induction Traction Motors
Ratio**	32.62:1
Speed (maximum)	64.5 km/h 40 mph

* Wheel motor application depends upon gross vehicle weight, haul road grade, haul road length, rolling resistance and other parameters. Komatsu and G.E. must analyze each job condition to assure proper application.

** Optional ratios available.



TIRES AND RIMS

Rock service, tubeless, radial tires

Standard tire* 53/80 R63

Taper lock, five (5) piece rim

914 mm x 1600 mm x 127 mm **36" x 63" x 5.0"** rim assembly.

Rims rated at 758 kPa **110 psi** cold inflation pressure.

Typical tire weight 26127 kg **57,600 lb**

* Tires should meet application requirements for tkph/tmph, tread, compound, inflation pressure, ply rating or equivalent, etc.



BODY

All-welded steel flat floor body with horizontal bolsters and full canopy. Eyebrow, rear wheel rock ejectors, body up sling and rubber mounts on frame are standard. Pivot exhaust heating optional.

Floor sheet 16 mm **0.63"** 1379 mPa **200,000 psi**
tensile strength steel (two-piece)

Front sheet 9 mm **0.35"** 1379 mPa **200,000 psi**
tensile strength steel

Side sheet 8 mm **0.31"** 1379 mPa **200,000 psi**
tensile strength steel

Canopy sheet 5 mm **0.19"** 690 mPa **100,000 psi**

Struck 171 m³ **224 yd³**

Standard SAE heaped 2:1 211 m³ **276 yd³**

Standard Komatsu body weight 30362 kg **66,936 lb**

*Komatsu must approve all bodies through a Body Application Worksheet



CAB

Advanced Operator Environment with integral 4-post ROPS/FOPS structure Level 2, adjustable air suspension seat w/lumbar support and arm rests, full-size passenger seat, maximum R-value insulation, tilt and telescoping steering wheel, electric windshield wipers w/washer, tinted safety glass, power windows, Komatsu Payload Weighing System, 55,000 Btu/hr heater and defroster, 21,600 BTU/hr air conditioning (HFC - 134A refrigerant).



FRAME

Advanced technology, full butt-welded box sectional ladder-type frame with integral ROPS supports, integral front bumper, rear tubular cross members, steel castings at all critical stress transition zones, rugged continuous horseshollar.

Plate material 482.6 mPa **70,000 psi**
tensile strength steel

Casting material 620.5 mPa **90,000 psi**
tensile strength steel

Rail width 305 mm **12"**

Rail depth (minimum) 864 mm **34"**

Top and bottom plate thickness 45 mm **1.77"**

Side plate thickness 25 mm **0.98"**

Drive axle mounting Pin and spherical bushing

Drive axle alignment Swing link between frame and axle



BRAKING SYSTEM

Service brakes: oil-cooled, hydraulic-actuated, multiple disc brakes at each wheel. Traction system wheel slip/slide control.

Max. service apply pressure 17237 kPa **2500 psi**

Total friction area per brake 97025 cm² **15,038 in²**

Emergency brakes Automatically applied prior
to hydraulic system pressure dropping below level
required to meet secondary stopping requirements.

Wheel brake locks Switch activated

Parking brakes Multiple disc, spring-applied,
hydraulically-released, dry brakes on inboard end
of each wheel motor rotor shaft. Rated to hold on
±15% grade at maximum gross vehicle weight.

Electric dynamic retarder Max 4026 kW **5400 hp**
Continuous 2460 kW **3300 hp**

Continuously rated high-density blown grids w/retard capacity at low speeds and retard in reverse propulsion.



SUSPENSION

Variable rate hydro-pneumatic with integral rebound control

Max. front stroke 328 mm **12.92"**

Max. rear stroke 239 mm **9.40"**

Max. rear axle oscillation ±6.5°



COOLING SYSTEM

L&M radiator assembly, split-flow, with deaerator-type top tank.

Radiator frontal area 7.02 m² **75.5 ft²**



SERVICE CAPACITIES

Cooling system 594 L . . . **157 U.S. gal**

Crankcase* 280 L . . . **74 U.S. gal**

Hydraulic system 1325 L . . . **350 U.S. gal**

Motor gear box (each) 95 L . . . **25 U.S. gal**

Fuel 4542 L . . . **1200 U.S. gal**

* Includes lube oil filters



DIMENSIONS

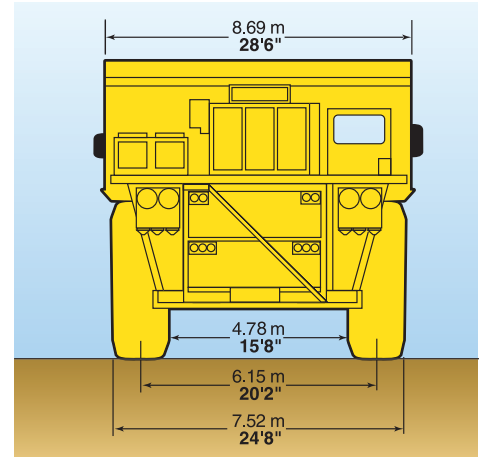
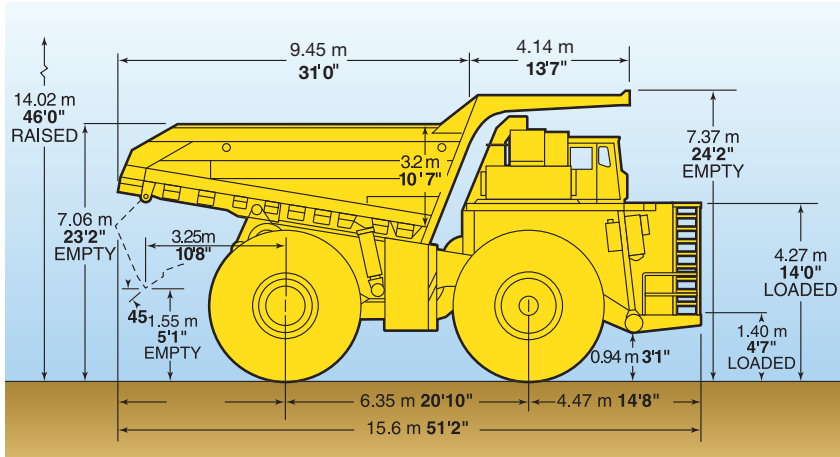

All dimensions are with 211 m³ 276 yd³ body.

Bodies	Struck	2:1 Heap	Loading Height*
Standard	171 m ³ 224 yd ³	211 m ³ 276 yd ³	7.06 m 23'2"

*Exact load height may vary due to tire make, type, and inflation pressure.

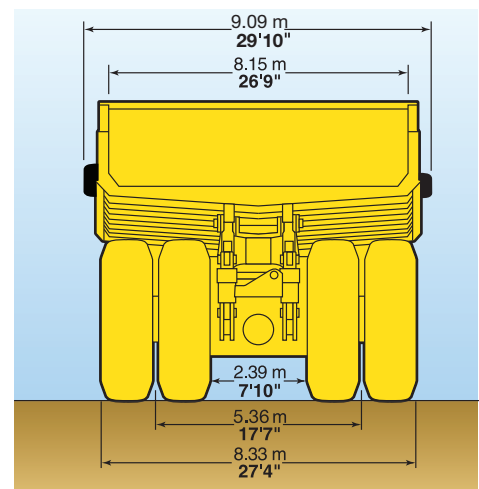

HYDRAULIC SYSTEM

Steering Accumulator assisted with twin double acting cylinders provide constant rate steering. Emergency steering automatically supplied by accumulator.

Turning circle diameter (SAE) 29.7 m 97'7"

Reservoir 947 L 250 U.S. gal

Filtration In-line replaceable elements

Suction Single, full flow, 100 mesh

Hoist and steering Dual, in-line, high pressure

Brake component cabinet Above deck, easily accessible with diagnostic test connections

Hoist Two 3-stage dual-acting outboard cylinders, internal cushion valve, over-center dampening

Hoist times

Power-up loaded 21 sec

Power-down 23 sec

Float-down empty 24 sec

Pumps Two pumps, single package, end of alternator

Hoist and brake cooling Tandem gear pump with output of 1022 lpm **270 gpm** at 1900 rpm and 17237 kPa **2,500 psi**

Steering and brake Pressure-compensating piston pump with output of 246 lpm **65 gpm** at 1900 rpm and 18961 kPa **2,750 psi**

System relief pressures

Hoist and brake cooling 17237 kPa **2,500 psi**

Steering and brake 27579 kPa **4,000 psi**

Quick disconnects standard for powering disabled truck and for systems diagnostics.



ELECTRICAL SYSTEM

4 x 8D 1450 CCA, 12 volt, in series/parallel, 220-ampere-hour batteries, bumper-mounted with disconnect switch and lockout.

Alternator 24 volt, 140 amp

Lighting 24 volt

Cranking motors Two/24 volt



WEIGHT DISTRIBUTION

Empty vehicle weight (wet, 100% fuel, no options, std. Komatsu body, std. tires)

Front axle 99711 kg . . . **219,826 lb** 47%

Rear axle 110476 kg . . . **243,557 lb** 53%

Total EVW 210187 kg . . . **463,383 lb**

Gross vehicle weight (Nominal)

Front axle 165651 kg . . . **365,201 lb** 33%

Rear axle 336323 kg . . . **741,469 lb** 67%

Total 501974 kg . . . **1,106,670 lb**

Nominal payload* 291790 kg . . . **643,287 lb**

320 U.S. ton

* Nominal payload is defined by Komatsu America Corp. payload policy documentation. In general, the nominal payload must be adjusted for the specific vehicle configuration and site application. The figures above are provided for basic product description purposes. Please contact your Komatsu distributor for specific application requirements.



STANDARD EQUIPMENT

- Air cleaners, Donaldson SRG
- Air filter evacuators
- Alternator (24 volt/140A)
- Auto lubrication system w/ground level fill & level indicator
- Batteries—4 x 8D (1450 CCA's)
- Battery charging cable and socket
- Body over center device
- Brakes: oil-cooled, multiple disc front & rear
- Control cabinet
- Electric start
- Eliminator, Centinel, reserve oil tank
- Filters, high pressure hydraulic
- Gate valves on hydraulic tank
- Ground level radiator fill
- Komatsu Payload Weighing System—PLM-III
- Mirrors, LH flat and RH rectangular convex
- Mud flaps
- Muffled exhaust—deck-mounted
- Power supply, 24 volt and 12 volt DC
- Quick disconnects (hoist and diagnostics)
- Radiator sight gauge
- Removable power module unit (radiator, engine, alternator, blower)
- Retard speed control
- Reverse retarding
- Rock ejectors
- Thermostatic fan clutch
- Fast-fill fuel system (in tank and left side remote)
- Service center—LH
- Body impact plate

OPERATOR ENVIRONMENT & CONTROL

- All hydraulic service brakes with emergency auto apply
- Battery disconnect switch
- Body up sling
- Brake lock and drive system interlock
- Circuit breakers, 24 volt
- Diagonal staircase across grill, L to R
- Dynamic retarding with continuous rated element grids
- Engine shutdown at ground level
- Hoist propulsion interlock
- Horns (electric—front and back-up)
- Integral ROPS/FOPS cab Level 2
- Maintenance and power lockout
- Parking brakes with warning light & speed application protection

- Power steering w/auto emergency steering
- Protective deck handrails
- Pump driveline protector
- Radiator fan guard
- Seat belts 76 mm 3" wide retractable
- Slip-resistant coating on walkways

STANDARD HIGH VISIBILITY DELUXE CAB

- AC drive interface display
- Air cleaner vacuum gauges
- Air conditioner HFC-134A
- Alarm system warning lights (red)
 - Accumulator pre-charge
 - Auto lube pressure, low
 - Battery charge
 - Brake/hydraulic oil temp w/alarm
 - Electric system fault w/alarm
 - IM fail
 - Link energized
 - Low engine oil pressure w/alarm
 - Low brake pressure w/alarm
 - No propel/retard power w/alarm
 - Stop engine no propel w/alarm
 - Steering pressure w/alarm
- AM/FM radio/CD/mp3 and XM™ capable
- Column-mounted retarder control
- Digital tachometer and speedometer
- Dome light
- Engine hourmeter, oil pressure gauge, coolant temperature gauge, hydraulic oil temperature gauge
- Engine shutdown w/5 minute delay timer
- Floor mat (double barrier)
- Fuel gauge in cab and on tank
- Fuel low level light and buzzer
- Gauges (w/backlight)
- Headlight switch
- Heater and defroster (heavy-duty)
- Heater switch
- High beam selector and indicator
- Horn (center of steering wheel)
- Indicator lights (amber):
 - 5-minute shutdown timer
 - Check engine w/alarm
 - Circuit breaker tripped
 - Coolant high temperature w/alarm
 - Drive system temperature w/alarm
 - Dump body up
 - Dynamic retarding

- Low fuel
- Manual back-up lights
- Parking brakes applied
- Propel system not ready
- Propulsion system caution
- Propulsion system at rest
- Reduced propel system mode
- Retard at continuous level
- Retard speed control
- Service brakes
- Starter circuit
- Indicator lights (blue)
 - Engine service
 - KOMTRAX Plus snapshot (IM)
- Insulation (Max R-Value)
- KOMTRAX Plus
- Operator seat, adjustable w/air suspension, lumbar support and arm rests
- Panel lighting (adjustable)
- Passenger seat, full size
- Payload Meter PLM III
- Power windows
- Pressurized cab air system w/fan on
- Single brake/retarder pedal
- Starter key switch
- Sunvisor (adjustable)
- Tilt & telescoping steering wheel
- Voltmeter (battery output)
- Windshield (tinted safety plate)
- Windshield wiper (dual) and washer (electric)

LIGHTING

- Back-up lights—rear mount (2) halogen
- Back-up lights—R and L - deck mount (2) halogen
- Brake and retard lights on top of cab
- Clearance lights
- Control cabinet service light (LED)
- Dynamic retarding, rear (2) halogen
- Engine compartment service lights
- Fog lights (2) halogen
- Headlights (8) halogen
- Stairway lights
- Manual back-up light, switch and indicator
- Payload lights R and L (LED)
- Platform lights R, L and Center
- Stop & tail lights (2) (LED)
- Turn signals halogen
- Under-hood service lights



OPTIONAL EQUIPMENT

Note: Optional equipment may change operating weight.

- Body liners*
- Fire extinguisher 9 kg **20 lb**
- Heated body
- Hot start engine coolant (220V 2-2500W)
- Hot start engine oil (220V 2-600W)
- Hubodometer (miles or Kilometers)
- Modular Mining Systems (MMS) ready
- Mufflers between frame rails
- Radiator shutters
- Reversed access ladder
- Service center—RH or dual LH/RH
- Special language decals
- Suspensions, cold weather

*Available factory installed or non-installed. All other options and accessories listed are available factory installed only.

AESS743-00

©2007 Komatsu America Corp.

Printed in USA

D2(1.5M)C

2/07 (EV-3)

KOMATSU®