

KOMATSU®

HD605-7

With Tier 3 Engine

GROSS HORSEPOWER

551 kW 739 HP

NET HORSEPOWER

533 kW 715 HP

MAXIMUM GVW

110180 kg 242,900 lb

**HD
605**

OFF-HIGHWAY TRUCK



Photo may include optional equipment

WALK-AROUND

Productivity Features

- 7-speed, fully automatic K-ATOMiCS transmission
- Automatic Idling Setting System (AISS)
- Automatic Retard Speed Control (ARSC)
- Fully hydraulic controlled wet multiple-disc brakes and retarder; Retarder absorbing capacity (Continuous descent) 785 kW **1,052 HP**
- High performance Komatsu SAA6D170E-5 engine
Net horsepower 533 kW **715 HP**
- Long wheelbase and wide tread
- Large high strength body
Heaped capacity 40.0 m³ **52.3 yd³**
- Mode selection system
(Variable horsepower at Economy mode)
- Small turning radius 8.5 m **27'11"**

Environment Friendly

- Brake cooling oil recovery tank
- Komatsu SAA6D170E-5 engine is North American EPA Tier 3 and EU Stage 3A emission certified
- Lead-free radiator
- Low operation noise

Reliability Features

- Antilock Brake System (ABS) (Option)
- Automatic Spin Regulator (ASR) (Option)
- Box section frames
- Flat face-to-face O-ring seals
- Komatsu designed components
- Pedal-operated secondary brake
- Reliable hydraulic system
- Rugged and durable dump body design
- Sealed DT electrical connectors



Operator Environment

- Built-in ROPS/FOPS Level 2
- Easy-to-see instrument panel
- Electric body dump control lever
- Electric operated LH window
- Ergonomically designed cab
- Hydropneumatic suspension
- K-ATOMiCS with “Skip-Shift” function
- Supplementary steering and secondary brakes
- Tilttable, telescoping steering wheel and low effort pedals
- Viscous cab mounts
- Wide, spacious cab with excellent visibility

GROSS HORSEPOWER
551 kW 739 HP @ 2000 rpm

NET HORSEPOWER
533 kW 715 HP @ 2000 rpm

MAXIMUM GVW
110180 kg 242,900 lb

***Easy Maintenance***

- Advanced monitoring system-onboard diagnostics
- Centralized arrangement of filters
- Centralized greasing points
- Electric circuit breaker
- Extended oil change interval
- Flange type tire rims
- KOMTRAX Plus with Payload Meter and ORBCOMM (Standard)
- Wet multiple-disc brakes and fully hydraulic braking system

Photo may include optional equipment

PRODUCTIVITY FEATURES

Komatsu Technology



Komatsu's new "ecot3" engines are designed to deliver optimum performance under the toughest of conditions while meeting the latest environmental regulations. This engine is Tier 3 EPA, EU Stage 3A and Japan emissions certified. "ecot3" – ecology and economy combined with Komatsu technology to create a high performance engine without sacrificing power or productivity.

High performance Komatsu SAA6D170E-5 engine

This engine delivers faster acceleration and higher travel speeds with high horsepower per ton. Advanced technology, such as Common Rail Injection system (CRI), air-to-air aftercooler, efficient turbo-charger, and heavy-duty cooled EGR enables the engine to be North American EPA Tier 3 and EU stage 3A emission certified. High torque at low speed, impressive acceleration, and low fuel consumption ensure maximum productivity.

Mode selection system

The system allows selection of the appropriate mode between <Power mode > or <Economy mode> according to each working condition. The mode is easily selected with a switch in the operator's cab.

Power mode

Greater productivity can be attained by taking full advantage of high output power. This mode is appropriate for job sites where high production and uphill-hauling are required.

Economy mode (variable horsepower)

The engine power automatically changes depending on loaded or unloaded conditions and always uses an optimum gear speed. It is appropriate for lighter load factors on flat ground.

Automatic Idling Setting System (AISS)

This system facilitates quick engine warm-up and cab cooling/warming. When setting the system ON, engine idle speed is kept at 945 rpm when coolant temperature is 50°C **122°F** or lower. Speed automatically returns to 725 rpm when coolant temperature reaches 50°C **122°F**.



7-speed, fully automatic K-ATOMiCS transmission

The K-ATOMiCS (Komatsu Advanced Transmission with Optimum Modulation Control System) automatically selects the optimum gear according to vehicle speed, engine speed and the shift position you've chosen. This results in the best gear for any operating condition.



K-ATOMiCS (Komatsu Advanced Transmission with Optimum Modulation Control System)

Automatic Retard Speed Control (ARSC)

ARSC allows the operator to simply set the downhill travel speed and go down slopes at a constant speed. As a result, the operator can concentrate on steering. The speed can be set at increments of 1 km/h **0.6 MPH** per click (± 5 km/h **3.1 MPH** of maximum speed adjustment) to match the optimum speed for the slope. Also, since the retarder cooling oil temperature is always monitored, the speed is automatically lowered if the retarder oil temperature rises.

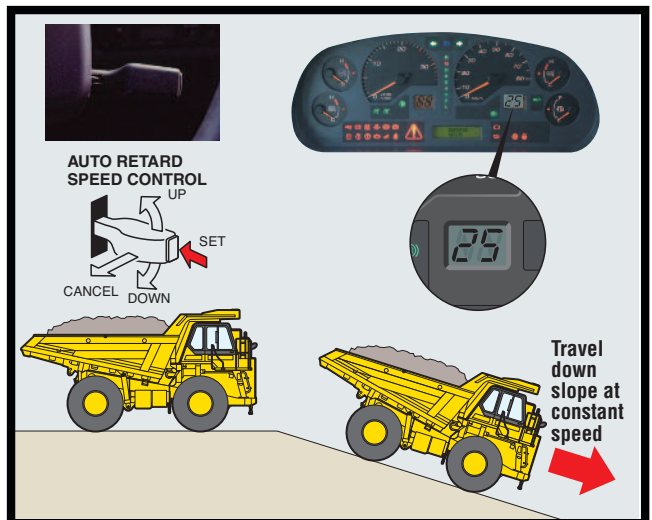

Fully hydraulic controlled wet multiple-disc brakes and retarder

Wet multiple-disc brakes ensure highly reliable and stable brake performance. The large-capacity, continuously cooled, wet multiple-disc brakes also function as a highly responsive retarder which gives the operator greater confidence at higher speeds when travelling downhill.

- Retarder Absorbing Capacity (continuous descent): 785 kW
- **1,052 HP**
- Brake Surface Area (rear): 64230 cm²
- **9,956 in²**

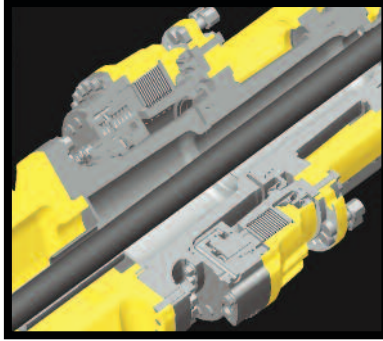

Long wheelbase and wide tread

With an extra-long wheelbase, a wide tread and an exceptionally low center of gravity, the HD605-7 hauls the load at higher speed for more production, and delivers superior driving comfort over rough terrain.

Large high strength body

A wide target area makes for easy loading with minimal soil spillage and more efficient hauling. The body is built of a high wear-resistant high-tensile steel. The V-shape design also increases structural strength and provides excellent load stability.

Small turning radius

The MacPherson strut type front suspension has a special A-frame between each wheel and the main frame. The wider space created between the front wheels and the main frame increases the turning angle of the wheels. The larger the wheel turning angle, the smaller the turning radius of the truck.

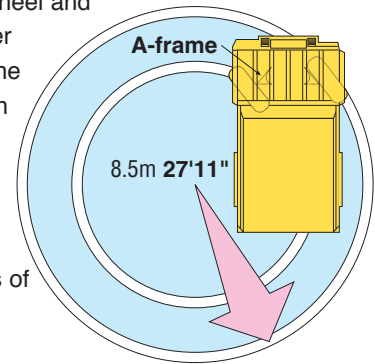

OPERATOR ENVIRONMENT

Wide, spacious cab with excellent visibility

Wide windows in the front, side and back, plus plenty of space in the richly upholstered interior, provide a quiet, comfortable environment from which to see and control every aspect of operation. Front and side under view mirrors have been added.

Ergonomically designed cab

The ergonomically designed operator's compartment makes it very easy and comfortable for the operator to use all the controls. The result is more confident operation and greater productivity.

Easy-to-see instrument panel

The instrument panel makes it easy to monitor critical machine functions. In addition, a caution light warns the operator of any problems that may occur. Problems are recorded in the monitor and indicated as service codes. These onboard diagnostics make the machine user friendly and easy to service.

Optimum operator seat position

The 5-way adjustable operator seat and the tilt-telescopic steering column create an optimum operating posture for increased operating comfort and more control over the machine's operations. The suspension seat dampens vibrations transmitted from the machine, which reduces operator fatigue and holds the operator securely to assure confident operation. 78 mm 3" width seat belt is provided as standard equipment.



Hydropneumatic suspension for all terrain

The hydropneumatic suspension assures a comfortable ride even over rough terrain and ensures maximum productivity and operator confidence.

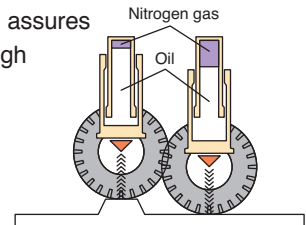

K-ATOMiCS with “Skip-shift” function

An electronically controlled valve is provided for each clutch pack in the transmission for independent clutch engagement/disengagement. It enables an ideal change in clutch modulation pressure and torque cut-off timing in response to travel conditions. This system plus the “skip-shift” function ensure smooth shifting and responsive acceleration.

“Skip-shift” function

Optimum travel speed is automatically selected in response to the angle of ascent. Reduced frequency of downshift and smoother operation improves operator comfort and truck reliability.

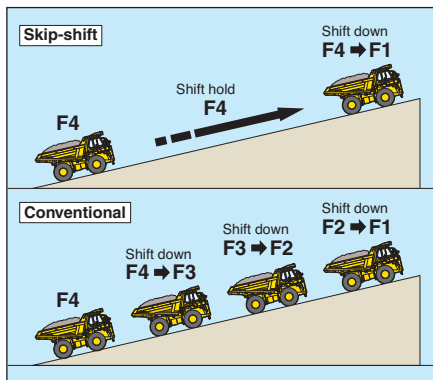

Built-in ROPS/FOPS Level 2

These structures conform to ISO3471 and SAE J1040 ROPS standards, and ISO 3449 and SAE J231 FOPS Level 2 standards.



Viscous cab mounts

Viscous mounts reduce the noise transmitted to the cab and achieve a quiet 77 dB(A) noise level.

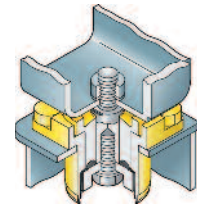

Electric body dump control lever

The low effort lever makes dumping easy. A positioning sensor is installed for dump body control which significantly reduces the shock made by the lowering of the dump body.



Supplementary steering and secondary brakes

Supplementary steering and secondary brakes are standard features.

Steering: ISO 5010, SAE J1511, SAE J53

Brakes: ISO 3450, SAE J1473



RELIABILITY FEATURES

Komatsu components

Komatsu manufactures the engine, torque converter, transmission, hydraulic units, and electrical parts on this dump truck. Komatsu dump trucks are manufactured with an integrated production system under a strict quality control system.

High-rigidity frame

Cast-steel components are used in the main frame for high-stress areas where loads and shocks are most concentrated.

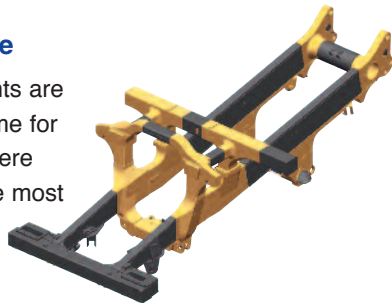

Rugged and durable dump body design

The standard dump body is made of a high-tensile-strength steel for excellent rigidity and reduced maintenance cost.

The V-shape design also increases structural strength. The side and bottom plates of the dump section are reinforced with ribs for added strength.



Reliable hydraulic system

The oil cooler is installed in the radiator lower tank, improving the reliability of the hydraulic system during sudden temperature rises. In addition to the main filter, a 25-micron line filter is installed at the entrance to the transmission control valve. This system helps to extend the valve and transmission life.

Flat face-to-face O-ring seals

Flat face-to-face O-ring seals are used to securely seal all hydraulic hose connections to prevent oil leakage.

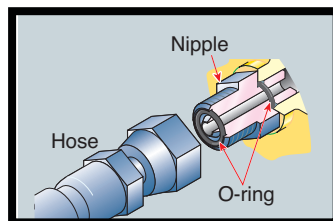

Sealed DT electrical connectors

Main harnesses and controller connectors are equipped with sealed DT connectors providing high reliability, water resistance, and dust resistance.

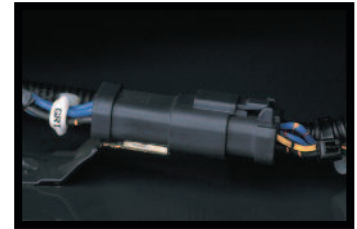

Antilock Braking System (ABS) (Option)

Using its outstanding electronics technology, Komatsu is the first in the industry to introduce ABS on construction machinery. This system prevents the tires from locking, thus minimizing skidding under slippery conditions while applying the service brake.

Automatic Spin Regulator (ASR) (Option)

ASR automatically prevents the rear tires, on either side, from slipping on soft ground for optimal traction.

Pedal-operated secondary brake

If there should be a failure in the foot brake, the parking brake and front disc brakes are activated as pedal operated secondary brake. In addition, when hydraulic pressure drops below the rated level, the parking brake is automatically actuated.



Lead-free radiator

In addition to compliance with emission regulations, a lead-free aluminum core is utilized for the radiator to comply with global environmental requirements.

Brake cooling oil recovery tank

To protect the environment, a tank is installed to recover brake cooling oil in the event of brake seal leakage.

Protection functions supported by electronic control

Item	Function
Downshift inhibitor	Even if the driver downshifts accidentally, a speed appropriate to the current gear is automatically set, preventing over-runs.
Over-run inhibitor	When descending grades, if vehicle's speed surpasses maximum for current gear, rear brakes automatically operate, preventing over-runs.
Reverse inhibitor	The vehicle is prevented from moving backward when operating the body.
Forward/Reverse shift inhibitor	This device makes it impossible to shift from forward to reverse when the vehicle's speed surpasses 4 km/hr 2.5 mph .
Anti-hunting system	When running near a shift point, a smooth automatic shifting takes place.
Neutral engine start system	The engine is prevented from starting when the shift lever is not in neutral.

EASY MAINTENANCE

Advanced monitoring system

The Komatsu advanced onboard diagnostic system identifies maintenance items, reduces diagnostic times, indicates oil and filter replacement hours and displays abnormality codes. This monitor system helps to maximize machine production time.



Wet multi-disc brakes and fully hydraulic braking systems

mean lower maintenance costs and higher reliability. Wet disc brakes are fully sealed to keep contaminants out, reducing wear and maintenance. The brakes require no adjustments for wear, resulting in lower maintenance. Added reliability is designed in the braking system with three independent hydraulic circuits providing hydraulic backup should one of the circuits fail. Fully hydraulic braking systems eliminate the air system so air bleeding is not required and water condensation, that can lead to contamination, corrosion and freezing, is also eliminated.

Extended oil change intervals

In order to minimize operating costs, oil change intervals have been extended:

- Engine oil: 500 hours
- Hydraulic oil: 4000 hours

Centralized arrangement of filters

The filters are centralized so that they can be serviced easily.

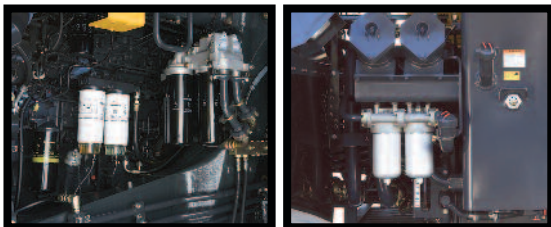

Flange type rim



Flange type rims provide easy removal/installation of tires.

Electric circuit breaker

A circuit breaker is used in important electric circuits that need to be restored quickly when a problem occurs in the electrical system.



Centralized greasing points

Greasing points are centralized at three locations.



KOMTRAX Plus

As part of a complete service and support program, Komatsu equips every mining and quarry sized machine with KOMTRAX Plus. By using a satellite-based communication system, KOMTRAX Plus offers a new vision of monitoring your valuable assets by providing insight to critical operating metrics and information that can be used to increase availability, lower owning and operating costs and maximize fuel efficiency.

The KOMTRAX Plus information available on MyKomatsu.com allows service personnel and asset owners to review cautions, operational data, fuel consumption, payloads and key component measurements provided in forms of trends. With KOMTRAX Plus, knowledge becomes the power to fuel your productivity.



Payload Meter (PLM)

PLM allows the production volume and the working conditions on the dump truck to be analyzed and controlled directly via a personal computer. The payload is indicated both in the operator's cab and with a lamp on the outside of the truck. The system can store up to 2900 working cycles.

SPECIFICATIONS



ENGINE

Model Komatsu SAA6D170E-5
 Type Water-cooled, 4-cycle
 Aspiration Turbo-charged, air-to-air after-cooled, cooled EGR
 Number of cylinders 6
 Bore x stroke 170 mm x 170 mm **6.69" x 6.69"**
 Piston displacement 23.15 ltr **1,413 in³**
 Horsepower: SAE J1995 Gross 551 kW **739 HP**
 ISO9249/SAE J1349 Net 533 kW **715 HP**
 Rated rpm 2,000 rpm
 Fan drive type Mechanical
 Maximum torque 339 kg·m **2,452 lb. ft**
 Fuel system Direct injection
 Governor Electronically controlled
 Lubrication system: Method Gear pump, force-lubrication
 Filter Full-flow type
 Air cleaner Dry type with double elements and
 precleaner (cyclonpack type), plus dust indicator
 EPA Tier 3 and EU Stage 3A emission certified.



TRANSMISSION

Torque converter 3-elements, 1-stage, 2-phase
 Transmission Full-automatic, planetary type
 Speed range 7 speeds forward and 1 reverse
 Lockup clutch Wet, multiple-disc clutch
 Forward Torque converter drive in 1st gear,
 direct drive in 1st lockup and all higher gears
 Reverse Torque converter drive
 Shift control Electronic shift control with automatic
 clutch modulation in all gears
 Maximum travel speed 70.0 km/h **43.5 mph**



AXLES

Rear Axle Full-floating
 Final drive type Planetary gear
 Ratios:
 Differential 3.538
 Planetary 4.737



SUSPENSION SYSTEM

Independent, hydropneumatic suspension cylinder with fixed throttle to dampen vibration
 Effective cylinder stroke (front suspension) 303 mm **11.9"**
 Rear axle oscillation:
 Oil stopper 6.8°
 Mechanical stopper 7.7°



STEERING SYSTEM

Type Fully hydraulic power steering
 with two double-acting cylinders
 Supplementary steering Manually controlled
 (meets ISO 5010, SAE J1511 and SAE J53)
 Minimum turning radius 8.5 m **27'11"**
 Maximum steering angle 39°



CAB

Dimensions comply with ISO 3471 and SAE J1040-1988c ROPS (Roll-Over Protective Structure) standards.



MAIN FRAME

Type Box-sectioned structure



BRAKES

Brakes meet ISO 3450 and SAE 1473 standards.
 Service brakes:
 Front Full-hydraulic control, caliper disc type
 Rear Full-hydraulic control, oil-cooled multiple-disc type
 Parking brake Spring applied, multiple-disc type
 Retarder Oil-cooled, multiple-disc rear brakes act as retarder
 Secondary brake Manual pedal operation
 When hydraulic pressure drops below the rated level,
 parking brake is automatically actuated
 Brake surface
 Front 1936 cm² **300 in²**
 Rear 64230 cm² **9,956 in²**



BODY

Capacity:
 Struck 29.0 m³ **37.9 yd³**
 Heaped (2:1, SAE) 40.0 m³ **52.3 yd³**
 Payload 63.0 metric tons **69.4 U.S. tons**
 Material 160 kg/mm² **227,520 psi**
 high tensile strength steel
 Structure V-shape body with V-bottom
 Material thickness:
 Bottom 25 mm **0.98"**
 Front 16 mm **0.63"**
 Sides 14 mm **0.55"**
 Target area
 (inside length x width) 6600 mm x 3870 mm **21'8" x 12'8"**
 Dumping angle 48°
 Height at full dump 8800 mm **28'10"**
 Heating Exhaust heating



HYDRAULIC SYSTEM

Hoist cylinder Twin, 2-stage telescopic type
 Relief pressure 20.6 MPa 210 kg/cm² **2,990 psi**
 Hoist time 11.5 sec



WEIGHT (APPROXIMATE)

Empty weight 46200 kg **101,850 lb**
Max. gross vehicle weight:
 Standard tire 110180 kg **242,900 lb**
 Not to exceed max. gross vehicle weight, including options, fuel
 and payload
Weight distribution:
 Empty: Front axle 47%
 Rear axle 53%
 Loaded: Front axle 32%
 Rear axle 68%



TIRES

Standard tire 24.00 R35



SERVICE REFILL CAPACITIES

Fuel tank 780 ltr. **206.1 U.S. Gal**
 Engine oil 80 ltr. **21.1 U.S. Gal**
 Torque converter, transmission and
 retarder cooling 215 ltr. **56.8 U.S. Gal**
 Differential 95 ltr. **25.1 U.S. Gal**
 Final drives (total) 42 ltr. **11.1 U.S. Gal**
 Hydraulic system 122 ltr. **32.2 U.S. Gal**
 Suspension (total) 55.6 ltr. **14.7 U.S. Gal**



DIMENSIONS

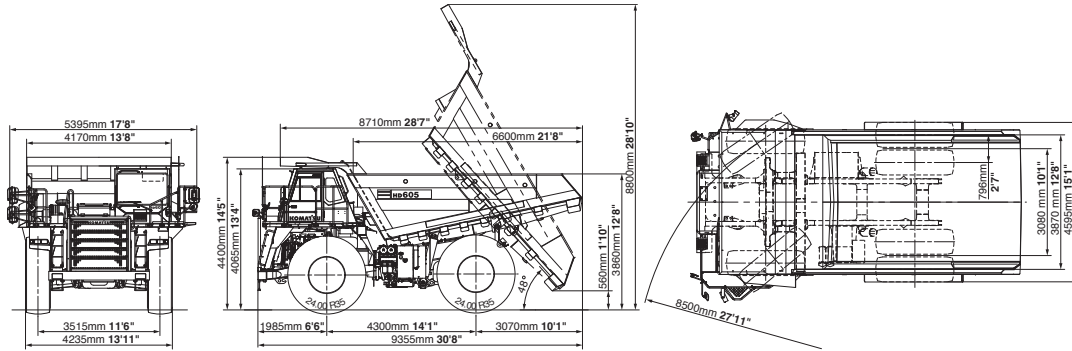

TRAVEL PERFORMANCE

To determine travel performance:
 Read from gross weight down to the percent of total resistance. From this weight-resistance point, read horizontally to the curve with the highest obtainable speed range, then down to maximum speed. Usable rimpull depends upon traction available and weight on drive wheels.

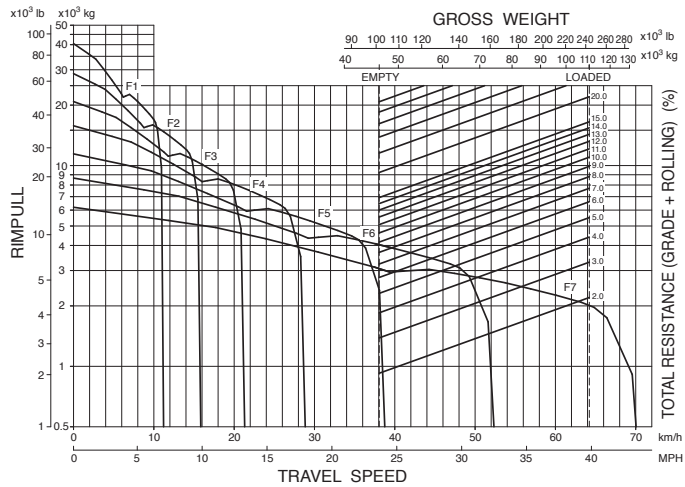

BRAKE PERFORMANCE

To determine brake performance:
 These curves are provided to establish the maximum speed and gearshift position for descents on roads with a given distance. Read from gross weight down to the percent of total resistance. From this weight-resistance point, read horizontally to the curve with the highest obtainable speed range, then down to maximum descent speed the brakes can handle without exceeding cooling capacity.

Grade distance: Continuous descent

Grade distance: 450 m (1480 ft)

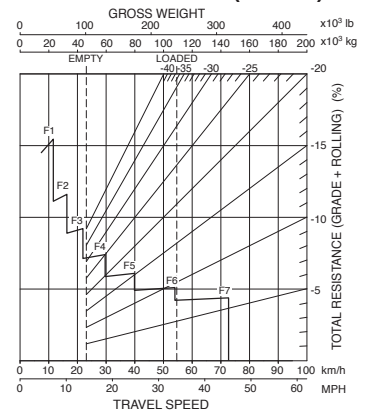
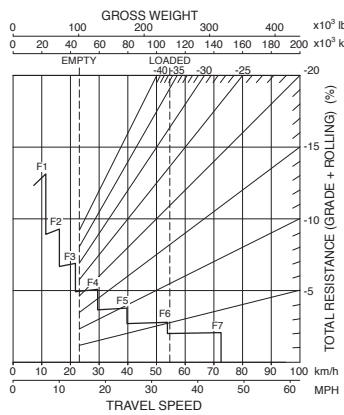

Grade distance: 600 m (1970 ft)

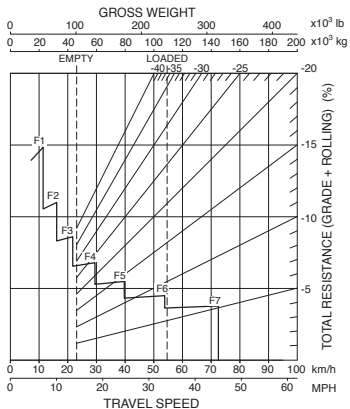

Grade distance: 900 m (2950 ft)

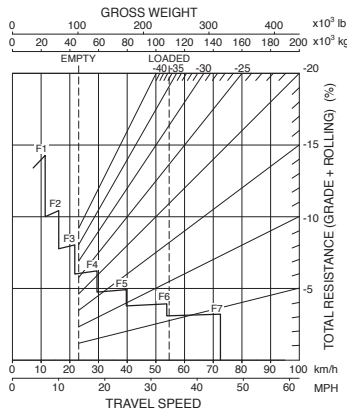

Grade distance: 1500 m (4920 ft)

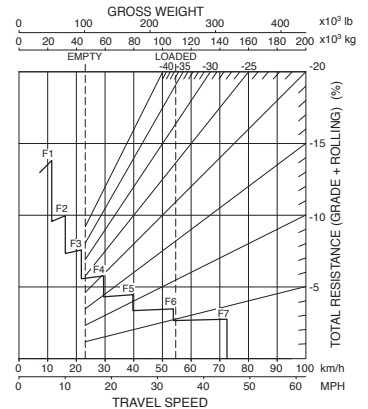



STANDARD EQUIPMENT

ENGINE:

- Automatic Idling Setting System (AISS)
- Alternator, 75A/24V
- Batteries, 2 x 12V/200Ah
- Engine, Komatsu SAA6D170E-5
- Starting motor, 2 x 7.5 kW
- Variable horsepower system

CAB:

- 12 Volt outlet port
- Air conditioner/heater/defroster/ electronically controlled
- Ashtray
- Cigarette lighter
- Cup holder
- Electronic hoist control system
- Electronic maintenance display/monitoring system
- Operator seat, reclining, suspension type with retractable 78 mm 3" width seat belt
- Passenger seat with retractable 78 mm 3" width seat belt

- Power window (L.H.)
- ROPS cab with FOPS Level 2, sound suppression type
- Radio, AM/FM with cassette
- Space for lunch box
- Steering wheel, tilt and telescopic
- Sunvisor
- Tinted glass
- Two doors, left and right
- Windshield washer and wiper (with intermittent feature)

LIGHTING SYSTEM:

- Back-up light
- Hazard lights
- Headlights with dimmer switch
- Indicator, stop and tail lights

GUARD AND COVERS:

- Drive shaft guard (front and rear)
- Engine and transmission underguards
- Exhaust thermal guard
- Fire protective covers

BODY:

- Body exhaust heating
- Cab guard, left side
- Spill guard, 150 mm 6"

OTHER:

- Alarm, backup
- Automatic Retard Speed Control (ARSC)
- Centralized greasing
- Coolant temperature alarm and light
- Electric circuit breaker, 24V
- Front brake cut-off system
- Hand rails for platform
- Horn, electric
- KOMTRAX Plus with PLM and ORBCOMM
- Ladders, left and right hand side
- Mud guards
- Overrun warning system
- PLM payload meter
- Rearview mirrors
- Supplementary steering, automatic
- Under view mirrors



OPTIONAL EQUIPMENT

CAB:

- Seat, air suspension

BODY:

- Body liner
- Deck mounted muffler, no body heat
- Deck mounted muffler, with body heat

LIGHTING SYSTEM:

- Back work lights, RH and LH side
- Fog lights

TIRES:

- 24.00 R35

OTHERS:

- Automatic Spin Regulator (ASR)
- Antilock Brake System (ABS)
- Fast fill fuel system

Standard equipment may vary for each country. This specification sheet may contain attachments and optional equipment that are not available in your area. Please consult your Komatsu distributor for detailed information.

KOMATSU®

