

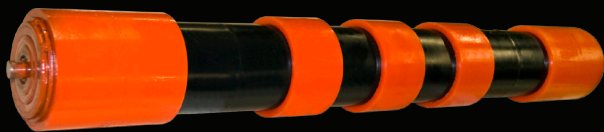

**MINING AGGREGATES COAL AGRICULTURE WOOD**



**POWER**

**RECYCLE**

**SALT**

**SULPHUR**

**CEMENT**

# **IDLER CATALOG**

# SpinGuard® Seal System Cutaway

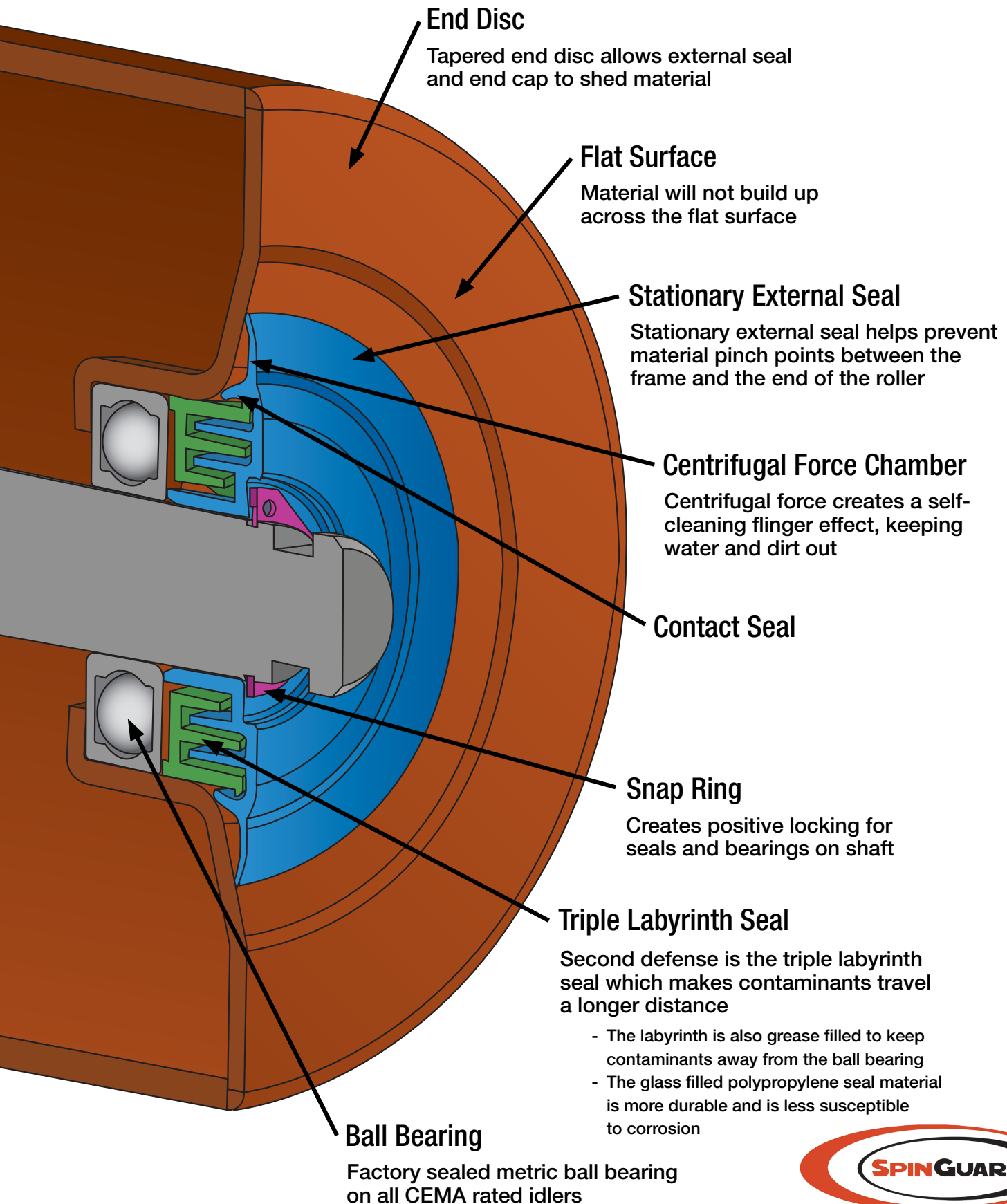

# Table of Contents

## Superior Idlers

2	Styles	35	Return Idlers – Self-Aligning
3	Ordering Guide	35	Feeder / Picking Idlers
4	Roll Interchange	36	Troughing Idlers – Unequal Length Rollers
	<b>CEMA B</b>		<b>CEMA E</b>
5	Troughing Idlers – Equal Length Rollers	37	Troughing Idlers – Equal Length Rollers
6	Troughing Idlers – Rubber Cushion Impact	37	Troughing Idlers – Rubber Cushion Impact
6	Urathon® Return Roll	38	Return Idlers – Rubber Cushion
7	Return Idlers	39	Troughing Idler – Self-Aligning
7	Flat Idlers	40	Return Idlers
7	Return Idlers – Rubber Cushion	40	Flat Idlers – Rubber Cushion
7	Flat Idlers – Rubber Cushion	40	Flat Idlers
8	Troughing Idlers – Self-Aligning	40	Return Idlers – Self-Aligning
8	Return Idlers – Self-Aligning	41	Urathon® Return Rolls
9	Offset Center Roll Idlers	41	V-Return Idlers
10	Channel Mount Idlers		<b>CEMA F</b>
10	Channel Mount Impact Idlers	42	Troughing Idlers – Equal Length Rollers
	<b>CEMA C</b>		<b>OTHER STYLES</b>
11	Troughing Idlers – Equal Length Rollers	43	Component Parts & Replacement Rolls
14	Return Idlers	43	CEMA B & C Replacement Rolls
14	Flat Idlers	44	CEMA D & E Replacement Rolls
14	Garland Idlers	45	81 Series CEMA C Regreaseable Idlers
15	Troughing Idlers – Rubber Cushion Impact	58	91 Series CEMA D Regreaseable Idlers
18	Return Idlers – Rubber Cushion	64	Regreaseable Idler Parts
18	Flat Idlers – Rubber Cushion	65	40 Series
18	V-Return Idlers	66	CB504 Series
19	Urathon® Return Rolls	66	Component Accessories
19	Troughing Idlers – Self-Aligning	67	Navigator® Training Idlers
21	Return Idlers – Self-Aligning	67	Return Guides
22	Troughing Idlers – Feeder / Picking	68	80/81 & 90/91 Hex Style Roll Guard
23	Troughing Idlers – Unequal Length Rolls	68	Slotted Shaft Return Guard
25	Offset Center Roll Idlers	68	Beater Bar Return Roll
27	Channel Mount Idlers	69	Live Shaft Rollers
28	Low Profile Standard Mount	69	Side Guide Idlers
29	Channel Mount Impact Idlers	69	Vertical Side Guide Roll
	<b>CEMA D</b>	69	Urethane Vertical Side Guide Roll
30	Troughing Idlers – Equal Length Rolls	69	Stub Roll Idlers
31	Return Idlers	70	Variable Pitch Idlers
31	Flat Idlers	70	Wire Rope Pitch
31	V-Return Idlers	71	Rubber Lagged Conveyor Rollers
32	Troughing Idlers – Rubber Cushion Impact	72	Sealing System
33	Return Idlers – Rubber Cushion	73	Impact Beds
33	Flat Idlers – Rubber Cushion	74	Return & Flat Bracket Styles
33	Urathon® Return Rolls	76	Specialized Designs
34	Troughing Idlers – Self-Aligning	77	Idler Selection Procedure
		81	Terms & Conditions

# Basic Idler Styles

Styles

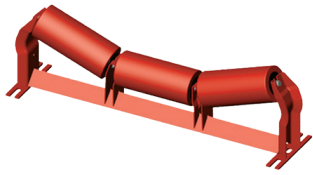

Equal troughing idlers

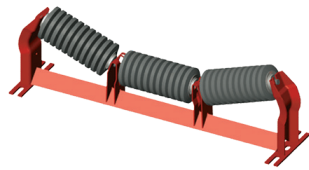

Impact idlers

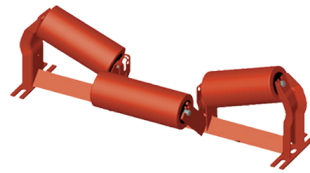

Offset center roll idlers

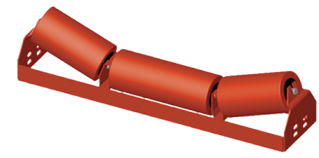

Channel mount low profile idlers

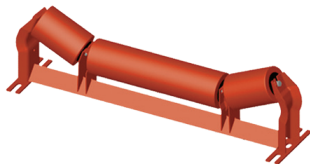

Feeder/picking idlers

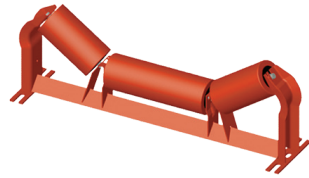

Unequal troughing idlers

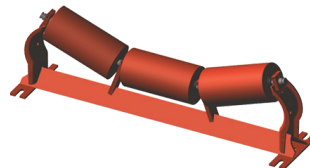

CB504 Series idlers

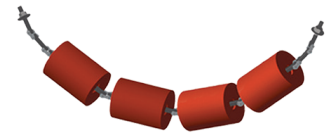

Garland idlers

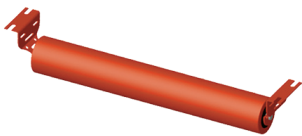

Return belt idlers



Rubber cushion return idlers



Urathon® return roll

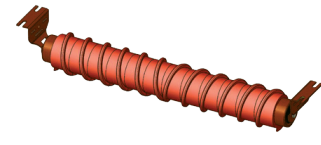

Spiral Urathon return roll

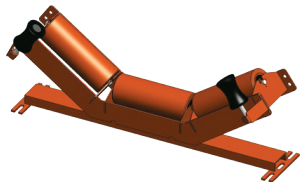

Self-Aligner idlers



Self-Aligner returns

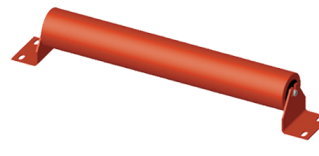

Flat carrier idlers

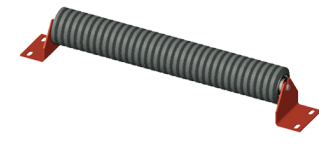

Rubber cushion flat carries



Live shaft rollers

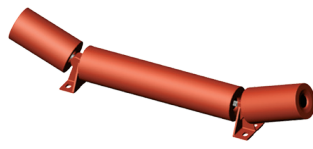

40 Series idlers

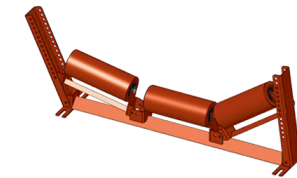

Variable pitch idlers

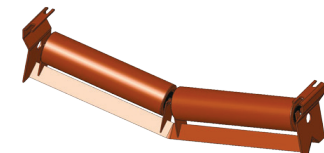

V-Return idlers

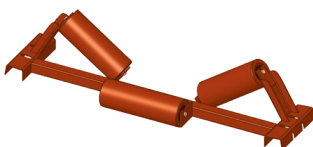

Wire rope idlers

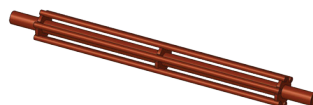

Beater Bar

# Ordering Guide

## C5 - 35 E - 36

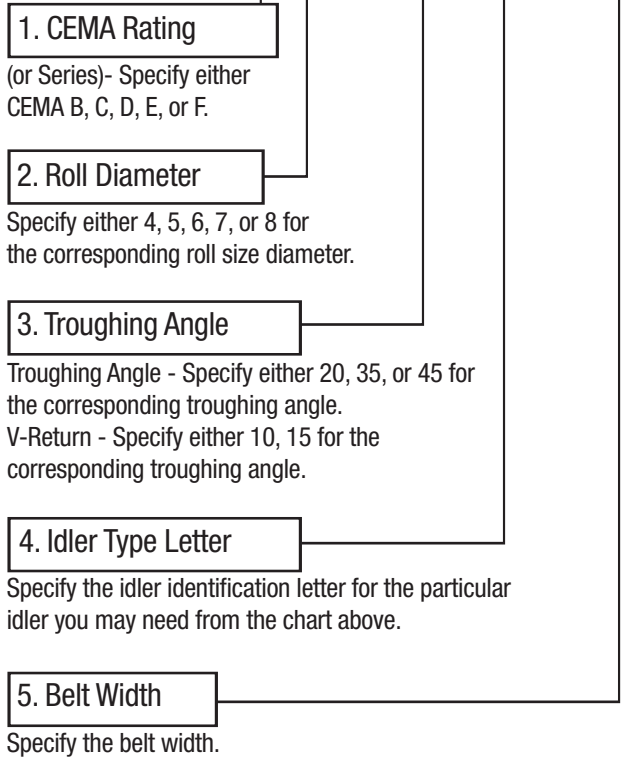

- E..... Troughing Idler Equal Length Rolls
- EA ..... Self-Aligning Troughing Idler
- BA ..... Bi-Directional Aligning Troughing Idler
- EI..... Rubber Cushion Troughing Idler
- GO ..... Offset Troughing Idler
- U ..... Troughing Idler Unequal Length Rolls
- P ..... Feeder / Picking Idler
- RET ..... Return Idler
- FLT ..... Flat Carrier Idler
- RETA ..... Return Self-Aligning Idler
- RETI..... Return Rubber Cushion Idler
- FLTI ..... Flat Carrier Rubber Cushion Idler
- CM ..... Low-Profile Channel Mount Idler
- CMI ..... Channel Mount Impact Low Profile Idler
- SM ..... Low-Profile Standard Mount Idler
- SMI..... Standard Mount Impact Low Profile Idler
- RETAI..... Return Self-Aligning Rubber Lagged Cushion Idler
- EW ..... Wire Rope Idler
- VPE..... Variable Pitch Idler
- RETU ..... Urathon® Return
- RETUSP..... Spiral Urathon® Return
- MOX ..... Moxie® Roll (i.e. C5-35E-30MOX)
- LSB ..... Live Shaft Beater (i.e. LSB-530-107)

Superior makes ordering easy with a simple number and letter system so you can easily jot down the idlers you need and relay them to our sales staff. This will eliminate confusion and ensure accuracy on your order. Simply follow the procedure above and you'll be on your way to placing an accurate order. Superior manufactures many different styles of CEMA B, C, D, E, and F idlers along with a full line of CB-504 style bearing idlers and rollers. We have been in the idler manufacturing business since 1974 and have modified and expanding our product offering to provide solutions for our customers. We appreciate feedback from the field on ways to improve our products.

### Shipping Notes

- \* 4-6 Pulleys fit per pallet depending on size
- \* CB ROLLS: 2 returns per box or 6 rolls per box for UPS
- \* Expedite services are available for a minimum of \$50

### Pallet Loads for Shipping

#### Returns

Roller Diameter	Pieces/Pallet
4"	34 max
5"	21 max
6"	18 max

#### CEMA B Idlers

Roller Diameter	Idlers/Row	Number of Rows	Pieces/Pallet
4"	11	2 rows	22 max
5"	9	2 rows	18 max

#### Hex Brackets

Bracket	Weight
4-1/2" Drop	3 lb
1 1/2" Drop	2.05 lb
4-1/2" Rise	2.8 lb
1 1/2" Rise	1.25 lb

#### Other Products

Product	Pieces/Pallet
Picking Idlers	Standard
Channel Mounts	20 max
Self Aligners (EA)	2 max
Self Aligners (RETA)	3 max
Bi-Directional	3 max
Off Set Idlers (GO)	7 max

#### CEMA C Idlers

Roller Diameter	Idlers/Row	Number of Rows	Pieces/Pallet
4"	11	Up to 36" BW = 2 rows	22 max
		42" - 48" BW = 2 rows	22 max
5"	9	Up to 36" BW = 2 rows	18 max
		42" BW = 2 rows	18 max
		48" BW = 2 rows	18 max
		54" BW & up = 1 row	8 max
6"	7	Up to 30" BW = 2 rows	14 max
		36" BW & up = 1 row	7 max

#### Slotted Brackets

Bracket	Weight
4-1/2" Drop	1.54 lb
1 1/2" Drop	.84 lb
4-1/2" Rise	2.94 lb
1 1/2" Rise	1.76 lb

# Roll Interchange

## Competitor Retros

### Part Numbering

# C6-360100

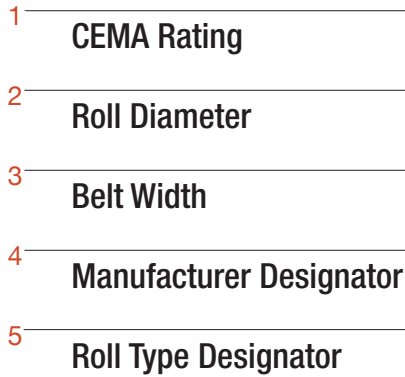

- 01: Precision
- 02: Continental (HC-slot)
- 03: Stephens Adamson
- 04: Manufacture
- 05: FMC (slot)
- 06: Hewitt-Robins (slot)
- 07: Luff
- 08: Assink
- 09: Strongco
- 10: Douglas (slot)
- 11: FMC 3000 (nut)
- 12: Douglas (nut)
- 13: Rexnord (nut)
- 14: Hewitt-Robins (nut)
- 15: Continental (H<sup>+</sup>-nut)
- 16: Goodman (nut)

1. **CEMA Rating or Series** - Specify either CEMA B, C, D, or E.
2. **Roll Size** - Specify either 4, 5, 6 or 7 for the corresponding roll size diameter.
3. **Belt Width** - Specify either 18, 24, 30, 36, 42, 48, 54, 60, 72, 84, or 96 depending on or CEMA rating.
4. **Manufacturer** - Specify the idler manufacturer that you are attempting to fit.
5. **Roll Type** - Specify the type of roll you are attempting to fit, steel trough (00), steel return (01), troughing impact (03), or return impact (11).

	Example	Roll 1
Shaft Type (slot/nut)	Slot	
Roll Diameter (RD)	5	
Roll Length (RL)	11.0625	
Frame Fit (FF)	11.30	
Slot-to-Slot (BB)	11.85	
Across Slot (AB)	.545	
Shaft Diameter (SD)	20mm	
Shaft Length (SL)	12.3125	
Through Shaft Diameter (TS)	20mm	
Hex Nut Outside-to-Outside (00)	-	

### Retro Fit Roll Dimensions

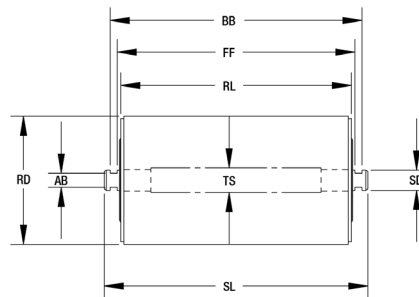

Slot or Hex Nut Dimensions	Example	Roll 1
A	20mm	
B	.545	
C	.231	
D	.275	
E	-	

### Slotted Shaft End

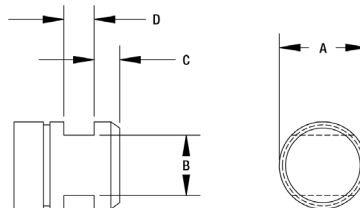

Style Slotted

### Roller

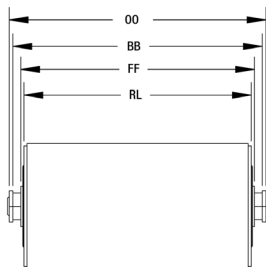

### Hex Nut End

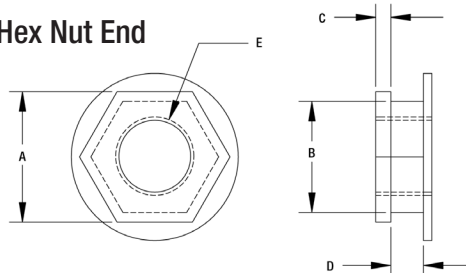

Style Hex Nut

# CEMA B Idlers

## Troughing Idlers (Equal Length Rollers) – 4" & 5" Diameter

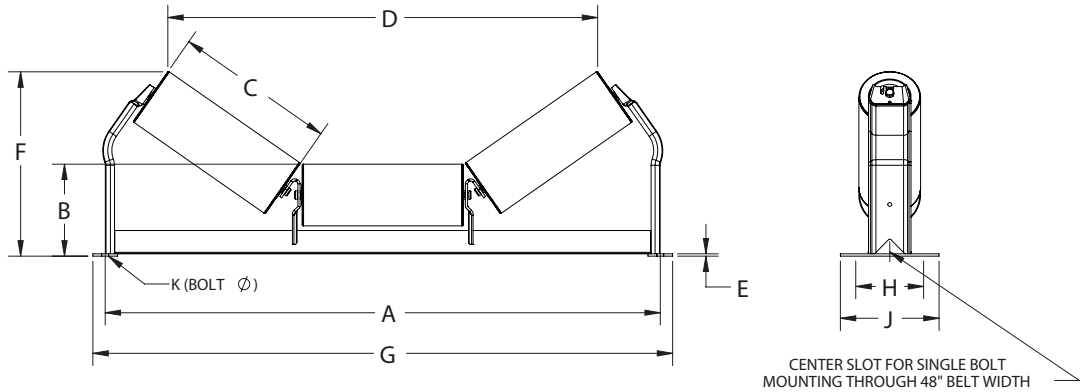

CEMA B

	PART NUMBER*		BW	A	B		C	D		E	F		G	H**	J	K	WT (#)	
	4"	5"			4"	5"		4"	5"		4"	5"					4"	5"
20°	B4-20E-14	B5-20E-14	14	23	6-15/16	7-7/16	6-1/16	18-15/16	18-9/16	3/16	9-1/8	9-9/16	25	6	8	1/2	25	30
	B4-20E-16	B5-20E-16	16	25	6-15/16	7-7/16	6-1/16	18-15/16	18-9/16	3/16	9-1/8	9-5/8	27	6	8	1/2	25	30
	B4-20E-18	B5-20E-18	18	27	6-15/16	7-7/16	7-1/16	21-3/4	21-7/16	3/16	9-7/16	9-7/8	29	6	8	1/2	27	33
	B4-20E-20	B5-20E-20	20	29	6-15/16	7-7/16	7-11/16	23-13/16	23-1/2	3/16	9-7/16	9-15/16	31	6	8	1/2	29	35
	B4-20E-24	B5-20E-24	24	33	6-15/16	7-7/16	9-1/16	27-1/2	27-3/16	3/16	10-1/8	10-9/16	35	6	8	1/2	32	39
	B4-20E-30	B5-20E-30	30	39	6-15/16	7-7/16	11-1/16	33-5/16	32-15/16	3/16	10-13/16	11-5/16	41	6	8	1/2	40	49
	B4-20E-36	B5-20E-36	36	45	6-15/16	7-7/16	13-1/16	39-1/16	38-11/16	3/16	11-1/2	12	47	6	8	1/2	46	56
	B4-20E-42	B5-20E-42	42	51	7-7/16	7-15/16	15-1/16	44-13/16	44-7/16	5/16	12-11/16	13-3/16	53	7-1/2	9-1/2	5/8	61	72
	B4-20E-48	B5-20E-48	48	57	7-7/16	7-15/16	17-1/16	50-9/16	50-3/16	5/16	13-3/8	13-7/8	59	7-1/2	9-1/2	5/8	67	80
35°	B4-35E-14	B5-35E-14	14	23	6-15/16	7-7/16	6-1/16	16-15/16	16-3/8	3/16	10-1/2	10-7/8	25	6	8	1/2	26	31
	B4-35E-16	B5-35E-16	16	25	6-15/16	7-7/16	6-1/16	16-15/16	16-3/8	3/16	10-1/2	10-7/8	27	6	8	1/2	26	31
	B4-35E-18	B5-35E-18	18	27	6-15/16	7-7/16	7-1/16	19-5/8	19	3/16	11-1/16	11-7/16	29	6	8	1/2	28	34
	B4-35E-20	B5-35E-20	20	29	6-15/16	7-7/16	7-11/16	21-13/16	21-5/16	3/16	11-1/8	11-9/16	31	6	8	1/2	30	36
	B4-35E-24	B5-35E-24	24	33	6-15/16	7-7/16	9-1/16	24-7/8	24-5/16	3/16	12-3/16	12-5/8	35	6	8	1/2	33	41
	B4-35E-30	B5-35E-30	30	39	6-15/16	7-7/16	11-1/16	30-3/16	29-9/16	3/16	13-3/8	13-13/16	41	6	8	1/2	42	50
	B4-35E-36	B5-35E-36	36	45	6-15/16	7-7/16	13-1/16	35-7/16	34-7/8	3/16	16-9/16	14-15/16	47	6	8	1/2	47	57
	B4-35E-42	B5-35E-42	42	51	7-7/16	7-15/16	15-1/16	40-11/16	40-1/8	5/16	16-3/16	16-9/16	53	7-1/2	9-1/2	5/8	62	74
	B4-35E-48	B5-35E-48	48	57	7-7/16	7-15/16	17-1/16	46	45-3/8	5/16	17-5/16	17-3/4	59	7-1/2	9-1/2	5/8	69	82
45°	<del>B4-45E-18</del>	<del>B5-45E-18</del>	<del>18</del>	<del>27</del>	<del>6-15/16</del>	<del>7-7/16</del>	<del>7-1/16</del>	<del>19-5/8</del>	<del>19</del>	<del>3/16</del>	<del>11-1/8</del>	<del>11-7/16</del>	<del>29</del>	<del>6</del>	<del>8</del>	<del>1/2</del>	<del>28</del>	<del>34</del>
	B4-45E-24	B5-45E-24	24	33	6-15/16	7-7/16	9-1/16	23	22-1/4	3/16	13-5/16	13-5/8	35	6	8	1/2	34	41
	B4-45E-30	B5-45E-30	30	39	6-15/16	7-7/16	11-1/16	27-13/16	27-1/8	3/16	14-3/4	15-1/8	41	6	8	1/2	42	51
	B4-45E-36	B5-45E-36	36	45	6-15/16	7-7/16	13-1/16	32-5/8	31-15/16	3/16	16-3/16	16-1/2	47	6	8	1/2	48	58
	B4-45E-42	B5-45E-42	42	51	7-7/16	7-15/16	15-1/16	37-1/2	36-3/4	5/16	18-1/8	18-7/16	53	7-1/2	9-1/2	5/8	63	75
	B4-45E-48	B5-45E-48	48	57	7-7/16	7-15/16	17-1/16	42-5/16	41-9/16	5/16	19-1/2	19-7/8	59	7-1/2	9-1/2	5/8	70	83

\*Add MOX to the end of the part number to replace steel cans with Moxie Rolls  
 \*\*Recommended Bolt Pattern - See page 75 for minimum and maximum dimensions.

# CEMA B Idlers

## Rubber Cushion Impact Troughing Idlers – 4” & 5” Diameter

CEMA B

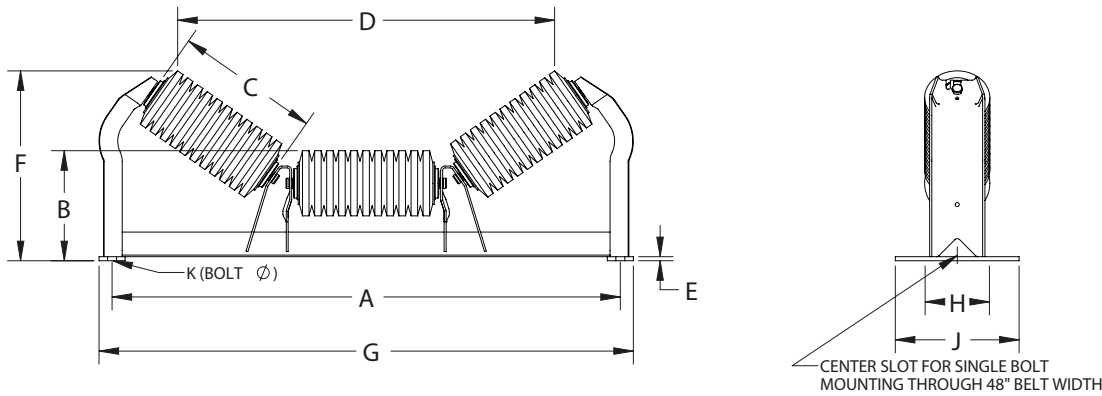

	PART NUMBER		BW*	B		C	D		E	F		G	H**	J	K	WT (#)		
	4"	5"		4"	5"		4"	5"		4"	5"					4"	5"	4"
20°	B4-20EI-18	B5-20EI-18	18	27	6-15/16	7-7/16	7-1/8	20-1/2	20-3/16	3/16	9-1/4	9-3/4	29	6	8	1/2	31	36
	B4-20EI-24	B5-20EI-24	24	33	6-15/16	7-7/16	9-1/8	26-1/4	25-15/16	3/16	9-15/16	10-3/8	35	6	8	1/2	38	43
	B4-20EI-30	B5-20EI-30	30	39	6-15/16	7-7/16	11-1/8	32	31-3/4	3/16	10-5/8	11-1/8	41	6	8	1/2	47	54
	B4-20EI-36	B5-20EI-36	36	45	6-15/16	7-7/16	13-1/8	37-3/4	37-1/2	3/16	11-5/16	11-13/16	47	6	8	1/2	63	72
	B4-20EI-42	B5-20EI-42	42	51	7-7/16	7-15/16	15-1/8	43-9/16	43-1/4	5/16	12-1/2	13	53	7-1/2	9-1/2	1/2	80	90
	B4-20EI-48	B5-20EI-48	48	57	7-7/16	7-15/16	17-1/8	49-5/16	49	5/16	13-3/16	13-11/16	59	7-1/2	9-1/2	5/8	88	99
35°	B4-35EI-18	B5-35EI-18	18	27	6-15/16	7-7/16	7-1/8	18-7/16	17-15/16	3/16	10-3/4	11-3/16	29	6	8	1/2	32	36
	B4-35EI-24	B5-35EI-24	24	33	6-15/16	7-7/16	9-1/8	23-11/16	23-3/16	3/16	11-7/8	12-5/16	35	6	8	1/2	39	44
	B4-35EI-30	B5-35EI-30	30	39	6-15/16	7-7/16	11-1/8	29	28-7/16	3/16	13-1/16	13-1/2	41	6	8	1/2	48	55
	B4-35EI-36	B5-35EI-36	36	45	6-15/16	7-7/16	13-1/8	34-3/16	33-11/16	3/16	14-1/4	14-11/16	47	6	8	1/2	66	74
	B4-35EI-42	B5-35EI-42	42	51	7-7/16	7-15/16	15-1/8	39-1/2	38-15/16	5/16	15-15/16	16-5/16	53	7-1/2	9-1/2	5/8	83	92
	B4-35EI-48	B5-35EI-48	48	57	7-7/16	7-15/16	17-1/8	44-3/4	44-1/4	5/16	17-1/16	17-1/2	59	7-1/2	9-1/2	5/8	91	102
45°	B4-45EI-18	B5-45EI-18	18	27	6-15/16	7-7/16	7-1/8	17-1/8	16-1/2	3/16	11-1/2	11-7/8	29	6	8	1/2	34	37
	B4-45EI-24	B5-45EI-24	24	33	6-15/16	7-7/16	9-1/8	25-15/16	21-5/16	3/16	12-7/8	13-3/16	35	6	8	1/2	39	45
	B4-45EI-30	B5-45EI-30	30	39	6-15/16	7-7/16	11-1/8	26-13/16	26-1/8	3/16	14-5/16	14-11/16	41	6	8	1/2	49	56
	B4-45EI-36	B5-45EI-36	36	45	6-15/16	7-7/16	13-1/8	31-1/2	30-13/16	3/16	15-13/16	16-13/16	47	6	8	1/2	68	76
	B4-45EI-42	B5-45EI-42	42	51	7-7/16	7-15/16	15-1/8	37-7/16	35-3/4	5/16	17-11/16	18-1/16	53	7-1/2	9-1/2	5/8	85	94
	B4-45EI-48	B5-45EI-48	48	57	7-7/16	7-15/16	17-1/8	41-1/2	40-9/16	5/16	19-1/16	19-1/2	59	7-1/2	9-1/2	5/8	93	104

## Urathon® Return Roll – 5” Diameter

5" PART NUMBERS	BW	A	B	C	WT***
B5-RETU-18	18	27	21-3/8	28-7/16	21
B5-RETU-24	24	33	27-3/8	34-7/16	24
B5-RETU-30	30	39	33-3/8	40-7/16	28
B5-RETU-36	36	45	39-3/8	46-7/16	32
B5-RETU-42	42	51	45-3/8	52-7/16	36
B5-RETU-48	48	57	51-3/8	58-7/16	40

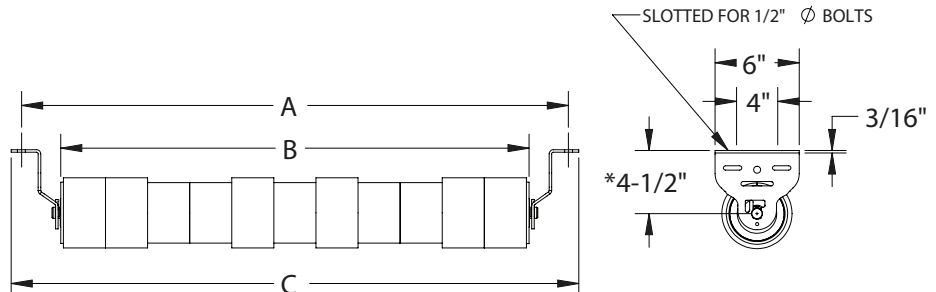

Note: Spiral Urathon is only available in 6" diameter.

\* Belt Width (Reinforcing on 36" BW - 48" BW Impact Frame.)

\*\* Recommended Bolt Pattern - See page 75 for minimum and maximum dimensions.

\*\*\*All weights include brackets, individual bracket weights are listed on page 74 and 75. Brackets are sold separately.



# CEMA B Idlers

## Return Idlers – 4" & 5" Diameter

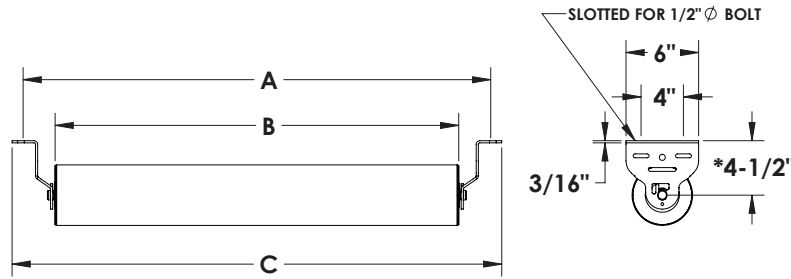

PART NUMBER		BW	A	B	C	WT (#)*	
4"	5"					4"	5"
B4-RET-14	B5-RET-14	14	23	17-3/8	24-7/16	14	18
B4-RET-16	B5-RET-16	16	25	19-3/8	26-7/16	15	20
B4-RET-18	B5-RET-18	18	27	21-3/8	28-7/16	16	21
B4-RET-20	B5-RET-20	20	29	23-3/8	30-7/16	17	23
B4-RET-24	B5-RET-24	24	33	27-3/8	34-7/16	19	26
B4-RET-30	B5-RET-30	30	39	33-3/8	40-7/16	22	30
B4-RET-36	B5-RET-36	36	45	39-3/8	46-7/16	25	35
B4-RET-42	B5-RET-42	42	51	45-3/8	52-7/16	29	39
B4-RET-48	B5-RET-48	48	57	51-3/8	58-7/16	32	44

CEMA B

## Flat Idlers – 4" & 5" Diameter

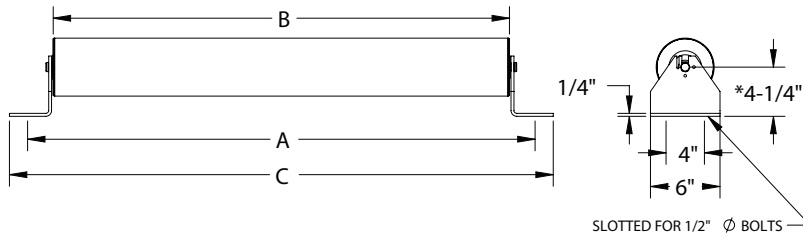

PART NUMBER		BW	A	B	C	WT (#)*	
4"	5"					4"	5"
B4-FLT-14	B5-FLT-14	14	23	17-3/8	24-15/16	16	21
B4-FLT-16	B5-FLT-16	16	25	19-3/8	26-15/16	18	22
B4-FLT-18	B5-FLT-18	18	27	21-3/4	26-15/16	19	24
B4-FLT-20	B5-FLT-20	20	29	23-3/8	30-15/16	20	25
B4-FLT-24	B5-FLT-24	24	33	27-3/8	34-15/16	22	28
B4-FLT-30	B5-FLT-30	30	39	33-3/8	40-15/16	25	33
B4-FLT-36	B5-FLT-36	36	45	39-3/8	46-15/16	28	37
B4-FLT-42	B5-FLT-42	42	51	45-3/8	52-15/16	31	42
B4-FLT-48	B5-FLT-48	48	57	51-3/8	58-15/16	34	46

## Rubber Cushion Return Idlers – 4" & 5"

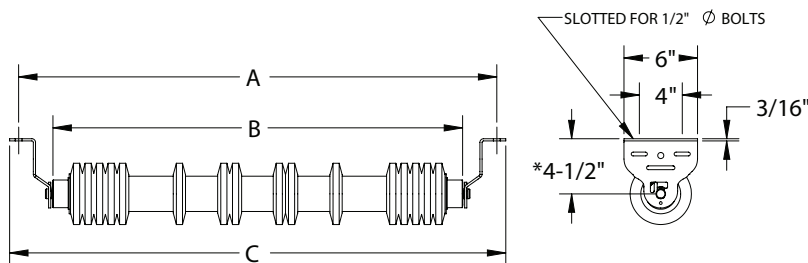

PART NUMBER		BW	A	B	C	WT (#)*	
4"	5"					4"	5"
B4-RETI-18	B5-RETI-18	18	27	21-7/16	28-7/16	19	21
B4-RETI-20	B5-RETI-20	20	29	23-7/16	30-7/16	20	23
B4-RETI-24	B5-RETI-24	24	33	27-7/16	34-7/16	23	26
B4-RETI-30	B5-RETI-30	30	39	33-7/16	40-7/16	26	30
B4-RETI-36	B5-RETI-36	36	45	39-7/16	46-7/16	30	34
B4-RETI-42	B5-RETI-42	42	51	45-7/16	52-7/16	34	38
B4-RETI-48	B5-RETI-48	48	57	51-7/16	58-7/16	37	41

## Rubber Cushion Flat Idlers – 4" & 5"

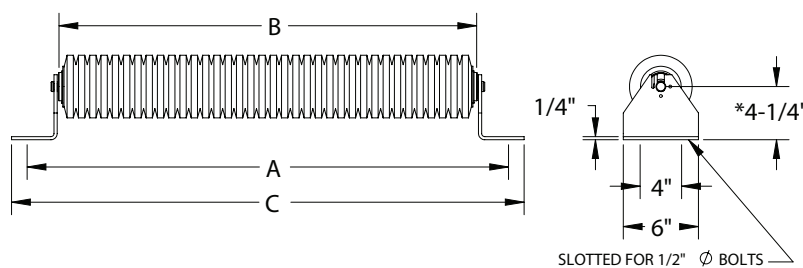

PART NUMBER		BW	A	B	C	WT (#)*	
4"	5"					4"	5"
B4-FLTI-18	B5-FLTI-18	18	27	21-7/16	28-15/16	23	28
B4-FLTI-24	B5-FLTI-24	24	33	27-7/16	34-15/16	28	34
B4-FLTI-30	B5-FLTI-30	30	39	33-7/16	40-15/16	33	40
B4-FLTI-36	B5-FLTI-36	36	45	39-7/16	46-15/16	37	46
B4-FLTI-42	B5-FLTI-42	42	51	45-7/16	52-15/16	42	52
B4-FLTI-48	B5-FLTI-48	48	57	51-7/16	58-15/16	47	59

\* All weights include brackets, individual bracket weights are listed on page 74 and 75. Brackets are sold separately.

# CEMA B Idlers

## Self-Aligning Troughing Idlers – 4" & 5"

CEMA B

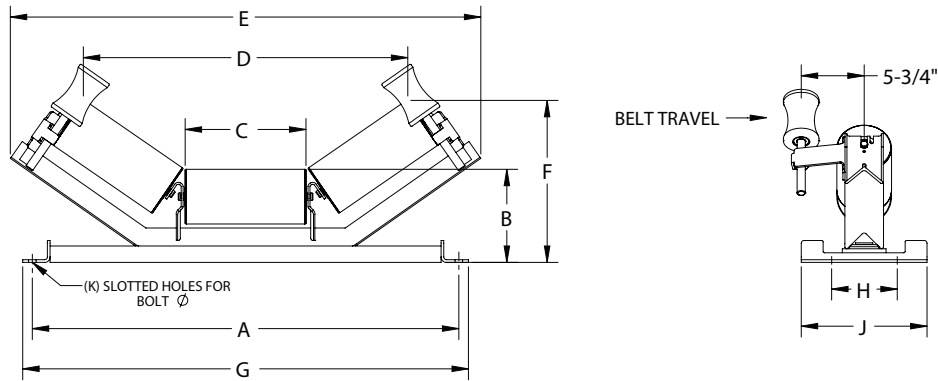

	PART NUMBER		BW	A	B		C	D		E	F		G	H	J	K	WT (#)	
	4"	5"			4"	5"		4"	5"		4"	5"					4"	5"
20°	B4-20EA-18	B5-20EA-18	18	27	8	8-1/2	7-1/16	21-3/4	21-7/16	30 5/8	10-1/2	10-15/16	28-3/4	6	11-1/2	5/8	73	80
	B4-20EA-24	B5-20EA-24	24	33	8	8-1/2	9-1/16	27-9/16	27-3/16	36-3/8	11-3/16	11-5/8	34-3/4	6	11-1/2	5/8	82	90
	B4-20EA-30	B5-20EA-30	30	39	8	8-1/2	11-1/16	33-5/16	33	42-3/16	11-7/8	12-3/8	40-3/4	6	11-1/2	5/8	95	103
	B4-20EA-36	B5-20EA-36	36	45	8	8-1/2	13-1/16	39-1/16	38-11/16	47-15/16	12-9/16	13-1/16	46-3/4	6	11-1/2	5/8	103	113
	B4-20EA-42	B5-20EA-42	42	51	8-3/8	8-7/8	15-1/16	44-13/16	44-1/2	54	13-5/8	14-1/8	52-3/4	6	11-1/2	5/8	113	134
	B4-20EA-48	B5-20EA-48	48	57	8-3/8	8-7/8	17-1/16	50-9/16	50-1/4	59-3/4	14-5/16	14-13/16	58-3/4	6	11-1/2	5/8	123	145
35°	B4-35EA-18	B5-35EA-18	18	27	8	8-1/2	7-1/16	19-11/16	19-3/16	32-7/16	12-1/16	12-1/2	28-3/4	6	11-1/2	5/8	75	80
	B4-35EA-24	B5-35EA-24	24	33	8	8-1/2	9-1/16	24-15/16	24-7/16	37-11/16	13-1/4	13-5/8	34-3/4	6	11-1/2	5/8	84	91
	B4-35EA-30	B5-35EA-30	30	39	8	8-1/2	11-1/16	30-1/4	29-11/16	43	14-3/8	14-13/16	40-3/4	6	11-1/2	5/8	96	105
	B4-35EA-36	B5-35EA-36	36	45	8	8-1/2	13-1/16	35-1/2	34-15/16	48-5/16	15-9/16	15-15/16	46-3/4	6	11-1/2	5/8	105	115
	B4-35EA-42	B5-35EA-42	42	51	8-3/8	8-7/8	15-1/16	40-13/16	40-3/16	54	17-1/16	17-1/2	52-3/4	6	11-1/2	5/8	125	136
	B4-35EA-48	B5-35EA-48	48	57	8-3/8	8-7/8	17-1/16	46-1/16	45-1/2	59-5/16	18-1/4	18-5/8	58-3/4	6	11-1/2	5/8	135	148
45°	B4-45EA-18	B5-45EA-18	18	27	8	8-1/2	7-1/16	17-13/16	17-1/4	31	12-13/16	13-3/16	28-3/4	6	11-1/2	5/8	75	81
	B4-45EA-24	B5-45EA-24	24	33	8	8-1/2	9-1/16	22-13/16	22-1/8	34-7/16	14-3/8	14-11/16	34-3/4	6	11-1/2	5/8	84	91
	B4-45EA-30	B5-45EA-30	30	39	8	8-1/2	11-1/16	27-13/16	27-3/16	40-15/16	15-3/4	16-1/16	40-3/4	6	11-1/2	5/8	97	105
	B4-45EA-36	B5-45EA-36	36	45	8	8-1/2	13-1/16	32-11/16	32	45-13/16	17-1/8	17-1/2	46-3/4	6	11-1/2	5/8	105	115
	B4-45EA-42	B5-45EA-42	42	51	8-3/8	8-7/8	15-1/16	40-3/4	40-1/8	54-3/16	17-1/2	17-7/8	52-3/4	6	11-1/2	5/8	126	137
	B4-45EA-48	B5-45EA-48	48	57	8-3/8	8-7/8	17-1/16	45-3/4	45-1/8	59-3/16	18-13/16	19-3/16	58-3/4	6	11-1/2	5/8	137	149

## Self-Aligning Return Idlers – 4" & 5" Diameter

PART NUMBER		BW	A	B	C	D	WT (#)*	
4"	5"						4"	5"
B4-RETA-18	B5-RETA-18	18	27	21-3/8	29-1/2	25-5/8	62	68
B4-RETA-24	B5-RETA-24	24	33	27-3/8	35-1/2	31-5/8	70	77
B4-RETA-30	B5-RETA-30	30	39	33-3/8	41-1/2	37-5/8	80	88
B4-RETA-36	B5-RETA-36	36	45	39-3/8	47-1/2	43-5/8	88	97
B4-RETA-42	B5-RETA-42	42	51	45-3/8	53-1/2	49-5/8	104	115
B4-RETA-48	B5-RETA-48	48	57	51-3/8	59-1/2	55-5/8	113	125

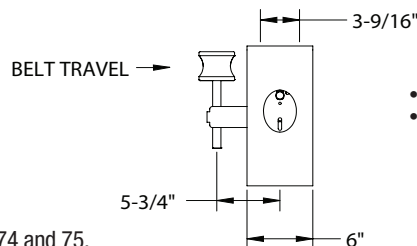
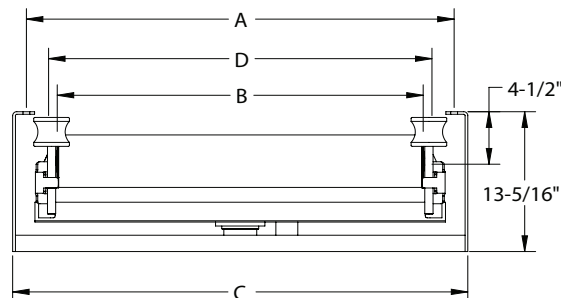

- Bigfoot bolting pattern available
- Lagged roller option available

\* All weights include brackets, individual bracket weights are listed on page 74 and 75. Brackets are sold separately.

NOTE: Also available in Bi-Directional. Designated by (BA).

# CEMA B Idlers

## Offset Center Roll Idlers – 4" & 5" Diameter

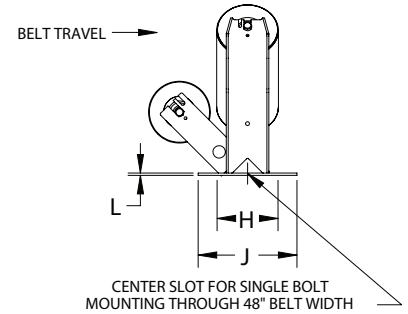
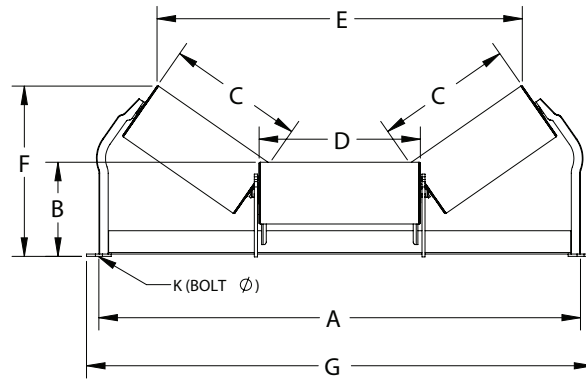

CEMA B

	PART NUMBER		BW	A	B		C	D	E		F		G	H*	J	K	L	WT (#)	
	4"	5"			4"	5"			4"	5"	4"	5"						4"	5"
20°	B4-20GO-18	B5-20GO-18	18	27	7-3/16	7-11/16	7-1/16	9-1/16	21-11/16	21-7/16	9-3/8	9-7/8	29	6	8	1/2	3/16	31	37
	B4-20GO-24	B5-20GO-24	24	33	7-3/16	7-11/16	9-1/16	11-1/16	27-7/16	27-3/16	10-1/16	10-9/16	35	6	8	1/2	3/16	36	43
	B4-20GO-30	B5-20GO-30	30	39	7-3/16	7-11/16	11-1/16	13-1/16	33-3/16	32-15/16	10-13/16	11-5/16	41	6	8	1/2	3/16	43	52
	B4-20GO-36	B5-20GO-36	36	45	7-3/16	7-11/16	13-1/16	15-1/16	39	38-11/16	11-1/2	12	47	6	9-1/2	1/2	5/16	49	59
	B4-20GO-42	B5-20GO-42	42	51	7-11/16	8-3/16	15-1/16	17-1/16	44-3/4	44-7/16	12-11/16	13-3/16	53	6	9-1/2	5/8	5/16	64	76
	B4-20GO-48	B5-20GO-48	48	57	7-11/16	8-3/16	17-1/16	19-1/16	50-1/2	50-3/16	13-3/8	13-7/8	59	6	9-1/2	5/8	5/16	70	84
35°	B4-35GO-18	B5-35GO-18	18	27	7-1/16	7-9/16	7-1/16	9-1/16	19-5/8	19	11-1/16	11-7/16	29	6	8	1/2	3/16	32	38
	B4-35GO-24	B5-35GO-24	24	33	7-1/16	7-9/16	9-1/16	11-1/16	24-7/8	24-5/16	12-3/16	12-5/8	35	6	8	1/2	3/16	37	44
	B4-35GO-30	B5-35GO-30	30	39	7-1/8	7-5/8	11-1/16	13-1/16	30-3/16	29-9/16	13-3/16	13-13/16	41	6	8	1/2	3/16	45	54
	B4-35GO-36	B5-35GO-36	36	45	7-1/8	7-5/8	13-1/16	15-1/16	35-7/16	34-7/8	14-9/16	14-15/16	47	6	9-1/2	1/2	5/16	50	61
	B4-35GO-42	B5-35GO-42	42	51	7-5/8	8-1/8	15-1/16	17-1/16	40-11/16	40-1/8	16-3/16	16-9/16	53	6	9-1/2	5/8	5/16	66	78
	B4-35GO-48	B5-35GO-48	48	57	7-5/8	8-1/8	17-1/16	19-1/16	46	45-3/8	17-5/16	17-3/4	59	6	9-1/2	5/8	5/16	72	86
45°	B4-45GO-18	B5-45GO-18	18	27	7-1/4	7-3/4	7-1/16	9-1/16	18-3/16	17-7/16	11-7/8	12-1/4	29	6	8	1/2	3/16	32	38
	B4-45GO-24	B5-45GO-24	24	33	7-1/4	7-3/4	9-1/16	11-1/16	23	22-1/4	13-5/16	13-5/8	35	6	8	1/2	3/16	37	45
	B4-45GO-30	B5-45GO-30	30	39	7-5/16	7-13/16	11-1/16	13-1/16	27-13/16	27-1/8	14-3/4	15-1/8	41	6	8	1/2	3/16	46	55
	B4-45GO-36	B5-45GO-36	36	45	7-5/16	7-13/16	13-1/16	15-1/16	32-5/8	31-15/16	16-3/16	16-1/2	47	6	9-1/2	1/2	5/16	51	62
	B4-45GO-42	B5-45GO-42	42	51	7-7/16	7-15/16	15-1/16	17-1/16	37-1/2	36-3/4	18-1/16	18-7/16	53	6	9-1/2	5/8	5/16	67	79
	B4-45GO-48	B5-45GO-48	48	57	7-7/16	7-15/16	17-1/16	19-3/8	42-5/16	41-9/16	19-1/2	19-15/16	59	6	9-1/2	5/8	5/16	74	87

\* Recommended Bolt Pattern - See page 75 for minimum and maximum dimensions.

# CEMA B Idlers

## Channel Mount – 4" & 5" Diameter

CEMA B

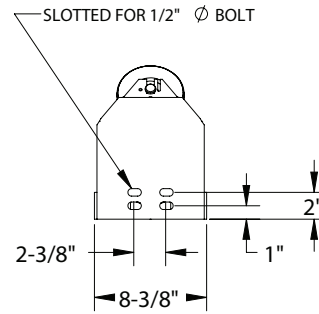
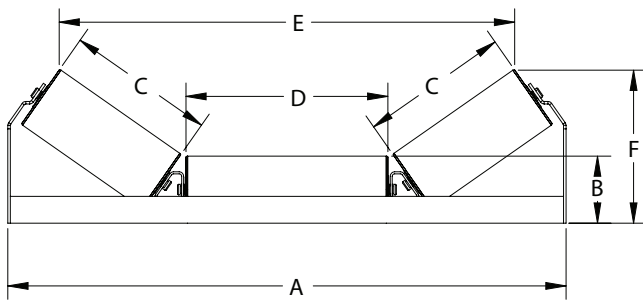

	PART NUMBER		BW	A	B		C	D	E		F		WT (#)	
	4"	5"			4"	5"			4"	5"	4"	5"	4"	5"
20°	B4-20CM-18	B5-20CM-18	18	23-5/8	4-7/16	4-15/16	6-1/16	7-1/16	20-5/16	19-15/16	6-5/8	7-1/8	30	35
	B4-20CM-24	B5-20CM-24	24	29-5/8	4-7/16	4-15/16	7-1/16	11-1/16	26-3/16	25-13/16	7	7-7/16	36	43
	B4-20CM-30	B5-20CM-30	30	35-5/8	4-7/16	4-15/16	9-1/16	13-1/16	31-15/16	31-9/16	7-11/16	8-1/8	42	50
	B4-20CM-36	B5-20CM-36	36	41-5/8	4-7/16	4-15/16	11-1/16	15-1/16	37-11/16	37-5/16	8-5/16	8-13/16	49	62
	B4-20CM-42	B5-20CM-42	42	47-5/8	4-7/16	4-15/16	13-1/16	17-1/16	43-7/16	43-1/16	9	9-1/2	55	66
	B4-20CM-48	B5-20CM-48	48	53-5/8	4-7/16	4-15/16	15-1/16	19-1/16	49-3/16	48-13/16	9-11/16	10-3/16	60	73
35°	B4-35CM-18	B5-35CM-18	18	23-5/8	4-7/16	4-15/16	6-1/16	7-1/16	18-7/16	17-13/16	8-1/8	8-1/2	35	41
	B4-35CM-24	B5-35CM-24	24	29-5/8	4-7/16	4-15/16	7-1/16	11-1/16	24-1/16	23-1/2	8-11/16	9-1/16	41	48
	B4-35CM-30	B5-35CM-30	30	35-5/8	4-7/16	4-15/16	9-1/16	13-1/16	29-5/16	28-3/4	9-13/16	10-1/4	48	56
	B4-35CM-36	B5-35CM-36	36	41-5/8	4-7/16	4-15/16	11-1/16	15-1/16	34-5/8	34	10-15/16	11-3/8	55	64
	B4-35CM-42	B5-35CM-42	42	47-5/8	4-7/16	4-15/16	13-1/16	17-1/16	39-7/8	39-5/16	12-1/8	12-1/2	62	72
	B4-35CM-48	B5-35CM-48	48	53-5/8	4-7/16	4-15/16	15-1/16	19-1/16	45-3/16	44-9/16	13-1/4	13-11/16	86	81

Note: Also available in standard mount designated by SM

## Channel Mount Impact Idlers – 4" & 5" Diameter

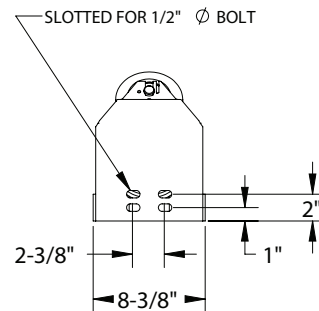
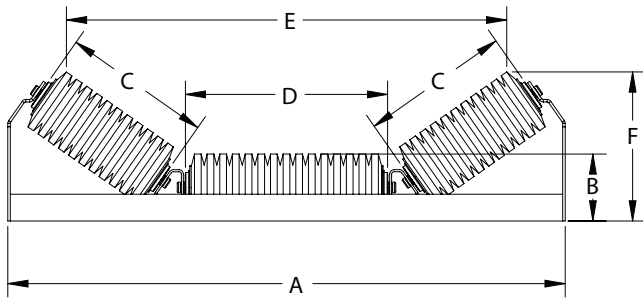

	PART NUMBER		BW	A	B		C	D	E		F		WT (#)	
	4"	5"			4"	5"			4"	5"	4"	5"	4"	5"
20°	B4-20CMI-18	B5-20CMI-18	18	23-5/8	4-7/16	4-15/16	6-1/8	7-1/8	19	18-11/16	6-7/16	6-15/16	32	36
	B4-20CMI-24	B5-20CMI-24	24	29-5/8	4-7/16	4-15/16	7-1/8	11-1/8	24-15/16	24-9/16	6-13/16	7-1/4	40	45
	B4-20CMI-30	B5-20CMI-30	30	35-5/8	4-7/16	4-15/16	9-1/8	13-1/8	30-11/16	30-5/16	7-1/2	7-15/16	48	54
	B4-20CMI-36	B5-20CMI-36	36	41-5/8	4-7/16	4-15/16	11-1/8	15-1/8	36-7/16	36-1/16	8-3/16	8-5/8	55	63
	B4-20CMI-42	B5-20CMI-42	42	47-5/8	4-7/16	4-15/16	13-1/8	17-1/8	42-3/16	41-7/8	8-7/8	9-5/16	63	72
	B4-20CMI-48	B5-20CMI-48	48	53-5/8	4-7/16	4-15/16	15-1/8	19-1/8	47-15/16	48-3/16	9-9/16	10	71	81
35°	B4-35CMI-18	B5-35CMI-18	18	23-5/8	4-7/16	4-15/16	6-1/8	7-1/8	17-5/16	16-3/4	7-13/16	8-3/16	37	41
	B4-35CMI-24	B5-35CMI-24	24	29-5/8	4-7/16	4-15/16	7-1/8	11-1/8	22-15/16	22-3/8	8-3/8	8-3/4	48	50
	B4-35CMI-30	B5-35CMI-30	30	35-5/8	4-7/16	4-15/16	9-1/8	13-1/8	28-3/16	28-3/8	9-1/2	9-7/8	54	60
	B4-35CMI-36	B5-35CMI-36	36	41-5/8	4-7/16	4-15/16	11-1/8	15-1/8	33-1/2	35-13/16	10-11/16	11-1/16	62	69
	B4-35CMI-42	B5-35CMI-42	42	47-5/8	4-7/16	4-15/16	13-1/8	17-1/8	38-3/4	38-3/16	11-13/16	15-1/4	70	79
	B4-35CMI-48	B5-35CMI-48	48	53-5/8	4-7/16	4-15/16	15-1/8	19-1/8	44-1/16	43-7/16	12-15/16	13-3/8	78	88

Note: Also available in standard mount designated by SMI

# CEMA C Idlers

## Troughing Idlers (Equal Length Rollers) – 4" Diameter

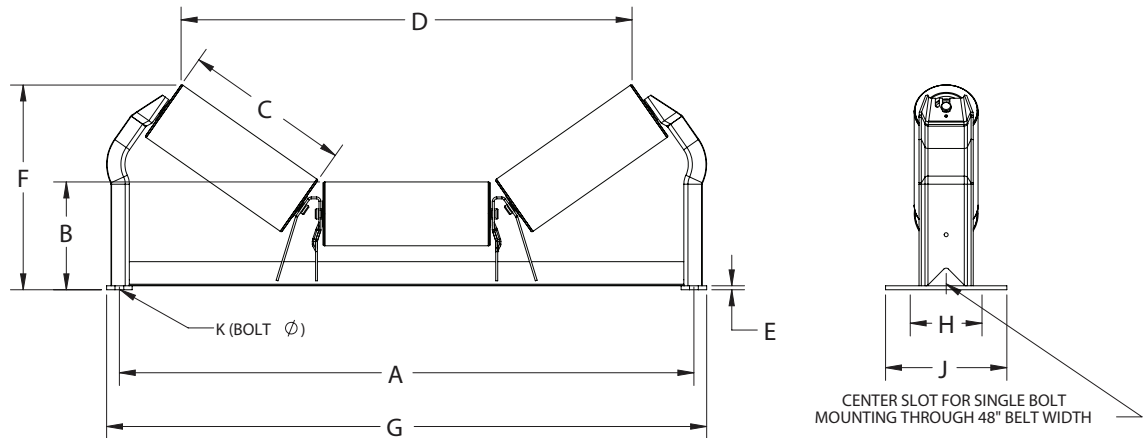

CEMA C

	4" PART NUMBER*	BW	A	B	C	D	E	F	G	H**	J	K	WT (#)
20°	C4-20E-18	18	27	7-13/16	7	22-3/16	3/16	10-5/16	29	6	8	1/2	33
	C4-20E-24	24	33	7-15/16	9	27-15/16	5/16	11-1/16	35	6	9-1/2	5/8	40
	C4-20E-30	30	39	7-15/16	11	33-11/16	5/16	11-13/16	41	6	9-1/2	5/8	48
	C4-20E-36	36	45	7-15/16	13	39-7/16	5/16	12-1/2	47	6	9-1/2	5/8	54
	C4-20E-42	42	51	8-5/16	15	45-3/16	5/16	13-9/16	53	7-1/2	9-1/2	5/8	68
	C4-20E-48	48	57	8-5/16	17	51	5/16	14-1/4	59	7-1/2	9-1/2	5/8	75
	C4-20E-54	54	63	8-3/4	19	56-3/4	3/8	15-5/16	65-1/2	9	11	5/8	90
	C4-20E-60	60	69	8-3/4	21	62-1/2	3/8	16	71-1/2	9	11	5/8	97
35°	C4-35E-18	18	27	7-13/16	7	20-1/16	3/16	12	29	6	8	1/2	35
	C4-35E-24	24	33	7-15/16	9	25-5/16	5/16	13-5/16	35	6	9-1/2	5/8	42
	C4-35E-30	30	39	7-15/16	11	30-9/16	5/16	14-7/16	41	6	9-1/2	5/8	50
	C4-35E-36	36	45	7-15/16	13	35-7/8	5/16	15-5/8	47	6	9-1/2	5/8	56
	C4-35E-42	42	51	8-5/16	15	41-1/8	5/16	17-1/8	53	7-1/2	9-1/2	5/8	64
	C4-35E-48	48	57	8-5/16	17	46-3/8	5/16	18-5/16	59	7-1/2	9-1/2	5/8	78
	C4-35E-54	54	63	8-3/4	19	51-11/16	3/8	19-7/8	65-1/2	9	11	5/8	93
	C4-35E-60	60	69	8-3/4	21	56-15/16	3/8	21	71-1/2	9	11	5/8	101
45°	<del>C4-45E-18</del>	<del>18</del>	<del>27</del>	<del>7-13/16</del>	<del>7</del>	<del>18-3/4</del>	<del>3/16</del>	<del>13-1/8</del>	<del>29</del>	<del>6</del>	<del>8</del>	<del>1/2</del>	<del>36</del>
	C4-45E-24	24	33	7-15/16	9	23-9/16	5/16	14-5/8	35	6	9-1/2	5/8	43
	C4-45E-30	30	39	7-15/16	11	28-7/16	5/16	16-1/16	41	6	9-1/2	5/8	52
	C4-45E-36	36	45	7-15/16	13	33-1/4	5/16	17-1/2	47	6	9-1/2	5/8	58
	C4-45E-42	42	51	8-5/16	15	38-1/16	5/16	19-5/16	53	7-1/2	9-1/2	5/8	73
	C4-45E-48	48	57	8-5/16	17	42-15/16	5/16	20-11/16	59	7-1/2	9-1/2	5/8	80
	C4-45E-54	54	63	8-3/4	19	47-3/4	3/8	22-1/2	65-1/2	9	11	5/8	96
	C4-45E-60	60	69	8-3/4	21	52-9/16	3/8	23-15/16	71-1/2	9	11	5/8	104

\*Add MOX to the end of the part number to replace steel cans with Moxie Rolls  
 \*\* Recommended Bolt Pattern - See page 75 for minimum and maximum dimensions.

# CEMA C Idlers

## Troughing Idlers (Equal Length Rollers) – 5” Diameter

CEMA C

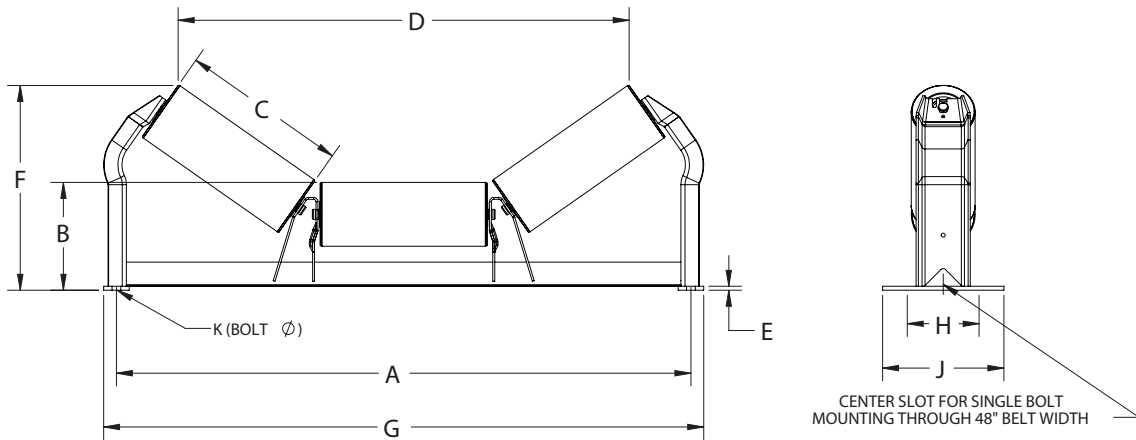

	5" PART NUMBER*	BW	A	B	C	D	E	F	G	H**	J	K	WT (#)
20°	C5-20E-18	18	27	8-5/16	7-1/16	21-7/8	3/16	10-3/4	29	6	8	1/2	39
	C5-20E-24	24	33	8-7/16	9-1/16	27-5/8	5/16	11-9/16	35	6	9-1/2	5/8	47
	C5-20E-30	30	39	8-7/16	11-1/16	33-7/16	5/16	12-5/16	41	6	9-1/2	5/8	57
	C5-20E-36	36	45	8-7/16	13-1/16	39-3/16	5/16	12-15/16	47	6	9-1/2	5/8	64
	C5-20E-42	42	51	8-13/16	15-1/16	44-15/16	5/16	14-1/16	53	7-1/2	9-1/2	5/8	80
	C5-20E-48	48	57	8-13/16	17-1/16	50-11/16	5/16	14-3/4	59	7-1/2	9-1/2	5/8	88
	C5-20E-54	54	63	9-1/4	19-1/16	56-7/16	3/8	15-13/16	65-1/2	9	11	5/8	104
	C5-20E-60	60	69	9-1/4	21-1/16	63-3/16	3/8	16-1/2	71-1/2	9	11	5/8	113
35°	C5-35E-18	18	27	8-5/16	7-1/16	19-9/16	3/16	12-7/16	29	6	8	1/2	41
	C5-35E-24	24	33	8-7/16	9-1/16	24-13/16	5/16	13-11/16	35	6	9-1/2	5/8	49
	C5-35E-30	30	39	8-7/16	11-1/16	30-1/16	5/16	14-7/8	41	6	9-1/2	5/8	59
	C5-35E-36	36	45	8-7/16	13-1/16	35-3/8	5/16	16-1/16	47	6	9-1/2	5/8	67
	C5-35E-42	42	51	8-13/16	15-1/16	40-5/8	5/16	17-9/16	53	7-1/2	9-1/2	5/8	82
	C5-35E-48	48	57	8-13/16	17-1/16	45-15/16	5/16	18-11/16	59	7-1/2	9-1/2	5/8	91
	C5-35E-54	54	63	9-1/4	19-1/16	51-1/8	3/8	20-1/4	65-1/2	9	11	5/8	108
	C5-35E-60	60	69	9-1/4	21-1/16	56-7/16	3/8	21-7/16	71-1/2	9	11	5/8	117
45°	<del>C5-45E-18</del>	<del>18</del>	<del>27</del>	<del>8-5/16</del>	<del>7-1/16</del>	<del>18-1/16</del>	<del>3/16</del>	<del>10-7/16</del>	<del>29</del>	<del>6</del>	<del>8</del>	<del>1/2</del>	<del>42</del>
	C5-45E-24	24	33	8-7/16	9-1/16	22-7/8	5/16	15	35	6	9-1/2	5/8	50
	C5-45E-30	30	39	8-7/16	11-1/16	27-13/16	5/16	16-7/16	41	6	9-1/2	5/8	61
	C5-45E-36	36	45	8-7/16	13-1/16	32-9/16	5/16	17-7/8	47	6	9-1/2	5/8	68
	C5-45E-42	42	51	8-13/16	15 1/16	37-7/16	5/16	19-5/8	53	7-1/2	9-1/2	5/8	84
	C5-45E-48	48	57	8-13/16	17-1/16	42-1/4	5/16	21-1/16	59	7-1/2	9-1/2	5/8	93
	C5-45E-54	54	63	9-1/4	19-1/16	47-1/16	3/8	22-7/8	65-1/2	9	11	5/8	110
	C5-45E-60	60	69	9-1/4	21-1/16	51-7/16	3/8	27-5/16	71-1/2	9	11	5/8	120

# CEMA C Idlers

## Troughed Idlers (Equal Length Rollers) – 6" Diameter

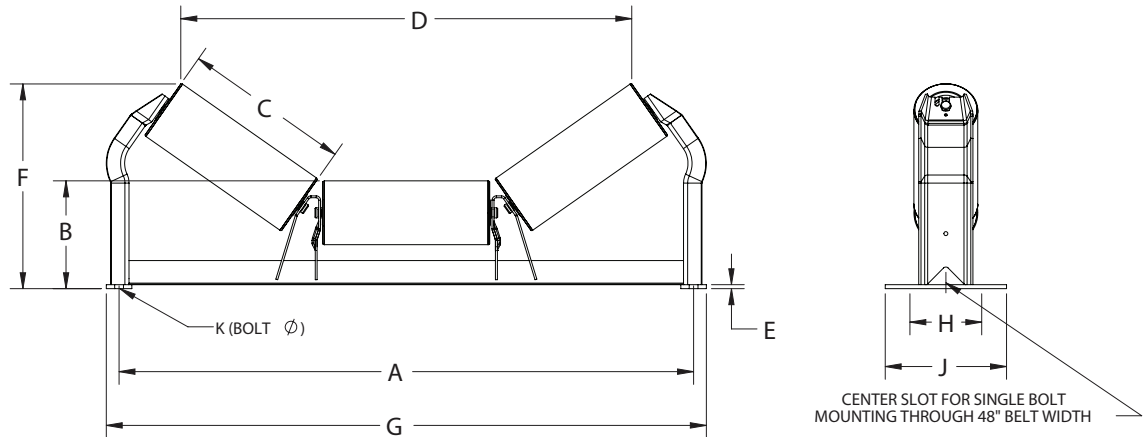

CEMA C

	6" PART NUMBER*	BW	A	B	C	D	E	F	G	H**	J	K	WT (#)
20°	C6-20E-18	18	27	8-13/16	7	21-9/16	3/16	11-1/4	29	6	8	1/2	46
	C6-20E-24	24	33	8-15/16	9	27-5/16	5/16	12-1/16	35	6	9-1/2	5/8	57
	C6-20E-30	30	39	8-15/16	11	33-1/16	5/16	12-3/4	41	6	9-1/2	5/8	69
	C6-20E-36	36	45	8-15/16	13	38-7/8	5/16	13-7/16	47	6	9-1/2	5/8	78
	C6-20E-42	42	51	9-5/16	15	44-5/8	5/16	14-1/2	53	7-1/2	9-1/2	5/8	95
	C6-20E-48	48	57	9-5/16	17	50-3/8	5/16	15-3/16	59	7-1/2	9-1/2	5/8	105
	C6-20E-54	54	63	9-3/4	19	56-1/8	3/8	16-5/16	65-1/2	9	11	5/8	124
	C6-20E-60	60	69	9-3/4	21	61-7/8	3/8	17	71-1/2	9	11	5/8	135
35°	C6-35E-18	18	27	8-13/16	7	18-15/16	3/16	12-13/16	29	6	8	1/2	48
	C6-35E-24	24	33	8-15/16	9	24-1/4	5/16	14-1/8	35	6	9-1/2	5/8	59
	C6-35E-30	30	39	8-15/16	11	29-1/2	5/16	15-1/4	41	6	9-1/2	5/8	71
	C6-35E-36	36	45	8-15/16	13	34-13/16	5/16	16-7/16	47	6	9-1/2	5/8	80
	C6-35E-42	42	51	9-5/16	15	40-1/16	5/16	17-15/16	53	7-1/2	9-1/2	5/8	98
	C6-35E-48	48	57	9-5/16	17	45-3/8	5/16	19-1/8	59	7-1/2	9-1/2	5/8	109
	C6-35E-54	54	63	9-3/4	19	50-5/8	3/8	20-11/16	65-1/2	9	11	5/8	128
	C6-35E-60	60	69	9-3/4	21	55-15/16	3/8	21-13/16	71-1/2	9	11	5/8	139
45°	<del>C6-45E-18</del>	<del>18</del>	<del>27</del>	<del>8-13/16</del>	<del>7</del>	<del>17-7/16</del>	<del>3/16</del>	<del>13-3/4</del>	<del>29</del>	<del>6</del>	<del>8</del>	<del>1/2</del>	<del>49</del>
	C6-45E-24	24	33	8-15/16	9	22-1/4	5/16	15-5/16	35	6	9-1/2	5/8	60
	C6-45E-30	30	39	8-15/16	11	27-1/8	5/16	16-3/4	41	6	9-1/2	5/8	73
	C6-45E-36	36	45	8-15/16	13	31-15/16	5/16	18-3/16	47	6	9-1/2	5/8	82
	C6-45E-42	42	51	9-5/16	15	36-3/4	5/16	19-15/16	53	7-1/2	9-1/2	5/8	100
	C6-45E-48	48	57	9-5/16	17	41-5/8	5/16	21-3/8	59	7-1/2	9-1/2	5/8	111
	C6-45E-54	54	63	9-3/4	19	46-7/16	3/8	23-3/16	65-1/2	9	11	5/8	130
	C6-45E-60	60	69	9-3/4	21	51-1/4	3/8	24-5/8	71-1/2	9	11	5/8	141

\*Add MOX to the end of the part number to replace steel cans with Moxie Rolls  
 \*\* Recommended Bolt Pattern - See page 75 for minimum and maximum dimensions.

# CEMA C Idlers

## Return Idlers – 4", 5" and 6" Diameter

PART NUMBER*			BW	A	B	C	WT (#)**		
4"	5"	6"					4"	5"	6"
C4-RET-16	C5-RET-16	C6-RET-16	16	25	19-5/16	26-7/16	16	21	27
C4-RET-18	C5-RET-18	C6-RET-18	18	27	21-5/16	28-7/16	17	23	30
C4-RET-20	C5-RET-20	C6-RET-20	20	29	23-5/16	30-7/16	18	24	31
C4-RET-24	C5-RET-24	C6-RET-24	24	33	27-5/16	34-7/16	21	27	37
C4-RET-30	C5-RET-30	C6-RET-30	30	39	33-5/16	40-7/16	24	32	43
C4-RET-36	C5-RET-36	C6-RET-36	36	45	39-5/16	46-7/16	27	37	50
C4-RET-42	C5-RET-42	C6-RET-42	42	51	45-5/16	52-7/16	31	41	57
C4-RET-48	C5-RET-48	C6-RET-48	48	57	51-5/16	58-7/16	32	46	63
C4-RET-54	C5-RET-54	C6-RET-54	54	63	57-5/16	64-7/16	42	54	74
C4-RET-60	C5-RET-60	C6-RET-60	60	69	63-5/16	70-7/16	45	60	81

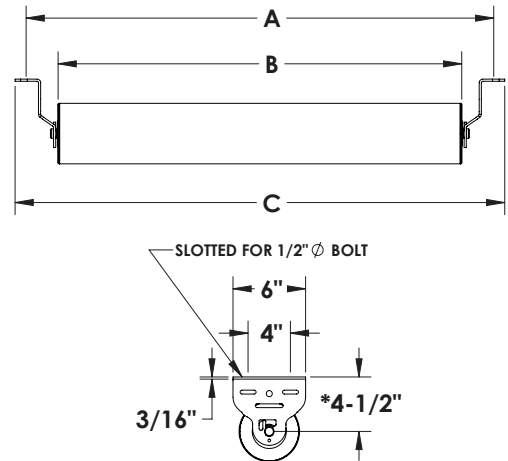

CEMA C

## Flat Idlers – 4", 5", & 6" Diameter

PART NUMBER			BW	A	B	C	WT (#)**		
4"	5"	6"					4"	5"	6"
C4-FLT-16	C5-FLT-16	-	16	25	19-5/16	26-15/16	19	23	-
C4-FLT-18	C5-FLT-18	C6-FLT-18	18	27	21-5/16	28-15/16	20	25	32
C4-FLT-20	C5-FLT-20	C6-FLT-20	20	29	23-5/16	30-15/16	21	27	34
C4-FLT-24	C5-FLT-24	C6-FLT-24	24	33	27-5/16	34-15/16	23	30	39
C4-FLT-30	C5-FLT-30	C6-FLT-30	30	39	33-5/16	40-15/16	26	34	46
C4-FLT-36	C5-FLT-36	C6-FLT-36	36	45	39-5/16	46-15/16	30	39	52
C4-FLT-42	C5-FLT-42	C6-FLT-42	42	51	45-5/16	52-15/16	33	44	59
C4-FLT-48	C5-FLT-48	C6-FLT-48	48	57	51-5/16	58-15/16	36	48	66
C4-FLT-54	C5-FLT-54	C6-FLT-54	54	63	57-5/16	64-15/16	44	57	76
C4-FLT-60	C5-FLT-60	C6-FLT-60	60	69	63-5/16	70-15/16	48	63	84

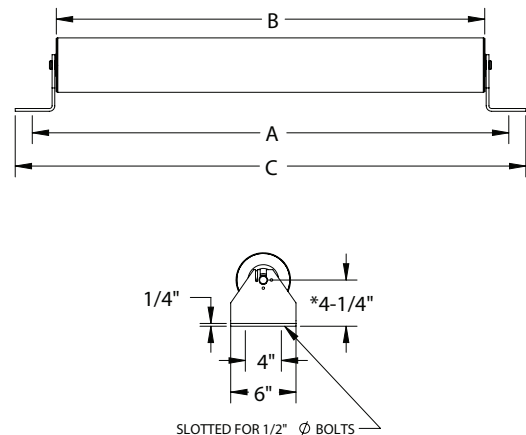

Note: Specify rise bracket requirement

## Garland Idlers – 4", 5", & 6" Diameter

4" PART NUMBER	BW	# OF ROLLS	A	B	C	WT (#)**
43-3400-16	16	3	21-5/16	8-1/16	6-1/16	15
43-3400-18	18	3	21-5/16	8-1/16	6-1/16	17
43-3400-24	24	3	25-7/8	9-11/16	7-11/16	20
43-3400-30	30	5	32-5/8	8-1/16	6-1/16	28
43-3400-36	36	5	36-13/16	9-1/16	7	31
43-3400-42	42	5	45-1/8	11-1/16	9	36
43-3400-48	48	5	53-7/16	13-1/16	11	42
43-3400-54	54	5	61-13/16	15-1/16	13	47
43-3400-60	60	5	70-1/8	17-1/16	15	53

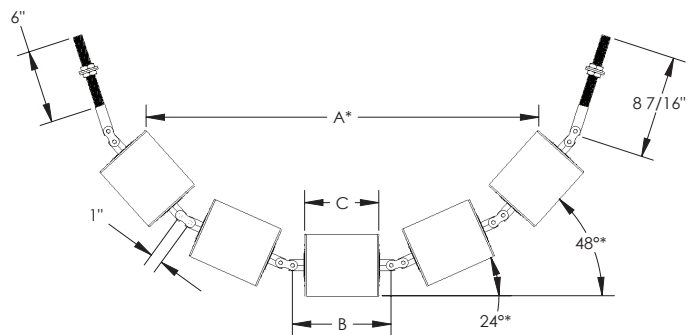

5" PART NUMBER	BW	# OF ROLLS	A	B	C	WT (#)**
43-3500-16	16	3	20-15/16	8-1/16	6-1/16	22
43-3500-18	18	3	20-15/16	8-1/16	6-1/16	22
43-3500-24	24	3	25-1/2	9-11/16	7-11/16	26
43-3500-30	30	5	32-3/16	8-1/16	6-1/16	37
43-3500-36	36	5	36-3/8	9-1/16	7	41
43-3500-42	42	5	44-11/16	11-1/16	9	48
43-3500-48	48	5	53	13-1/16	11	56
43-3500-54	54	5	61-3/8	15-1/16	13	64
43-3500-60	60	5	69-11/16	17-1/16	15	72

6" PART NUMBER	BW	# OF ROLLS	A	B	C	WT (#)**
43-3600-16	16	3	20-9/16	8-1/16	6-1/16	22
43-3600-18	18	3	20-9/16	8-1/16	6-1/16	22
43-3600-24	24	3	25-3/16	9-11/16	7-11/16	26
43-3600-30	30	5	31-9/16	8-1/16	6-1/16	37
43-3600-36	36	5	35-11/16	9-1/16	7	41
43-3600-42	42	5	44	11-1/16	9	48
43-3600-48	48	5	52-3/8	13-1/16	11	56
43-3600-54	54	5	60-11/16	15-1/16	13	64
43-3600-60	60	5	69	17-1/16	15	72

\*Add MOX to the end of the part number to replace steel cans with Moxie Rolls

\*\*All weights include brackets, individual bracket weights are listed on page 74 and 75. ✓ Meets CEMA D specifications



# CEMA C Idlers

## Rubber Cushion Impact Troughing Idlers – 4" Diameter

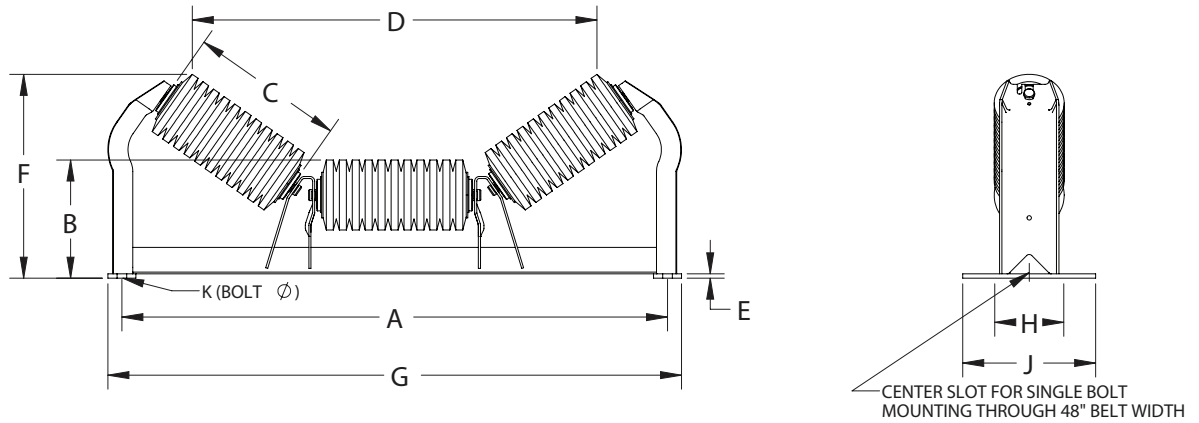

CEMA C

	4" PART NUMBER	BW*	A	B	C	D	E	F	G	H**	J	K	WT (#)
20°	C4-20EI-18	18	27	7-13/16	7-1/8	20-15/16	3/16	10-1/8	29	6	8	1/2	36
	C4-20EI-24	24	33	7-15/16	9-1/8	26-11/16	5/16	10-15/16	35	6	9-1/2	5/8	44
	C4-20EI-30	30	39	7-15/16	11-1/8	32-1/2	5/16	11-5/16	41	6	9-1/2	5/8	54
	C4-20EI-36	36	45	7-15/16	13-1/8	38-5/16	5/16	12-5/16	47	6	9-1/2	5/8	69
	C4-20EI-42	42	51	8-5/16	15-1/8	44-1/16	5/16	13-3/8	53	7-1/2	9-1/2	5/8	86
	C4-20EI-48	48	57	8-5/16	17-1/8	49-13/16	5/16	14-1/16	59	7-1/2	9-1/2	5/8	94
	C4-20EI-54	54	63	8-3/4	19-1/8	55-5/8	3/8	15-3/16	65-1/2	9	11	5/8	114
	C4-20EI-60	60	69	8-3/4	21-1/8	61-3/8	3/8	15-7/8	71-1/2	9	11	5/8	123
35°	C4-35EI-18	18	27	7-13/16	7-1/8	18-15/16	3/16	11-11/16	29	6	8	1/2	37
	C4-35EI-24	24	33	7-15/16	9-1/8	24-3/16	5/16	13	35	6	9-1/2	5/8	46
	C4-35EI-30	30	39	7-15/16	11-1/8	29-1/2	5/16	14-3/16	41	6	9-1/2	5/8	56
	C4-35EI-36	36	45	7-15/16	13-1/8	34-13/16	5/16	15-5/16	47	6	9-1/2	5/8	71
	C4-35EI-42	42	51	8-5/16	15-1/8	40-1/8	5/16	16-13/16	53	7-1/2	9-1/2	5/8	89
	C4-35EI-48	48	57	8-5/16	17-1/8	45-3/8	5/16	18	59	7-1/2	9-1/2	5/8	98
	C4-35EI-54	54	63	8-3/4	19-1/8	50-11/16	3/8	19-9/16	65-1/2	9	11	5/8	118
	C4-35EI-60	60	69	8-3/4	21-1/8	55-15/16	3/8	20-11/16	71-1/2	9	11	5/8	127
45°	<del>C4-45EI-18</del>	<del>18</del>	<del>27</del>	<del>7-13/16</del>	<del>7-1/8</del>	<del>17-3/4</del>	<del>3/16</del>	<del>12-11/16</del>	<del>29</del>	<del>6</del>	<del>8</del>	<del>1/2</del>	<del>39</del>
	C4-45EI-24	24	33	7-15/16	9-1/8	22-9/16	5/16	14-1/4	35	6	9-1/2	5/8	47
	C4-45EI-30	30	39	7-15/16	11-1/8	27-7/16	5/16	15-11/16	41	6	9-1/2	5/8	58
	C4-45EI-36	36	45	7-15/16	13-1/8	32-7/8	5/16	16-9/16	47	6	9-1/2	5/8	74
	C4-45EI-42	42	51	8-5/16	15-1/8	37-11/16	5/16	18-5/16	53	7-1/2	9-1/2	5/8	91
	C4-45EI-48	48	57	8-5/16	17-1/8	42-1/2	5/16	20-3/4	59	7-1/2	9-1/2	5/8	100
	C4-45EI-54	54	63	8-3/4	19-1/8	47-5/16	3/8	21-3/8	65-1/2	9	11	5/8	120
	C4-45EI-60	60	69	8-3/4	21-1/8	52-3/16	3/8	23	71-1/2	9	11	5/8	130

\* Belt Width (Reinforcing on 36" BW - 60" BW Impact Frame).

\*\* Recommended Bolt Pattern - See page 75 for minimum and maximum dimensions.

# CEMA C Idlers

## Rubber Cushion Impact Troughing Idlers – 5” Diameter

CEMA C

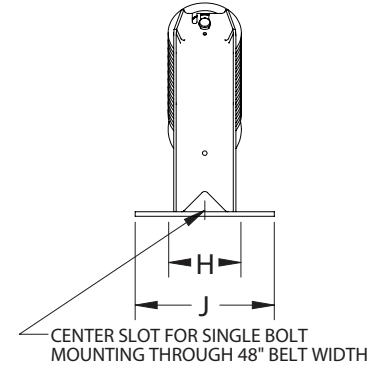
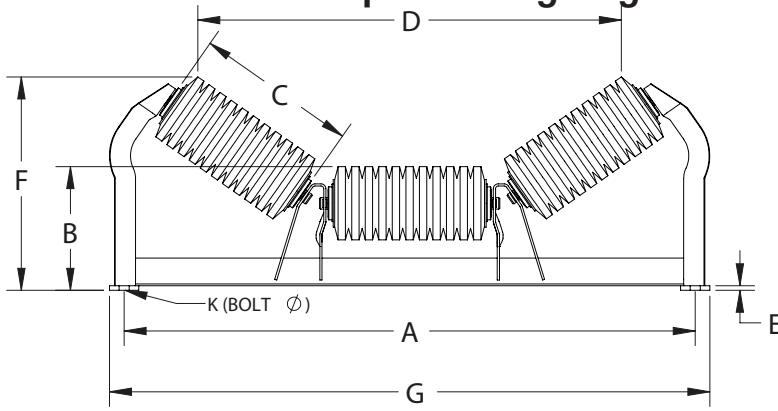

	5" PART NUMBER	BW*	A	B	C	D	E	F	G	H**	J	K	WT (#)
20°	C5-20EI-18	18	27	8-5/16	7-1/16	20-7/8	3/16	10-5/8	29	6	8	1/2	40
	C5-20EI-24	24	33	8-7/16	9-11/16	26-5/8	5/16	11-7/16	35	6	9-1/2	5/8	50
	C5-20EI-30	30	39	8-7/16	11-1/16	32-5/16	5/16	12-3/16	41	6	9-1/2	5/8	61
	C5-20EI-36	36	45	8-7/16	13-1/16	38-1/16	5/16	12-7/8	47	6	9-1/2	5/8	77
	C5-20EI-42	42	51	8-13/16	15-1/16	43-13/16	5/16	13-15/16	53	7-1/2	9-1/2	5/8	95
	C5-20EI-48	48	57	8-13/16	17-1/16	49-9/16	5/16	14-5/8	59	7-1/2	9-1/2	5/8	105
	C5-20EI-54	54	63	9-1/4	19-1/16	56-3/16	3/8	15-3/4	65-1/2	9	11	5/8	124
	C5-20EI-60	60	69	9-1/4	21-1/16	61-15/16	3/8	16-7/16	71-1/2	9	11	5/8	136
35°	C5-35EI-18	18	27	8-5/16	7-1/16	18-9/16	3/16	12-3/16	29	6	8	1/2	42
	C5-35EI-24	24	33	8-7/16	9-1/16	23-13/16	5/16	13-7/16	35	6	9-1/2	5/8	52
	C5-35EI-30	30	39	8-7/16	11-1/16	29-1/16	5/16	14-5/8	41	6	9-1/2	5/8	63
	C5-35EI-36	36	45	8-7/16	13-1/16	34-3/8	5/16	15-3/4	47	6	9-1/2	5/8	79
	C5-35EI-42	42	51	8-13/16	15-1/16	39-5/8	5/16	17-5/16	53	7-1/2	9-1/2	5/8	100
	C5-35EI-48	48	57	8-13/16	17-1/16	44-7/8	5/16	18-7/16	59	7-1/2	9-1/2	5/8	110
	C5-35EI-54	54	63	9-1/4	19-1/16	50-13/16	3/8	20-1/8	65-1/2	9	11	5/8	128
	C5-35EI-60	60	69	9-1/4	21-1/16	56-1/8	3/8	21-1/4	71-1/2	9	11	5/8	140
45°	<del>C5-45EI-18</del>	<del>18</del>	<del>27</del>	<del>8-5/16</del>	<del>7-1/16</del>	<del>17-1/4</del>	<del>3/16</del>	<del>10-1/8</del>	<del>29</del>	<del>6</del>	<del>8</del>	<del>1/2</del>	<del>40</del>
	C5-45EI-24	24	33	8-7/16	9-1/16	22-1/16	5/16	14-11/16	35	6	9-1/2	5/8	53
	C5-45EI-30	30	39	8-7/16	11-1/16	26-7/8	5/16	16-1/8	41	6	9-1/2	5/8	65
	C5-45EI-36	36	45	8-7/16	13-1/16	31-11/16	5/16	17-1/2	47	6	9-1/2	5/8	81
	C5-45EI-42	42	51	8-13/16	15-1/16	36-1/2	5/16	19-5/16	53	7-1/2	9-1/2	5/8	102
	C5-45EI-48	48	57	8-13/16	17-1/16	41-5/16	5/16	20-3/4	59	7-1/2	9-1/2	5/8	112
	C5-45EI-54	54	63	9-1/4	19-1/16	46-3/4	3/8	22-11/16	65-1/2	9	11	5/8	128
	C5-45EI-60	60	69	9-1/4	21-1/16	51-9/16	3/8	24-1/16	71-1/2	9	11	5/8	143

# CEMA C Idlers

## Rubber Cushion Impact Troughing Idlers – 6" Diameter

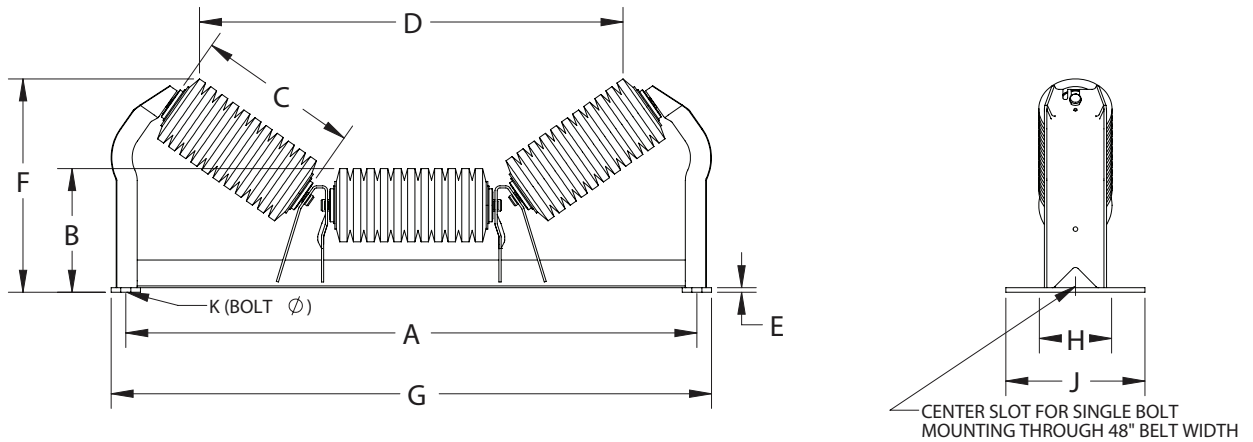

CEMA C

	6" PART NUMBER	BW*	A	B	C	D	E	F	G	H**	J	K	WT (#)
20°	C6-20EI-18	18	27	8-13/16	7-1/16	20-1/2	3/16	11-1/8	29	6	8	1/2	46
	C6-20EI-24	24	33	8-15/16	9-1/16	26-1/4	5/16	11-15/16	35	6	9-1/2	5/8	57
	C6-20EI-30	30	39	8-15/16	11-1/16	31-15/16	5/16	12-5/8	41	6	9-1/2	5/8	71
	C6-20EI-36	36	45	8-15/16	13-1/16	37-3/4	5/16	13-5/16	47	6	9-1/2	5/8	88
	C6-20EI-42	42	51	9-5/16	15-1/16	43-7/16	5/16	14-3/8	53	7-1/2	9-1/2	5/8	108
	C6-20EI-48	48	57	9-5/16	17-1/16	49-3/16	5/16	15-1/16	59	7-1/2	9-1/2	5/8	119
	C6-20EI-54	54	63	9-3/4	19	55-13/16	3/8	16-1/4	65-1/2	9	11	5/8	141
	C6-20EI-60	60	69	9-3/4	21	61-9/16	3/8	16-15/16	71-1/2	9	11	5/8	155
35°	C6-35EI-18	18	27	8-13/16	7-1/16	18	1/4	12-5/8	29	6	8	1/2	48
	C6-35EI-24	24	33	8-15/16	9-1/16	23-1/4	5/16	13	35	6	9-1/2	5/8	59
	C6-35EI-30	30	39	8-15/16	11-1/16	28-1/2	5/16	15-1/16	41	6	9-1/2	5/8	73
	C6-35EI-36	36	45	8-15/16	13-1/16	33-11/16	5/16	16-3/16	47	6	9-1/2	5/8	90
	C6-35EI-42	42	51	9-5/16	15-1/16	39	5/16	17-11/16	53	7-1/2	9-1/2	5/8	112
	C6-35EI-48	48	57	9-5/16	17-1/16	44-5/16	5/16	18-7/8	59	7-1/2	9-1/2	5/8	124
	C6-35EI-54	54	63	9-3/4	19	50-1/4	3/8	20-1/2	65-1/2	9	11	5/8	142
	C6-35EI-60	60	69	9-3/4	21	55-1/2	3/8	21-11/16	71-1/2	9	11	5/8	144
45°	C6-45EI-18	18	27	8-15/16	7	17-7/16	3/16	13-3/4	29	6	8	1/2	43
	C6-45EI-24	24	33	8-15/16	9	22-1/4	5/16	15-5/16	35	6	9-1/2	5/8	61
	C6-45EI-30	30	39	8-15/16	11	27-1/8	5/16	16-3/4	41	6	9-1/2	5/8	74
	C6-45EI-36	36	45	8-15/16	13	31-15/16	5/16	18-3/16	47	6	9-1/2	5/8	92
	C6-45EI-42	42	51	9-5/16	15	36-3/4	5/16	19-15/16	53	7-1/2	9-1/2	5/8	115
	C6-45EI-48	48	57	9-5/16	17	41-5/8	5/16	21-3/8	59	7-1/2	9-1/2	5/8	127
	C6-45EI-54	54	63	9-3/4	19	46-1/16	3/8	23	65-1/2	9	11	5/8	147
	C6-45EI-60	60	69	9-3/4	21	50-7/8	3/8	24-7/16	71-1/2	9	11	5/8	162

\* Belt Width (Reinforcing on 36" BW - 60" BW Impact Frame).

\*\* Recommended Bolt Pattern - See page 75 for minimum and maximum dimensions.

# CEMA C Idlers

## Rubber Cushion Return Idlers – 4", 5", & 6" Diameter

PART NUMBER			BW	A	B	C	WT (#)		
4"	5"	6"					4"	5"	6"
C4-RETI-18	C5-RETI-18	C6-RETI-18	18	27	21-3/8	28-7/16	20	23	26
C4-RETI-20	C5-RETI-20	C6-RETI-20	20	29	23-3/8	30-7/16	22	25	29
C4-RETI-24	C5-RETI-24	C6-RETI-24	24	33	27-3/8	34-7/16	25	28	32
C4-RETI-30	C5-RETI-30	C6-RETI-30	30	39	33-3/8	40-7/16	29	32	37
C4-RETI-36	C5-RETI-36	C6-RETI-36	36	45	39-3/8	46-7/16	34	37	43
C4-RETI-42	C5-RETI-42	C6-RETI-42	42	51	45-3/8	52-7/16	38	42	47
C4-RETI-48	C5-RETI-48	C6-RETI-48	48	57	51-3/8	58-7/16	42	46	51
C4-RETI-54	C5-RETI-54	C6-RETI-54	54	63	57-3/8	64-7/16	50	54	60
C4-RETI-60	C5-RETI-60	C6-RETI-60	60	69	63-3/8	70-7/16	55	60	66

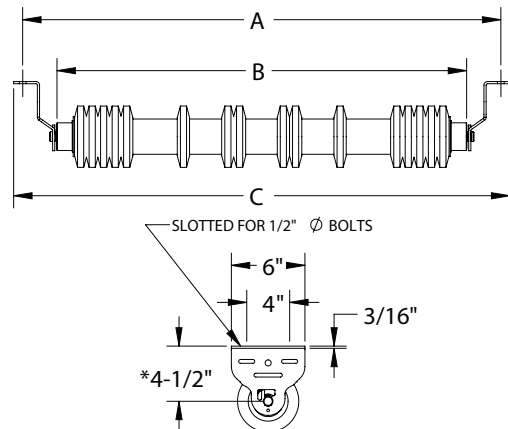

## Rubber Cushion Flat Idlers – 4", 5", & 6" Diameter

PART NUMBER			BW	A	B	C	WT (#)		
4"	5"	6"					4"	5"	6"
C4-FLTI-18	C5-FLTI-18	C6-FLTI-18	18	27	21-7/16	28-15/16	25	30	36
C4-FLTI-20	C5-FLTI-20	C6-FLTI-20	20	29	23-7/16	30-15/16	26	31	38
C4-FLTI-24	C5-FLTI-24	C6-FLTI-24	24	33	27-7/16	34-15/16	30	36	44
C4-FLTI-30	C5-FLTI-30	C6-FLTI-30	30	39	33-7/16	40-15/16	35	43	53
C4-FLTI-36	C5-FLTI-36	C6-FLTI-36	36	45	39-7/16	46-15/16	40	49	62
C4-FLTI-42	C5-FLTI-42	C6-FLTI-42	42	51	45-7/16	52-15/16	45	56	70
C4-FLTI-48	C5-FLTI-48	C6-FLTI-48	48	57	51-7/16	58-15/16	51	63	79
C4-FLTI-54	C5-FLTI-54	C6-FLTI-54	54	63	57-7/16	64-15/16	60	73	91
C4-FLTI-60	C5-FLTI-60	C6-FLTI-60	60	69	63-7/16	70-15/16	65	80	100

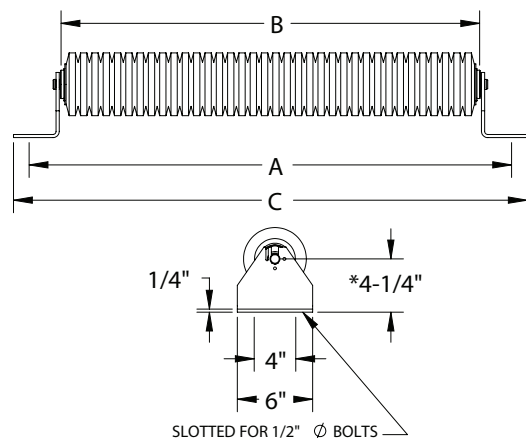

## V-Return Idlers – 4", 5", & 6" Diameter

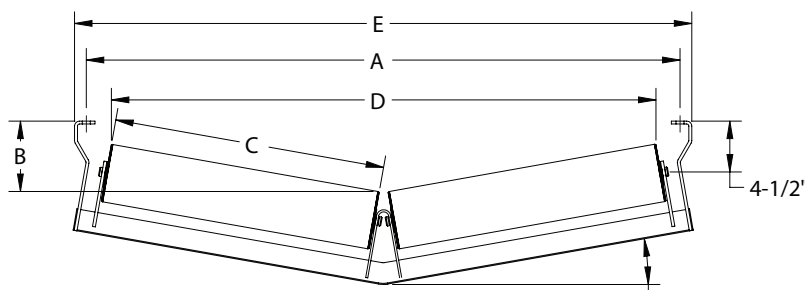

FOR WIDE BASE USE NEXT SIZE LARGER BELT WIDTH  
ALSO AVAILABLE IN 15"

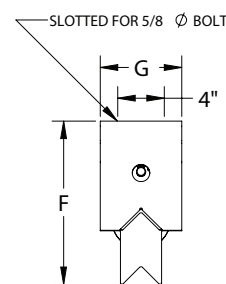

PART NUMBER			BW	A	B			C	D			E	F	WT (#)*		
4"	5"	6"			4"	5"	6"		4"	5"	6"			4"	5"	6"
C4-10RETV-24	C5-10RETV-24	C6-10RETV-24	24	33	4-15/16	4-7/16	3-15/16	14-3/8	28-7/8	28-13/16	28-5/8	35-1/8	12-3/8	42	49	58
C4-10RETV-30	C5-10RETV-30	C6-10RETV-30	30	39	5-1/2	5	4-1/2	17	34-3/16	34-1/16	33-7/8	41-1/8	12-7/8	46	55	67
C4-10RETV-36	C5-10RETV-36	C6-10RETV-36	36	45	6	5-1/2	5	20-3/8	40-15/16	40-7/8	40-11/16	47-1/8	13-3/8	52	62	74
C4-10RETV-42	C5-10RETV-42	C6-10RETV-42	42	51	6-1/2	6-1/16	5-9/16	23-3/8	46-5/8	46-1/2	46-3/8	53-1/8	14	56	68	82
C4-10RETV-48	C5-10RETV-48	C6-10RETV-48	48	57	7-1/16	6-9/16	6-1/16	26-1/2	52-7/8	52-3/4	52-9/16	59-1/8	14-1/2	61	74	92
C4-10RETV-54	C5-10RETV-54	C6-10RETV-54	54	63	7-9/16	7-1/8	6-5/8	29-1/4	58-3/16	58-1/8	57-15/16	65-1/8	15-3/8	82	96	114
C4-10RETV-60	C5-10RETV-60	C6-10RETV-60	60	69	8-1/8	7-5/8	7-1/8	32-1/2	64-11/16	64-9/16	64-3/8	71-1/8	15-7/8	89	105	127

# CEMA C Idlers

## Urathon® Return Rolls – 5" & 6" Diameter

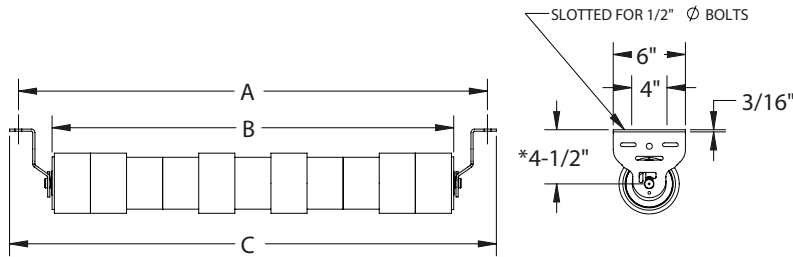

PART NUMBERS		BW	A	B	C	WT (#)**	
5"	6"					5"	6"
C5-RETU-18	C6-RETU-18	18	27	21-3/8	28-7/16	22	28
C5-RETU-24	C6-RETU-24	24	33	27-3/8	34-7/16	25	33
C5-RETU-30	C6-RETU-30	30	39	33-3/8	40-7/16	30	39
C5-RETU-36	C6-RETU-36	36	45	39-3/8	46-7/16	34	45
C5-RETU-42	C6-RETU-42	42	51	45-3/8	52-7/16	38	50
C5-RETU-48	C6-RETU-48	48	57	51-3/8	58-7/16	42	56
C5-RETU-54	C6-RETU-54	54	63	57-3/8	64-7/16	50	66
C5-RETU-60	C6-RETU-60	60	69	63-3/8	70-7/16	55	72

Note: Spiral Urathon is only available in 6" diameter. To order Spiral Urathon version add SP after RETU in the part number.

## Self-Aligning Troughing Idlers – 4" Diameter

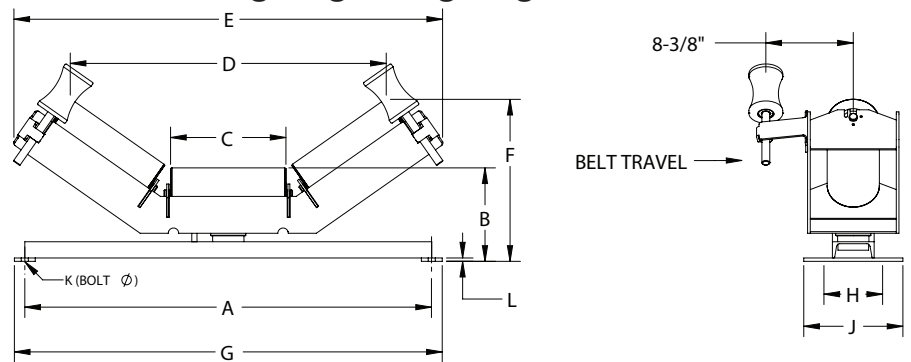

	4" PART NUMBER*	BW	A	B	C	D	E	F	G	H	J	K	L	WT(#)
20°	C4-20EA-18	18	27	8-3/8	7	23-3/16	31	11-1/16	29	6	8	1/2	3/16	80
	C4-20EA-24	24	33	8-1/2	9	28-15/16	36-3/4	11-7/8	35	6	9-1/2	1/2	5/16	91
	C4-20EA-30	30	39	8-1/2	11	34-11/16	42-9/16	12-9/16	41	6	9-1/2	1/2	5/16	100
	C4-20EA-36	36	45	8-1/2	13	40-7/16	48-5/16	13-1/4	47	6	9-1/2	1/2	5/16	109
	C4-20EA-42	42	51	9	15	46	54-3/16	14-7/16	53	7-1/2	9-1/2	5/8	5/16	123
	C4-20EA-48	48	57	9	17	51-3/4	60	15-1/8	59	7-1/2	9-1/2	5/8	5/16	133
	C4-20EA-54	54	63	9-1/16	19	57-1/2	65-3/4	15-7/8	65-1/2	9	11	5/8	3/8	145
	C4-20EA-60	60	69	9-1/16	21	63-5/16	72-1/2	16-9/16	71-1/2	9	11	5/8	3/8	155
35°	C4-35EA-18	18	27	8-3/8	7	20-1/4	30-3/8	12-3/4	29	6	8	1/2	3/16	81
	C4-35EA-24	24	33	8-1/2	9	25-9/16	35-11/16	14	35	6	9-1/2	1/2	5/16	91
	C4-35EA-30	30	39	8-1/2	11	30-13/16	40-15/16	15-1/8	41	6	9-1/2	1/2	5/16	101
	C4-35EA-36	36	45	8-1/2	13	36-1/16	46-1/4	16-5/16	47	6	9-1/2	1/2	5/16	110
	C4-35EA-42	42	51	9	15	41-1/16	51-3/16	17-15/16	53	7-1/2	9-1/2	5/8	5/16	123
	C4-35EA-48	48	57	9	17	46-5/16	56-1/2	19-1/8	59	7-1/2	9-1/2	5/8	5/16	133
	C4-35EA-54	54	63	9-1/16	19	51-5/8	61-3/4	20-5/16	65-1/2	9	11	5/8	3/8	145
	C4-35EA-60	60	69	9-1/16	21	56-7/8	67	21-7/16	71-1/2	9	11	5/8	3/8	156
45°	C4-45EA-18	18	27	8-3/8	7	19-7/16	30-11/16	13-5/8	29	6	8	1/2	3/16	82
	C4-45EA-24	24	33	8-1/2	9	24-1/4	35-1/2	15-1/8	35	6	9-1/2	1/2	5/16	93
	C4-45EA-30	30	39	8-1/2	11	29-1/16	40-5/16	16-9/16	41	6	9-1/2	1/2	5/16	102
	C4-45EA-36	36	45	8-1/2	13	33-7/8	45-3/16	18	47	6	9-1/2	1/2	5/16	111
	C4-45EA-42	42	51	9	15	38-5/16	50-5/16	20-1/4	53	7-1/2	9-1/2	5/8	5/16	137
	C4-45EA-48	48	57	9	17	43-1/8	55-1/8	21-5/16	59	7-1/2	9-1/2	5/8	5/16	135
	C4-45EA-54	54	63	9-1/16	19	47-15/16	59-15/16	22-13/16	65-1/2	9	11	5/8	3/8	147
	C4-45EA-60	60	69	9-1/16	21	52-13/16	64-3/4	24-3/16	71-1/2	9	11	5/8	3/8	157

\*Also available in bi-directional shoe-activating. Designated by (BA).

\*\*Weight of bracket included. Individual bracket weights are listed on page 74 and 75.

# CEMA C Idlers

## Self-Aligning Troughing Idlers – 5” & 6” Diameter

CEMA C

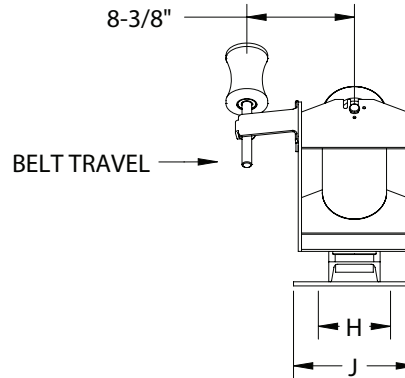
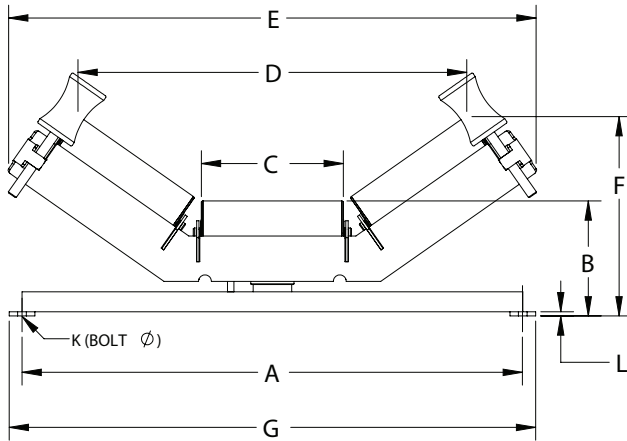

	PART NUMBER*		BW	A	B		C		D		E	F		G	H	J	K	L	WT (#)	
	5"	6"			5"	6"	5"	6"	5"	6"		5"	6"						5"	6"
20°	C5-20EA-18	C6-20EA-18	18	27	8-7/8	9-3/8	7-1/16	7	22-7/8	22-9/16	31	11-9/16	12	29	6	8	1/2	3/16	86	94
	C5-20EA-24	C6-20EA-24	24	33	9	9-1/2	9-1/16	9	28-5/8	28-5/16	36-3/4	12-3/8	12-13/16	35	6	9-1/2	1/2	5/16	98	108
	C5-20EA-30	C6-20EA-30	30	39	9	9-1/2	11-1/16	11	34-3/8	34-1/16	42-9/16	13-1/16	13-1/2	41	6	9-1/2	1/2	5/16	109	121
	C5-20EA-36	C6-20EA-36	36	45	9	9-1/2	13-1/16	13	40-1/8	39-13/16	48-5/16	13-3/4	14-3/16	47	6	9-1/2	1/2	5/16	120	134
	C5-20EA-42	C6-20EA-42	42	51	9-1/2	10	15-1/16	15	45-3/4	45-3/8	54-3/16	14-15/16	15-3/8	53	7-1/2	9-1/2	5/8	5/16	134	150
	C5-20EA-48	C6-20EA-48	48	57	9-1/2	10	17-1/16	17	51-1/2	51-1/8	60	15-5/8	16-1/16	59	7-1/2	9-1/2	5/8	5/16	146	163
	C5-20EA-54	C6-20EA-54	54	63	9-9/16	10-1/16	19-1/16	19	57-1/4	56-15/16	65-3/4	16-3/8	16-13/16	65-1/2	9	11	5/8	3/8	160	179
	C5-20EA-60	C6-20EA-60	60	69	9-9/16	10-1/16	21-1/16	21	63	62-11/16	71-1/2	17-1/16	17-1/2	71-1/2	9	11	5/8	3/8	171	192
35°	C5-35EA-18	C6-35EA-18	18	27	8-7/8	9-3/8	7-1/16	7	19-3/4	19-3/16	30-3/8	13-1/8	13-9/16	29	6	8	1/2	3/16	87	94
	C5-35EA-24	C6-35EA-24	24	33	9	9-1/2	9-1/16	9	25	24-1/2	35-11/16	14-7/16	14-13/16	35	6	9-1/2	1/2	5/16	98	109
	C5-35EA-30	C6-35EA-30	30	39	9	9-1/2	11-1/16	11	30-5/16	29-3/4	40-15/16	15-09/16	15-15/16	41	6	9-1/2	1/2	5/16	109	122
	C5-35EA-36	C6-35EA-36	36	45	9	9-1/2	13-1/16	13	35-9/16	35-1/16	46-1/4	16-11/16	17-1/8	47	6	9-1/2	1/2	5/16	120	134
	C5-35EA-42	C6-35EA-42	42	51	9-1/2	10	15-1/16	15	40-1/2	40	51-3/16	18-3/8	18-3/4	53	7-1/2	9-1/2	5/8	5/16	135	151
	C5-35EA-48	C6-35EA-48	48	57	9-1/2	10	17-1/16	17	45-13/16	45-1/4	56-1/2	19-1/2	19-7/8	59	7-1/2	9-1/2	5/8	5/16	146	164
	C5-35EA-54	C6-35EA-54	54	63	9-9/16	10-1/16	19-1/16	19	51-1/16	50-9/16	61-3/4	20-11/16	21-1/8	65-1/2	9	11	5/8	3/8	160	180
	C5-35EA-60	C6-35EA-60	60	69	9-9/16	10-1/16	21-1/16	21	56-3/8	55-13/16	67	21-7/8	22-1/4	71-1/2	9	11	5/8	3/8	171	193
45°	<del>C5-45EA-18</del>	<del>C6-45EA-18</del>	<del>18</del>	<del>27</del>	<del>8-7/8</del>	<del>9-3/8</del>	<del>7-1/16</del>	<del>7</del>	<del>18-3/4</del>	<del>18-1/8</del>	<del>30-11/16</del>	<del>14</del>	<del>14-5/16</del>	<del>29</del>	<del>6</del>	<del>8</del>	<del>1/2</del>	<del>3/16</del>	<del>88</del>	<del>95</del>
	C5-45EA-24	C6-45EA-24	24	33	9	9-1/2	9-1/16	9	23-9/16	22-15/16	35-1/2	15-1/2	15-13/16	35	6	9-1/2	1/2	5/16	100	110
	C5-45EA-30	C6-45EA-30	30	39	9	9-1/2	11-1/16	11	28-7/16	27-3/4	40-5/16	16-15/16	17-1/4	41	6	9-1/2	1/2	5/16	111	123
	C5-45EA-36	C6-45EA-36	36	45	9	9-1/2	13-1/16	13	33-1/4	32-9/16	45-1/4	18-3/16	18-5/8	47	6	9-1/2	1/2	5/16	122	136
	C5-45EA-42	C6-45EA-42	42	51	9-1/2	10	15-1/16	15	37-5/8	37	50-5/16	20-1/4	20-9/16	53	7-1/2	9-1/2	5/8	5/16	137	152
	C5-45EA-48	C6-45EA-48	48	57	9-1/2	10	17-1/16	17	42-1/2	41-13/16	55-1/8	21-11/16	22	59	7-1/2	9-1/2	5/8	5/16	148	166
	C5-45EA-54	C6-45EA-54	54	63	9-9/16	10-1/16	19-1/16	19	47-5/16	46-11/16	59-15/16	23-3/16	23-7/16	65-1/2	9	11	5/8	3/8	162	181
	C5-45EA-60	C6-45EA-60	60	69	9-9/16	10-1/16	21-1/16	21	52-1/8	51-1/2	64-3/4	24-9/16	24-7/8	71-1/2	9	11	5/8	3/8	171	193

\* Also available in bi-directional shoe-activated option. Designated by (BA).

# CEMA C Idlers

## Self-Aligning Return Idler – 4", 5" & 6" Diameter\*\*

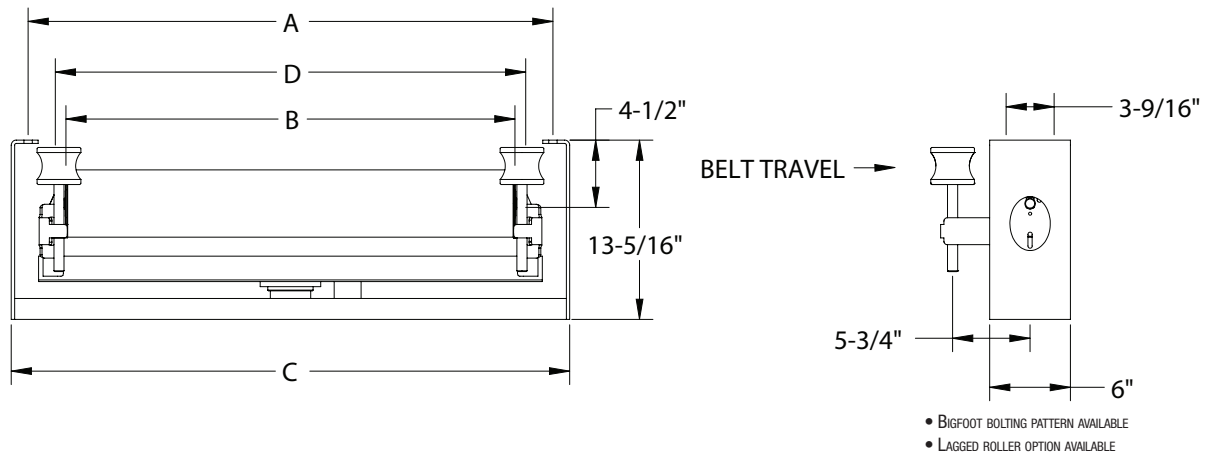

PART NUMBER			BW	A	B	C	D	WT (#)		
4"	5"	6"						4"	5"	6"
C4-RETA-18	C5-RETA-18	C6-RETA-18	18	27	21-3/8	29-1/2	25-5/8	63	69	76
C4-RETA-24	C5-RETA-24	C6-RETA-24	24	33	27-3/8	35-1/2	31-5/8	71	78	87
C4-RETA-30	C5-RETA-30	C6-RETA-30	30	39	33-3/8	41-1/2	37-11/16	82	90	101
C4-RETA-36	C5-RETA-36	C6-RETA-36	36	45	39-3/8	47-1/2	43-5/8	90	99	113
C4-RETA-42	C5-RETA-42	C6-RETA-42	42	51	45-3/8	53-1/2	49-5/8	106	117	132
C4-RETA-48	C5-RETA-48	C6-RETA-48	48	57	51-3/8	59-1/2	55-5/8	116	128	145
C4-RETA-54 ✓	C5-RETA-54 ✓	C6-RETA-54 ✓	54	63	57-3/8	65-1/2	61-5/8	129	142	162
C4-RETA-60 ✓	C5-RETA-60 ✓	C6-RETA-60 ✓	60	69	63-3/8	71-1/2	67-5/8	139	153	175

CEMA C

# CEMA C Idlers

## Feeder / Picking Troughing Idlers – 4", 5", & 6" Diameter

CEMA C

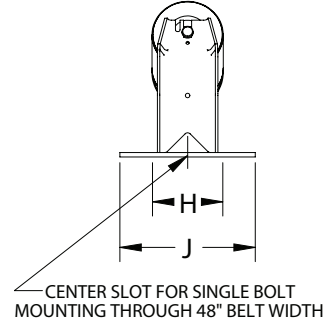
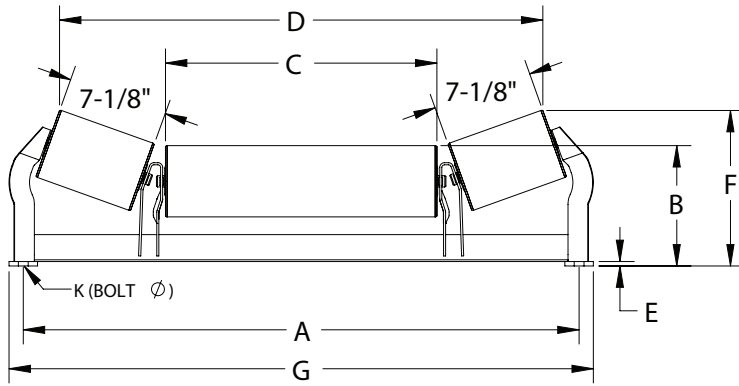

	6" PART NUMBER	BW*	A	B	C	D	E	F	G	H**	J	K	WT (#)
4"	C4-20P-24	24	33	7-15/16	13	28-1/8	5/16	10-3/8	35	6	9-1/2	5/8	39
	C4-20P-30	30	39	7-15/16	19	34-1/8	5/16	10-7/16	41	6	9-1/2	5/8	47
	C4-20P-36	36	45	7-15/16	25	40	5/16	10-7/16	47	6	9-1/2	5/8	52
	C4-20P-42	42	51	8-5/16	30-3/4	46-1/16	5/16	10-7/16	53	6	9-1/2	5/8	66
	C4-20P-48	48	57	8-5/16	36-3/4	52-1/4	5/16	10-7/16	51-3/4	6	9-1/2	5/8	72
	C4-20P-54	54	63	8-3/4	42-7/16	57-15/16	3/8	11-3/16	65-1/2	9	11	5/8	87
	C4-20P-60	60	69	8-3/4	48-7/16	63-15/16	3/8	11-3/16	71-1/2	9	11	5/8	94
5"	C5-20P-24	24	33	8-7/16	13-1/16	27-13/16	5/16	10-7/8	35	6	9-1/2	5/8	47
	C5-20P-30	30	39	8-7/16	19-1/16	33-7/8	5/16	10-7/8	41	6	9-1/2	5/8	56
	C5-20P-36	36	45	8-7/16	25-1/16	39-7/8	5/16	10-7/8	47	6	9-1/2	5/8	63
	C5-20P-42	42	51	8-13/16	30-13/16	46	5/16	10-15/16	53	6	9-1/2	5/8	77
	C5-20P-48	48	57	8-13/16	36-13/16	52	5/16	10-15/16	59	6	9-1/2	5/8	85
	C5-20P-54	54	63	9-1/4	42-1/2	57-5/8	3/8	11-11/16	65-1/2	9	11	5/8	101
	C5-20P-60	60	69	9-1/4	48-1/2	63-5/8	3/8	11-11/16	71-1/2	9	11	5/8	109
6"	<del>C6-20P-24</del>	<del>24</del>	<del>33</del>	<del>8-15/16</del>	<del>13</del>	<del>27-1/2</del>	<del>5/16</del>	<del>11-3/8</del>	<del>35</del>	<del>6</del>	<del>9-1/2</del>	<del>5/8</del>	<del>56</del>
	C6-20P-30	30	39	8-15/16	19	33-1/2	5/16	11-3/8	41	6	9-1/2	5/8	67
	C6-20P-36	36	45	8-15/16	25	39-1/2	5/16	11-3/8	47	6	9-1/2	5/8	76
	C6-20P-42	42	51	9-5/16	30-13/16	45-3/4	5/16	11-7/16	53	6	9-1/2	5/8	91
	C6-20P-48	48	57	9-5/16	36-13/16	51-3/4	5/16	11-3/8	59	6	9-1/2	5/8	101
	C6-20P-54	54	63	9-3/4	42-9/16	57-5/16	3/8	12-1/8	65-1/2	9	11	5/8	118
	C6-20P-60	60	69	9-3/4	48-9/16	63-5/16	3/8	12-1/8	71-1/2	9	11	5/8	128

\* Belt Width (Reinforcing on 36" BW - 60" BW Impact Frame only, use PI for part number).

\*\* Recommended Bolt Pattern - See page 75 for minimum and maximum dimensions.

Use PCI for part number when requiring impact rolls only in the center.



# CEMA C Idlers

## Troughing Idlers (Unequal Length Rolls) – 4" Diameter

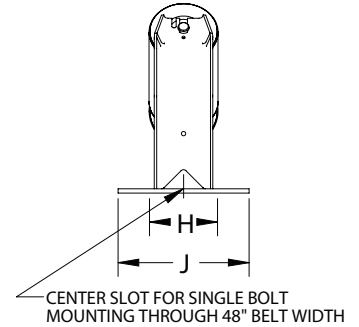
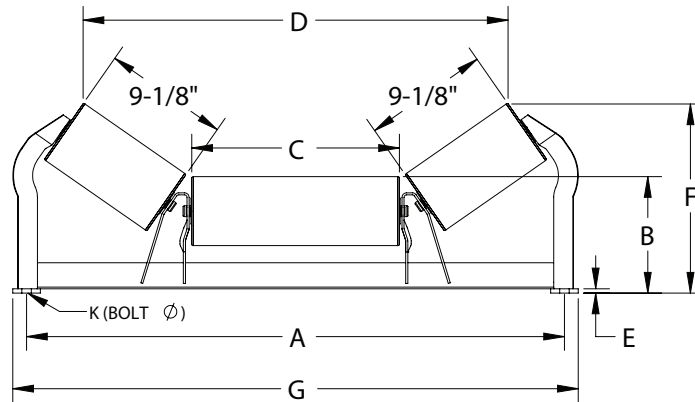

CEMA C

	4" PART NUMBER	BW*	A	B	C	D	E	F	G	H**	J	K	WT (#)
20°	C4-20U-30	30	39	7-15/16	15	33-7/8	5/16	11-1/8	41	6	9-1/2	5/8	47
	C4-20U-36	36	45	7-15/16	21	39-7/8	5/16	11-1/8	47	6	9-1/2	5/8	53
	C4-20U-42	42	51	8-5/16	26-1/2	46	5/16	11-1/8	53	7-1/2	9-1/2	5/8	66
	C4-20U-48	48	57	8-5/16	32-7/16	52	5/16	11-1/8	59	7-1/2	9-1/2	5/8	72
	C4-20U-54	54	63	8-3/4	38	58-1/16	3/8	11-1/4	65-1/2	9	11	5/8	81
	C4-20U-60	60	69	8-3/4	44	64-1/16	3/8	11-1/4	71-1/2	9	11	5/8	94
35°	C4-35U-30	30	39	7-15/16	15-1/16	31-1/4	5/16	13-1/4	41	6	9-1/2	5/8	49
	C4-35U-36	36	45	7-15/16	21	37-1/4	5/16	13-1/4	47	6	9-1/2	5/8	55
	C4-35U-42	42	51	8-5/16	26-1/4	41-5/8	5/16	14-11/16	53	7-1/2	9-1/2	5/8	69
	C4-35U-48	48	57	8-5/16	32-7/16	49-3/8	5/16	13-5/16	59	7-1/2	9-1/2	5/8	74
	C4-35U-54	54	63	8-3/4	38	55-3/8	3/8	13-7/16	65-1/2	9	11	5/8	89
	C4-35U-60	60	69	8-3/4	44	61-3/8	3/8	13-7/16	71-1/2	9	11	5/8	96
45°	C4-45U-30	30	39	7-15/16	15	29-9/16	5/16	14-5/8	41	6	9-1/2	5/8	51
	C4-45U-36	36	45	7-15/16	21	35-9/16	5/16	14-5/8	47	6	9-1/2	5/8	56
	C4-45U-42	42	51	8-5/16	26-1/4	41-5/8	5/16	14-11/16	53	7-1/2	9-1/2	5/8	70
	C4-45U-48	48	57	8-5/16	32-1/4	47-5/8	5/16	14-11/16	59	7-1/2	9-1/2	5/8	76
	C4-45U-54	54	63	8-3/4	37-9/16	53-5/8	3/8	14-13/16	65-1/2	9	11	5/8	90
	C4-45U-60	60	69	8-3/4	43-9/16	59-5/8	3/8	14-13/16	71-1/2	9	11	5/8	97

\* Belt Width (Reinforcing on 36" BW - 60" BW Impact Frame only).

\*\* Recommended Bolt Pattern - See page 73 for minimum and maximum dimensions.  
Note: Also available in rubber cushioned roller. Designated by (U).

# CEMA C Idlers

## Troughing Idlers (Unequal Length Rollers) – 5” & 6” Diameter

CEMA C

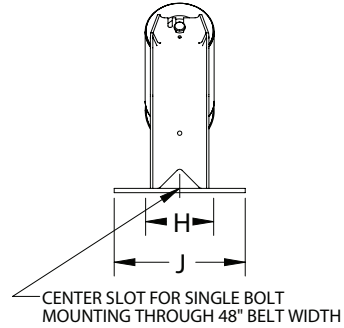
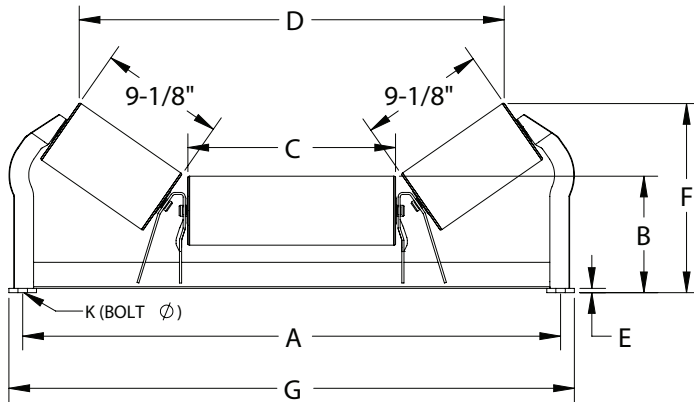

	PART NUMBER		BW	A	B		C		D		E	F		G	H*	J	K	WT (#)	
	5"	6"			5"	6"	5"	6"	5"	6"		5"	6"					5"	6"
20°	C5-20U-30	C6-20U-30	30	39	8-7/16	8-5/16	15-1/16	15	33-5/8	33-1/4	5/16	11-9/16	12-1/16	41	6	9-1/2	5/8	57	68
	C5-20U-36	C6-20U-36	36	45	8-7/16	8-15/16	21-1/16	21	39-5/8	39-1/4	5/16	11-9/16	12-1/16	47	6	9-1/2	5/8	63	77
	C5-20U-42	C6-20U-42	42	51	8-13/16	9-5/16	26-9/16	26-9/16	45-3/4	45-7/16	5/16	11-5/8	12-11/16	53	7-1/2	9-1/2	5/8	78	93
	C5-20U-48	C6-20U-48	48	57	8-13/16	9-5/16	32-9/16	32-9/16	51-3/4	51-7/16	5/16	11-5/8	12-1/8	59	7-1/2	9-1/2	5/8	85	102
	C5-20U-54	C6-20U-54	54	63	9-1/4	9-3/4	38-1/16	38-1/16	57-7/8	57-9/16	3/8	11-3/4	12-3/16	65-1/2	9	11	5/8	101	119
	C5-20U-60	C6-20U-60	60	69	9-1/4	9-3/4	44-1/16	44-1/16	63-7/8	63-9/16	3/8	11-3/4	12-3/16	71-1/2	9	11	5/8	109	129
35°	C5-35U-30	C6-35U-30	30	39	8-7/16	8-15/16	15-1/16	15	30-3/4	30-3/16	5/16	13-11/16	14-1/16	41	6	9-1/2	5/8	58	70
	C5-35U-36	C6-35U-36	36	45	8-7/16	8-15/16	21-1/16	12	36-3/4	36-3/16	5/16	13-11/16	14-1/16	47	6	9-1/2	5/8	65	79
	C5-35U-42	C6-35U-42	42	51	8-13/16	9-5/16	26-9/16	26-9/16	42-7/8	42-3/8	5/16	13-3/4	14-3/16	53	7-1/2	9-1/2	5/8	80	94
	C5-35U-48	C6-35U-48	48	57	8-13/16	9-5/16	32-9/16	32-9/16	48-7/8	48-3/8	5/16	13-3/4	14-3/16	59	7-1/2	9-1/2	5/8	87	104
	C5-35U-54	C6-35U-54	54	63	9-1/4	9-3/4	38-1/16	38-1/16	54-15/16	54-1/2	3/8	13-15/16	14-5/16	65-1/2	9	11	5/8	103	121
	C5-35U-60	C6-35U-60	60	69	9-1/4	9-3/4	44-1/16	44-1/16	60-15/16	60-1/2	3/8	13-15/16	14-5/16	71-1/2	9	11	5/8	111	131
45°	C5-45U-30	C6-45U-30	30	39	8-7/16	8-15/16	15-1/16	15	28-7/8	28-1/4	5/16	15	15-5/16	41	6	9-1/2	5/8	60	72
	C5-45U-36	C6-45U-36	36	45	8-7/16	8-15/16	21-1/16	21	34-7/8	34-1/4	5/16	15	15-5/16	47	6	9-1/2	5/8	66	80
	C5-45U-42	C6-45U-42	42	51	8-13/16	9-5/16	26-5/16	26-5/16	41	40-3/8	5/16	15-1/8	15-7/16	53	7-1/2	9-1/2	5/8	81	96
	C5-45U-48	C6-45U-48	48	57	8-13/16	9-5/16	32-5/16	32-5/16	47	46-3/8	5/16	15-1/8	15-7/16	59	7-1/2	9-1/2	5/8	89	105
	C5-45U-54	C6-45U-54	54	63	9-1/4	9-3/4	37-5/8	37-5/8	53-1/16	52-1/2	3/8	15-1/4	15-9/16	65-1/2	9	11	5/8	104	122
	C5-45U-60	C6-45U-60	60	69	9-1/4	9-3/4	43-5/8	43-5/8	59-1/16	58-1/2	3/8	15-1/4	15-9/16	71-1/2	9	11	5/8	112	132

# CEMA C Idlers

## Offset Center Roll Idler – 4" Diameter

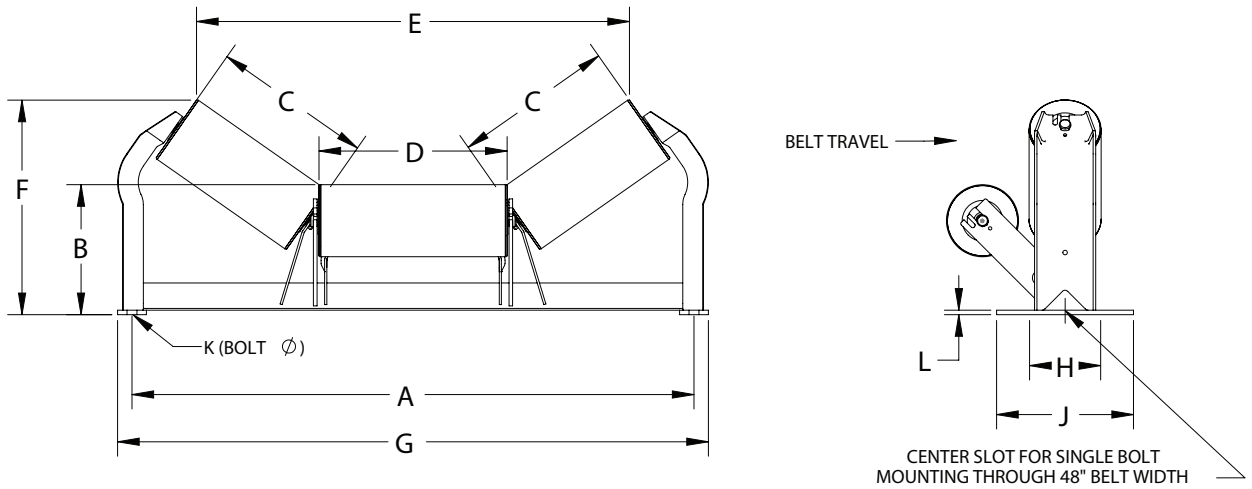

CEMA C

	4" PART NUMBER	BW*	A	B	C	D	E	F	G	H**	J	K	L	WT (#)
20°	C4-20GO-24	24	33	7-7/8	9	11	27-15/16	11-1/8	35	6	9-1/2	5/8	5/16	43
	C4-20GO-30	30	39	7-7/8	11	13	33-11/16	11-13/16	41	6	9-1/2	5/8	5/16	52
	C4-20GO-36	36	45	7-7/8	13	15	39-7/16	12-1/2	47	6	9-1/2	5/8	5/16	57
	C4-20GO-42	42	51	8-5/16	15	17	45-3/16	13-9/16	53	7-1/2	9-1/2	5/8	5/16	72
	C4-20GO-48	48	57	8-5/16	17	19	51	14-1/4	59	7-1/2	9-1/2	5/8	5/16	78
	C4-20GO-54	54	63	8-11/16	19	21	56-3/4	15-5/16	65-1/2	9	11	5/8	3/8	94
	C4-20GO-60	60	69	8-11/16	21	23-5/16	62-1/2	16	71-1/2	9	11	5/8	3/8	101
35°	C4-35GO-24	24	33	7-15/16	9	11	25-5/16	13-5/16	35	6	9-1/2	5/8	5/16	45
	C4-35GO-30	30	39	7-15/16	11	13	30-9/16	14-7/16	41	6	9-1/2	5/8	5/16	54
	C4-35GO-36	36	45	7-15/16	13	15	35-7/8	15-5/8	47	6	9-1/2	5/8	5/16	60
	C4-35GO-42	42	51	8	15	17	41-1/8	17-1/8	53	7-1/2	9-1/2	5/8	5/16	75
	C4-35GO-48	48	57	8	17	19	46-3/8	18-5/16	59	7-1/2	9-1/2	5/8	5/16	82
	C4-35GO-54	54	63	8-7/16	19	21	51-11/16	19-7/8	65-1/2	9	11	5/8	3/8	97
	C4-35GO-60	60	69	8-7/16	21	23-5/16	56-15/16	21	71-1/2	9	11	5/8	3/8	105
45°	C4-45GO-30	30	39	8-11/16	11	13	28-7/16	16-1/16	41	6	9-1/2	5/8	5/16	56
	C4-45GO-36	36	45	9-1/16	13	15	33-1/4	17-1/2	47	6	9-1/2	5/8	5/16	62
	C4-45GO-42	42	51	9-1/16	15	17	38-1/16	19-5/16	53	7-1/2	9-1/2	5/8	5/16	77
	C4-45GO-48	48	57	9-1/16	17	19	42-15/16	20-11/16	59	7-1/2	9-1/2	5/8	5/16	84
	C4-45GO-54	54	63	9-1/2	19	21	47-3/4	22-1/2	65-1/2	9	11	5/8	3/8	100
	C4-45GO-60	60	69	9-1/2	21	23-5/16	52-9/16	23-15/16	71-1/2	9	11	5/8	3/8	108

\* Belt Width (Reinforcing on 36" BW - 60" BW Impact Frame only).

\*\* Recommended Bolt Pattern - See page 73 for minimum and maximum dimensions.

Note: Also available in rubber cushioned roller. Designated by (UI).

# CEMA C Idlers

## Offset Center Roll Idler – 5” & 6” Diameter

CEMA C

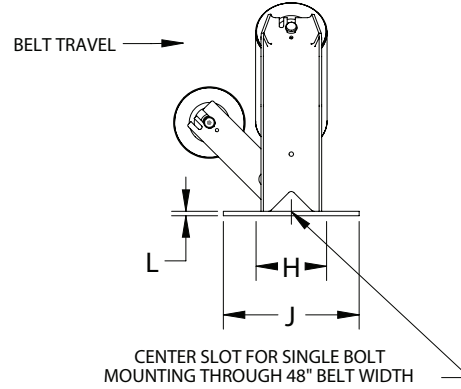
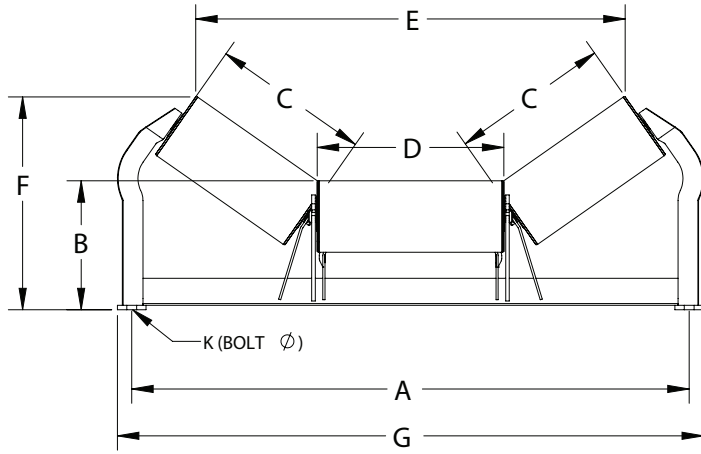

20°

35°

45°

PART NUMBER		BW	A	B		C		D		E		F		G	H*	J	K	L	WT (#)	
5"	6"			5"	6"	5"	6"	5"	6"	5"	6"	5"	6"						5"	6"
C5-20G0-18	C6-20G0-18	18	27	8-1/4	8-3/4	7-1/16	7	9-1/16	9	21-7/8	21-9/16	10-3/4	11-1/4	29	6	8	5/8	5/16	43	52
C5-20G0-24	C6-20G0-24	24	33	8-3/8	8-7/8	9-1/16	9	11-1/16	11	27-5/16	27-5/16	11-9/16	12-1/16	35	6	9-1/2	5/8	5/16	51	62
C5-20G0-30	C6-20G0-30	30	39	8-3/8	8-7/8	11-1/16	11	13-1/16	13	33-7/16	33-1/16	12-5/16	12-3/4	41	6	9-1/2	5/8	5/16	61	73
C5-20G0-36	C6-20G0-36	36	45	8-3/8	8-7/8	13-1/16	13	15-1/16	15	39-3/16	38-7/8	12-15/16	13-7/16	47	6	9-1/2	5/8	5/16	68	83
C5-20G0-42	C6-20G0-42	42	51	8-13/16	9-5/16	15-1/16	15	17-1/16	17	44-15/16	44-5/8	14-1/16	14-1/2	53	7-1/2	9-1/2	5/8	5/16	83	100
C5-20G0-48	C6-20G0-48	48	57	8-13/16	9-5/16	17-1/16	17	19-1/16	19	50-11/16	50-3/8	14-3/4	15-3/16	59	7-1/2	9-1/2	5/8	5/16	92	110
C5-20G0-54	C6-20G0-54	54	63	9-3/16	9-11/16	19-1/16	19	21-1/16	21	56-7/16	56-1/8	15-13/16	16-5/16	65-1/2	9	11	5/8	3/8	108	129
C5-20G0-60	C6-20G0-60	60	69	9-3/16	9-11/16	21-1/16	21	23-3/8	23-3/8	62-3/16	61-7/8	16-1/2	17	71-1/2	9	11	5/8	3/8	117	139
C5-35G0-18	C6-35G0-18	18	27	8-7/8	8-13/16	7-1/16	7	9-1/16	9	19-1/2	18-15/16	12-7/16	12-13/16	29	6	8	1/2	3/16	45	53
C5-35G0-24	C6-35G0-24	24	33	9	8-15/16	9-1/16	9	11-1/16	11	24-3/4	24-1/4	13-11/16	14-1/8	35	6	9-1/2	5/8	5/16	53	64
C5-35G0-30	C6-35G0-30	30	39	9	8-15/16	11-1/16	11	13-1/16	13	30-1/16	29-1/2	14-7/8	15-1/4	41	6	9-1/2	5/8	5/16	63	76
C5-35G0-36	C6-35G0-36	36	45	9-9/16	8-15/16	13-1/16	13	15-1/16	15	35-5/16	34-13/16	16	16-7/16	47	6	9-1/2	5/8	5/16	71	85
C5-35G0-42	C6-35G0-42	42	51	9-1/16	9	15-1/16	15	17-1/16	17	40-5/8	40-1/16	17-9/16	17-15/16	53	7-1/2	9-1/2	5/8	5/16	86	103
C5-35G0-48	C6-35G0-48	48	57	9-1/16	9	17-1/16	17	19-1/16	19	45-7/8	45-3/8	18-11/16	19-1/8	59	7-1/2	9-1/2	5/8	5/16	97	113
C5-35G0-54	C6-35G0-54	54	63	9-7/16	9-7/16	19-1/16	19	21-1/16	21	51-1/8	50-5/8	20-1/4	20-11/16	65-1/2	9	11	5/8	3/8	112	132
C5-35G0-60	C6-35G0-60	60	69	9-7/16	9-7/16	21-1/16	21	23-3/8	23-3/8	56-7/16	55-7/8	21-7/16	21-13/16	71-1/2	9	11	5/8	3/8	115	143
C5-45G0-18	C6-45G0-18	18	27	9-1/16	9-9/16	7-1/16	7	9-1/16	9	18-1/16	17-7/16	13-1/2	13-3/4	29	6	9-1/2	5/8	5/16	46	54
C5-45G0-24	C6-45G0-24	24	33	9-3/16	9-11/16	9-1/16	9	11-1/16	11	22-7/8	22-1/4	15	15-5/16	35	6	9-1/2	5/8	5/16	54	65
C5-45G0-30	C6-45G0-30	30	39	9-3/16	9-11/16	11-1/16	11	13-1/16	13	27-3/4	27-1/8	16-7/16	16-3/4	41	6	9-1/2	5/8	5/16	65	77
C5-45G0-36	C6-45G0-36	36	45	9-3/16	9-11/16	13-1/16	13	15-1/16	15	32-9/16	31-15/16	17-7/8	18-3/16	47	6	9-1/2	5/8	5/16	72	87
C5-45G0-42	C6-45G0-42	42	51	9-9/16	10-1/16	15-1/16	15	17-1/16	17	37-7/16	36-3/4	19-5/8	19-15/16	53	7-1/2	9-1/2	5/8	5/16	89	105
C5-45G0-48	C6-45G0-48	48	57	9-9/16	10-1/16	17-1/16	17	19-1/16	19	42-1/4	41-5/8	21-1/16	21-3/8	59	7-1/2	9-1/2	5/8	5/16	97	116
C5-45G0-54	C6-45G0-54	54	63	10	10-1/2	19-1/16	19	21-1/16	21	47-1/16	46-7/16	22-7/8	23-3/16	65-1/2	9	11	5/8	3/8	115	135
C5-45G0-60	C6-45G0-60	60	69	10	10-1/2	21-1/16	21	23-3/8	23-3/8	51-7/8	51-1/4	24-5/16	25-5/8	71-1/2	9	11	5/8	3/8	124	146

\* Recommended Bolt Pattern - See page 75 for minimum and maximum dimensions.

# CEMA C Idlers

## Channel Mount – 4" & 5" Diameter

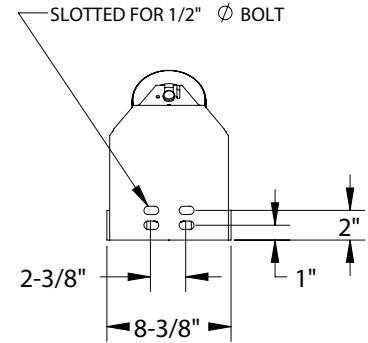
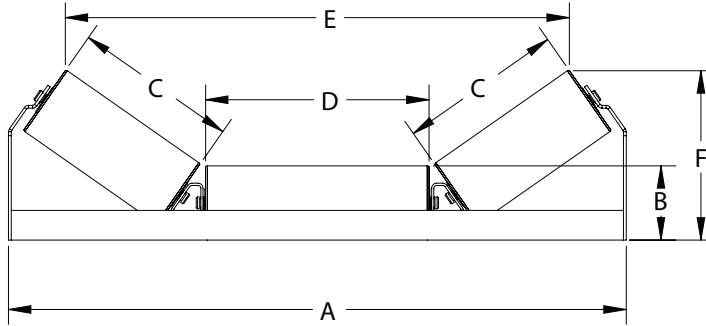

CEMA C

	PART NUMBER		BW*	A	B		C		D		E		F		WT (#)	
	4"	5"			4"	5"	4"	5"	4"	5"	4"	5"	4"	5"	4"	5"
20°	C4-20CM-18	C5-20CM-18	18	23-5/8	4-1/2	5	6	6-1/16	7	7-1/16	20-3/16	19-15/16	6-11/16	7-1/8	33	38
	C4-20CM-20	C5-20CM-20	20	25-5/8	4-1/2	5	7	7-1/16	7	7-1/16	23-3/16	21-7/8	7-1/16	7-1/2	35	41
	C4-20CM-24	C5-20CM-24	24	29-5/8	4-1/2	5	7	7-1/16	11	11-1/16	26-1/16	25-3/4	7-1/16	7-1/2	39	46
	C4-20CM-30	C5-20CM-30	30	35-5/8	4-1/2	5	9	9-1/16	13	13-1/16	31-13/16	31-9/16	7-11/16	8-3/16	46	54
	C4-20CM-36	C5-20CM-36	36	41-5/8	4-1/2	5	11	11-1/16	15	15-1/16	37-9/16	37-5/16	8-3/8	8-7/8	52	62
	C4-20CM-42	C5-20CM-42	42	47-5/8	4-1/2	5	13	13-1/16	17	17-1/16	43-5/16	43-1/16	9-1/16	9-9/16	59	70
	C4-20CM-48	C5-20CM-48	48	53-5/8	4-1/2	5	15	15-1/16	19	19-1/16	49-1/16	48-13/16	9-3/4	10-3/16	65	78
	C4-20CM-54	C5-20CM-54	54	59-5/8	4-1/2	5	17	17-1/16	21-5/16	21-3/8	55-1/8	54-13/16	10-3/8	10-7/8	80	94
	C4-20CM-60	C5-20CM-60	60	65-5/8	4-1/2	5	19	19-1/16	23-5/16	23-3/8	60-7/8	60-5/8	11-1/8	11-9/16	88	103
	35°	C4-35CM-18	C5-35CM-18	18	23-5/8	4-1/2	5	6	6-1/16	7	7-1/16	18-5/16	17-3/4	8-1/8	8-9/16	37
C4-35CM-20		C5-35CM-20	20	25-5/8	4-1/2	5	7	7-1/16	7	7-1/16	19-15/16	19-7/16	8-11/16	9-1/8	40	46
C4-35CM-24		C5-35CM-24	24	29-5/8	4-1/2	5	7	7-1/16	11	11-1/16	23-15/16	23-7/16	8-11/16	9-1/8	44	51
C4-35CM-30		C5-35CM-30	30	35-5/8	4-1/2	5	9	9-1/16	13	13-1/16	29-3/16	28-11/16	9-7/8	10-1/4	51	59
C4-35CM-36		C5-35CM-36	36	41-5/8	4-1/2	5	11	11-1/16	15	15-1/16	34-1/2	33-15/16	11	11-7/16	57	67
C4-35CM-42		C5-35CM-42	42	47-5/8	4-1/2	5	13	13-1/16	17	17-1/16	39-3/4	39-3/16	12-1/8	12-9/16	64	75
C4-35CM-48		C5-35CM-48	48	53-5/8	4-1/2	5	15	15-1/16	19	19-1/16	45-1/16	44-1/2	13-5/16	13-3/4	71	84
C4-35CM-54		C5-35CM-54	54	59-5/8	4-1/2	5	17	17-1/16	21-5/16	21-3/8	50-5/8	50-1/8	14-7/16	14-7/8	87	101
C4-35CM-60		C5-35CM-60	60	65-5/8	4-1/2	5	19	19-1/16	23-5/16	23-3/8	55-13/16	55-5/16	15-9/16	16	95	110

\* Belt Width. 6" wide end stands diameter is available upon request. 27

# CEMA C Idlers

## Low Profile Standard Mount – 4" & 5" Diameter

CEMA C

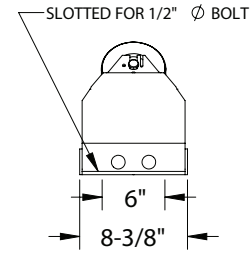
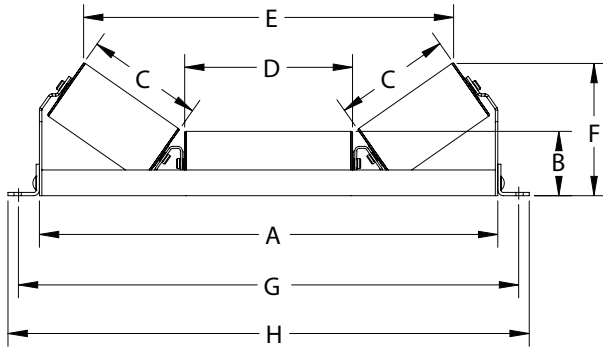

20°

35°

PART NUMBER		BW*	A	B		C		D		E		F		G	H	WT (#)	
4"	5"			4"	5"	4"	5"	4"	5"	4"	5"	4"	5"			4"	5"
C4-20SM-18	C5-20SM-18	18	23-5/8	4-1/2	5	6	6-1/16	7	7-1/16	20-1/4	19-15/16	6-11/16	7-3/16	27	28-1/2	38	43
C4-20SM-20	C5-20SM-20	20	25-5/8	4-1/2	5	7	7-1/16	7	7-1/16	22-1/4	21-15/16	7-1/16	7-1/2	29	30-1/2	40	45
C4-20SM-24	C5-20SM-24	24	29-5/8	4-1/2	5	7	7-1/16	11	11-1/16	26-1/8	25-7/8	7	7-1/2	33	34-1/2	44	50
C4-20SM-30	C5-20SM-30	30	35-5/8	4-1/2	5	9	9-1/16	13	13-1/16	37-7/8	31-5/8	7-11/16	8-3/16	39	40-1/2	51	59
C4-20SM-36	C5-20SM-36	36	41-5/8	4-1/2	5	11	11-1/16	15	15-1/16	37-5/8	37-3/8	8-3/8	8-7/8	45	46-1/2	57	67
C4-20SM-42	C5-20SM-42	42	47-5/8	4-1/2	5	13	13-1/16	17	17-1/16	43-7/16	43-1/8	9-1/16	9-9/16	51	52-1/2	64	75
C4-20SM-48	C5-20SM-48	48	53-5/8	4-1/2	5	15	15-1/16	19	19-1/16	49-3/16	48-7/8	9-3/4	10-1/4	57	58-1/2	70	83
C4-20SM-54	C5-20SM-54	54	59-5/8	4-1/2	5	17	17-1/16	21-5/16	21-3/8	55-3/16	54-15/16	10-7/16	10-7/8	63	64-1/2	85	99
C4-20SM-60	C5-20SM-60	60	65-5/8	4-1/2	5	19	19-1/16	23-5/16	21-3/8	60-15/16	60-5/8	11-1/8	11-5/8	69	70-1/2	93	108
C4-35SM-18	C5-35SM-18	18	23-5/8	4-1/2	5	6	6-1/16	7	7-1/16	18-3/8	17-13/16	8-1/8	8-9/16	27	28-1/2	42	47
C4-35SM-20	C5-35SM-20	20	25-5/8	4-1/2	5	7	7-1/16	7	7-1/16	20	19-1/2	8-3/4	9-1/8	29	30-1/2	44	51
C4-35SM-24	C5-35SM-24	24	29-5/8	4-1/2	5	7	7-1/16	11	11-1/16	24	23-1/2	8-3/4	9-1/8	33	34-1/2	49	55
C4-35SM-30	C5-35SM-30	30	35-5/8	4-1/2	5	9	9-1/16	13	13-1/16	29-1/4	28-3/4	9-7/8	10-1/4	39	40-1/2	56	64
C4-35SM-36	C5-35SM-36	36	41-5/8	4-1/2	5	11	11-1/16	15	15-1/16	34-9/16	34	11	11-7/16	45	46-1/2	63	72
C4-35SM-42	C5-35SM-42	42	47-5/8	4-1/2	5	13	13-1/16	17	17-1/16	39-13/16	39-1/4	12-3/16	12-9/16	51	52-1/2	69	80
C4-35SM-48	C5-35SM-48	48	53-5/8	4-1/2	5	15	15-1/16	19	19-1/16	45-1/16	44-9/16	13-5/16	13-3/4	57	58-1/2	76	89
C4-35SM-54	C5-35SM-54	54	59-5/8	4-1/2	5	17	17-1/16	21-5/16	21-3/8	50-11/16	50-3/16	14-7/16	14-7/8	63	64-1/2	92	106
C4-35SM-60	C5-35SM-60	60	65-5/8	4-1/2	5	19	19-1/16	23-5/16	21-3/8	55-15/16	55-3/8	15-5/8	16	69	70-1/2	100	115

# CEMA C Idlers

## Channel Mount Impact Idlers

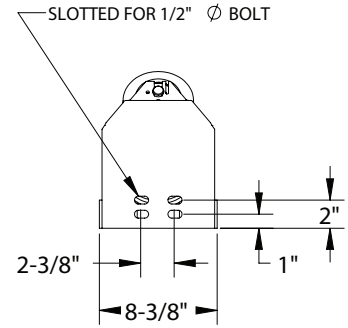
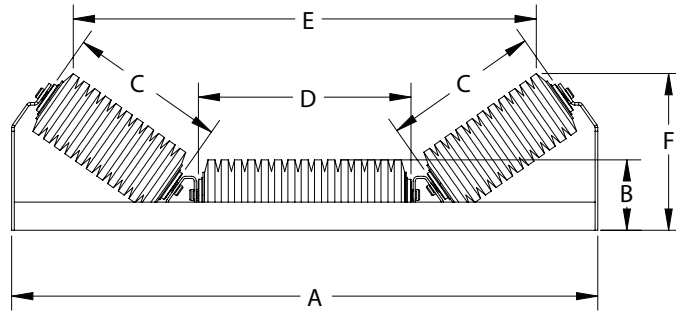

PART NUMBER		BW	A	B		C	D	E		F		WT (#)	
4"	5"			4"	5"			4"	5"	4"	5"	4"	5"
<b>20°</b>													
C4-20CMI-18	C5-20CMI-18	18	23-5/8	4-1/2	5	6-1/8	7-1/8	20-15/16	15-5/8	6-1/2	7	34	39
C4-20CMI-20	C5-20CMI-20	20	25-5/8	4-1/2	5	7-1/8	7-1/8	20-15/16	20-5/8	6-13/16	7-3/8	38	42
C4-20CMI-24	C5-20CMI-24	24	29-5/8	4-1/2	5	7-1/8	11-1/8	24-13/16	24-9/16	6-13/16	7-5/16	43	48
C4-20CMI-30	C5-20CMI-30	30	35-5/8	4-1/2	5	9-1/8	13-1/8	30-9/16	30-5/16	7-1/2	8	51	58
C4-20CMI-36	C5-20CMI-36	36	41-5/8	4-1/2	5	11-1/8	15-1/8	36-3/8	36-1/16	8-3/16	8-11/16	59	67
C4-20CMI-42	C5-20CMI-42	42	47-5/8	4-1/2	5	13-1/8	17-1/8	41-5/8	41-7/8	8-7/8	9-3/8	67	76
C4-20CMI-48	C5-20CMI-48	48	53-5/8	4-1/2	5	15-1/8	19-1/8	47-7/8	47-5/8	9-9/16	10-1/16	76	86
C4-20CMI-54	C5-20CMI-54	54	59-5/8	4-1/2	5	17-1/8	21-7/16	53-7/8	53-5/8	10-1/4	10-11/16	93	104
C4-20CMI-60	C5-20CMI-60	60	65-5/8	4-1/2	5	19-1/8	23-7/16	61	59-3/8	10-15/16	11-7/16	102	115
<b>35°</b>													
C4-35CMI-18	C5-35CMI-18	18	23-5/8	4-1/2	5	6-1/8	7-1/8	17-3/16	16-11/16	7-13/16	8-1/4	39	43
C4-35CMI-20	C5-35CMI-20	20	25-5/8	4-1/2	5	7-1/8	7-1/8	18-7/8	18-5/16	8-3/8	8-13/16	42	47
C4-35CMI-24	C5-35CMI-24	24	29-5/8	4-1/2	5	7-1/8	11-1/8	25-1/8	22-5/16	8-3/8	8-13/16	47	53
C4-35CMI-30	C5-35CMI-30	30	35-5/8	4-1/2	5	9-1/8	13-1/8	28-1/8	27-5/8	9-9/16	10	56	62
C4-35CMI-36	C5-35CMI-36	36	41-5/8	4-1/2	5	11-1/8	15-1/8	33-3/8	32-7/8	10-13/16	11-1/8	65	72
C4-35CMI-42	C5-35CMI-42	42	47-5/8	4-1/2	5	13-1/8	17-1/8	38-5/8	38-1/8	11-7/8	12-5/16	73	82
C4-35CMI-48	C5-35CMI-48	48	53-5/8	4-1/2	5	15-1/8	19-1/8	43-15/16	43-7/16	13	13-7/16	82	92
C4-35CMI-54	C5-35CMI-54	54	59-5/8	4-1/2	5	17-1/8	21-7/16	49-1/2	49	14-1/8	14-9/16	99	111
C4-35CMI-60	C5-35CMI-60	60	65-5/8	4-1/2	5	19-1/8	23-7/16	54-3/4	54-1/4	15-1/4	15-11/16	109	122

# CEMA D Idlers

## Troughing Idlers (Equal Length Rollers) – 5" & 6" Diameter

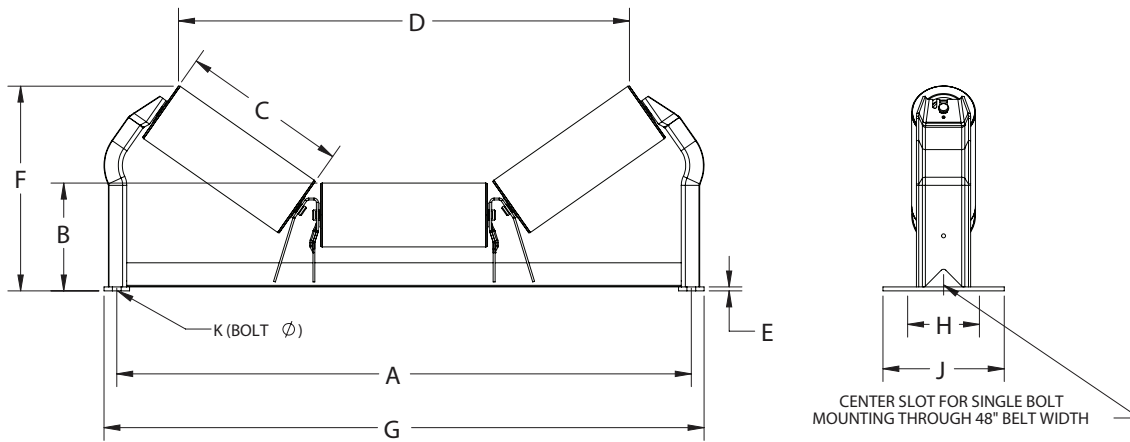

CEMA D

20°

35°

45°

PART NUMBER**		BW	A	B		C	D		E	F		G	H***	J	K	WT (#)	
5"	6"			5"	6"		5"	6"		5"	6"					5"	6"
D5-20E-24	D6-20E-24	24	33	8-1/2	9	9-1/16	27-11/16	27-5/16	5/16	11-11/16	12-1/8	35	6	9-1/2	5/8	54	64
D5-20E-30	D6-20E-30	30	39	8-1/2	9	11-1/16	33-7/16	33-1/8	5/16	12-3/8	12-13/16	41	6	9-1/2	5/8	64	76
D5-20E-36	D6-20E-36	36	45	8-1/2	9	13-1/16	39-3/16	38-7/8	5/16	13-1/16	13-1/2	47	6	9-1/2	5/8	71	86
D5-20E-42	D6-20E-42	42	51	8-7/8	9-3/8	15-1/16	44-15/16	44-5/8	5/16	14-1/8	14-5/8	53	7-1/2	9-1/2	5/8	87	104
D5-20E-48	D6-20E-48	48	57	9-1/4	9-3/4	17-1/16	51	50-11/16	5/16	14-7/8	15-5/16	59	7-1/2	9-1/2	5/8	101	119
D5-20E-54	D6-20E-54	54	63	9-5/16	9-13/16	19-1/16	56-1/2	56-1/8	3/8	15-15/16	16-3/8	65-1/2	9	11	5/8	113	133
D5-20E-60	D6-20E-60	60	69	9-5/16	9-13/16	21-1/16	62-1/4	61-7/8	3/8	16-5/8	17-1/16	71-1/2	9	11	5/8	122	144
D5-20E-72	D6-20E-72	72	81	9-5/16	9-13/16	25-1/16	73-3/4	73-3/8	3/8	18	18-7/16	83-1/2	9	11	5/8	140	166
D5-35E-24	D6-35E-24	24	33	8-1/2	9	9-1/16	24-3/4	24-3/16	5/16	13-3/4	14-3/16	35	6	9-1/2	5/8	56	66
D5-35E-30	D6-35E-30	30	39	8-1/2	9	11-1/16	30	29-7/16	5/16	14-15/16	15-3/8	41	6	9-1/2	5/8	66	78
D5-35E-36	D6-35E-36	36	45	8-1/2	9	13-1/16	35-5/16	34-3/4	5/16	16-1/8	16-1/2	47	6	9-1/2	5/8	74	88
D5-35E-42	D6-35E-42	42	51	8-7/8	9-3/8	15-1/16	40-9/16	40	5/16	17-5/8	18-1/16	53	7-1/2	9-1/2	5/8	90	107
D5-35E-48	D6-35E-48	48	57	9-1/4	9-3/4	17-1/16	46-1/4	45-11/16	5/16	18-15/16	19-5/16	59	7-1/2	9-1/2	5/8	104	122
D5-35E-54	D6-35E-54	54	63	9-5/16	9-13/16	19-1/16	51-1/8	50-9/16	3/8	20-3/8	20-3/4	65-1/2	9	11	5/8	117	137
D5-35E-60	D6-35E-60	60	69	9-5/16	9-13/16	21-1/16	56-7/16	55-13/16	3/8	21-1/2	21-7/8	71-1/2	9	11	5/8	126	148
D5-35E-72	D6-35E-72	72	81	9-5/16	9-13/16	25-1/16	66-15/16	66-3/8	3/8	23-13/16	24-3/16	83-1/2	9	11	5/8	145	171
D5-45E-24	D6-45E-24	24	33	8-1/2	9	9-1/16	22-13/16	22-1/8	5/16	15-1/16	15-3/8	35	6	9-1/2	5/8	57	67
D5-45E-30	D6-45E-30	30	39	8-1/2	9	11-1/16	27-11/16	27	5/16	16-1/2	16-13/16	41	6	9-1/2	5/8	68	80
D5-45E-36	D6-45E-36	36	45	8-1/2	9	13-1/16	32-1/2	31-3/16	5/16	17-15/16	18-1/4	47	6	9-1/2	5/8	76	90
D5-45E-42	D6-45E-42	42	51	8-7/8	9-3/8	15-1/16	37-3/8	36-11/16	5/16	19-11/16	20-1/16	53	7-1/2	9-1/2	5/8	92	109
D5-45E-48	D6-45E-48	48	57	9-1/4	9-3/4	17-1/16	42-9/16	41-7/8	5/16	21-5/16	21-5/8	59	7-1/2	9-1/2	5/8	106	125
D5-45E-54	D6-45E-54	54	63	9-5/16	9-13/16	19-1/16	47	46-5/16	3/8	22-15/16	23-5/16	65-1/2	9	11	5/8	119	139
D5-45E-60	D6-45E-60	60	69	9-5/16	9-13/16	21-1/16	51-7/8	51-3/16	3/8	24-3/8	24-11/16	71-1/2	9	11	5/8	129	151
D5-45E-72	D6-45E-72	72	81	9-5/16	9-13/16	25-1/16	61-1/2	60-13/16	3/8	27-3/16	27-9/16	83-1/2	9	11	5/8	148	174

\*\* 6" roller will be 1/16 shorter

\*\*Add MOX to the end of the part number to replace steel cans with Moxie Rolls

\*\*\* Recommended Bolt Pattern - See page 75 for minimum and maximum dimensions.



# CEMA D Idlers

## Return Idlers – 5" & 6" Diameter

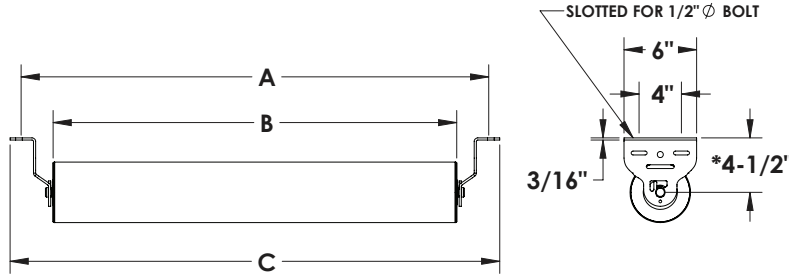

PART NUMBER*		BW	A	B	C	WT (#)**	
5"	6"					5"	6"
D5-RET-18	D6-RET-18	18	27	21-3/8	28-7/16	25	33
D5-RET-20	D6-RET-20	20	29	23-3/8	30-7/16	27	34
D5-RET-24	D6-RET-24	24	33	27-3/8	34-7/16	30	40
D5-RET-30	D6-RET-30	30	39	33-3/8	40-7/16	36	47
D5-RET-36	D6-RET-36	36	45	39-3/8	46-7/16	41	54
D5-RET-42	D6-RET-42	42	51	45-3/8	52-7/16	46	61
D5-RET-48	D6-RET-48	48	57	51-3/8	58-7/16	51	68
D5-RET-54	D6-RET-54	54	63	57-3/8	64-7/16	56	76
D5-RET-60	D6-RET-60	60	69	63-3/8	70-7/16	61	83
D5-RET-72	D6-RET-72	72	81	75-3/8	82-7/16	72	97

CEMA D

## Flat Idlers – 5" & 6" Diameter

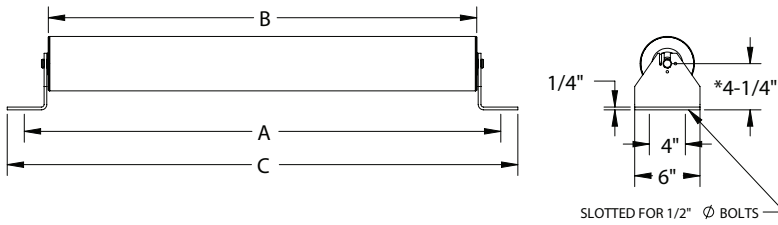

PART NUMBER		BW	A	B	C	WT (#)**	
5"	6"					5"	6"
D5-FLT-18	D6-FLT-18	18	27	21-3/8	28-15/16	28	37
D5-FLT-20	D6-FLT-20	20	29	23-3/8	30-15/16	30	37
D5-FLT-24	D6-FLT-24	24	33	27-3/8	34-15/16	33	43
D5-FLT-30	D6-FLT-30	30	39	33-3/8	40-15/16	38	50
D5-FLT-36	D6-FLT-36	36	45	39-3/8	46-15/16	43	57
D5-FLT-42	D6-FLT-42	42	51	45-3/8	52-15/16	49	64
D5-FLT-48	D6-FLT-48	48	57	51-3/8	58-15/16	54	71
D5-FLT-54	D6-FLT-54	54	63	57-3/8	64-15/16	59	78
D5-FLT-60	D6-FLT-60	60	69	63-3/8	70-15/16	64	85
D5-FLT-72	D6-FLT-72	72	81	75-3/8	82-15/16	74	99

## V-Return Idler – 5" & 6" Diameter

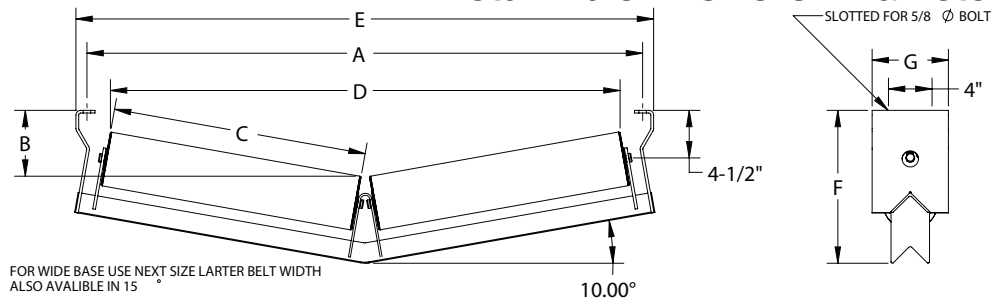

FOR WIDE BASE USE NEXT SIZE LARGER BELT WIDTH  
ALSO AVAILABLE IN 15°

PART NUMBERS		BW	A	B		C	D		E	F	G	WT (#)**	
5"	6"			5"	6"		5"	6"				5"	6"
D5-10RETV-24	D6-10RETV-24	24	33	4-3/8	3-7/8	14-3/8	29	28-9/16	35-1/8	12-3/8	9-1/2	58	68
D5-10RETV-30	D6-10RETV-30	30	39	4-7/8	4-3/8	17	34-5/16	33-7/8	41-1/8	12-7/8	9-1/2	64	76
D5-10RETV-36	D6-10RETV-36	36	45	5-7/16	4-15/16	20-1/2	41-1/16	40-5/8	47-1/8	13-3/8	9-1/2	71	86
D5-10RETV-42	D6-10RETV-42	42	51	5-15/16	5-7/16	23-3/8	46-11/16	46-1/4	53-1/8	14	9-1/2	78	92
D5-10RETV-48	D6-10RETV-48	48	57	6-7/16	6	26-1/2	53	52-9/16	59-1/8	14-1/2	9-1/2	85	103
D5-10RETV-54	D6-10RETV-54	54	63	7	6-1/2	29-1/4	58-5/16	57-7/8	65-1/8	15-3/8	9-1/2	107	127
D5-10RETV-60	D6-10RETV-60	60	69	7-1/2	7-1/16	32-1/2	64-13/16	64-3/8	71-1/8	15-7/8	9-1/2	116	138
D5-10RETV-66	D6-10RETV-66	66	75	8-1/16	7-9/16	35-3/4	71-1/8	70-11/16	77-1/8	16-3/8	9-1/2	125	149
D5-10RETV-72	D6-10RETV-72	72	81	8-9/16	8-1/16	38	75-5/8	75-3/16	83-1/8	17	9-1/2	132	157
D5-10RETV-78	D6-10RETV-78	78	87	9-1/8	8-5/8	41-1/4	82	81-9/16	89-1/8	17-1/2	9 1/2	140	164

\*Add MOX to the end of the part number to replace steel cans with Moxie Rolls  
\*\* All weights include brackets, individual bracket weights are listed on page 73 and 74.

# CEMA D Idlers

## Rubber Cushion Impact Troughing Idler – 5" & 6" Diameter

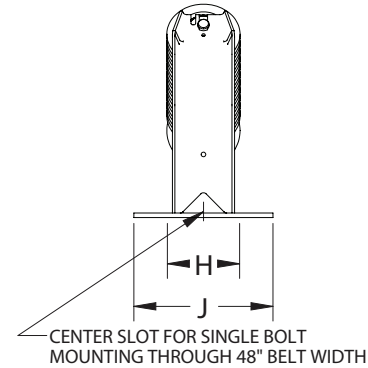
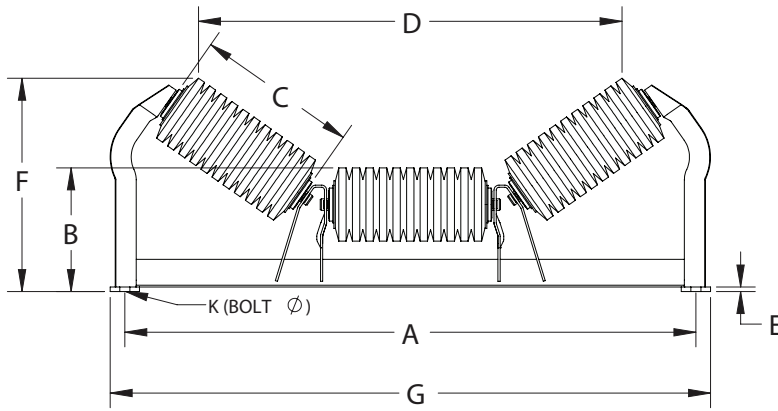

CEMA D

20°

35°

45°

PART NUMBER		BW*	A	B		C	D		E	F		G	H**	J	K	WT (#)	
5"	6"			5"	6"		5"	6"		5"	6"					5"	6"
D5-20EI-24	D6-20EI-24	24	33	8-1/2	9	9-1/8	26-5/16	25-15/16	5/16	11-1/2	11-15/16	35	6	9-1/2	5/8	61	68
D5-20EI-30	D6-20EI-30	30	39	8-1/2	9	11-1/8	32-1/8	31-3/4	5/16	12-3/16	12-11/16	41	6	9-1/2	5/8	74	82
D5-20EI-36	D6-20EI-36	36	45	8-1/2	9	13-1/8	37-7/8	37-1/2	5/16	12-7/8	13-3/8	47	6	9-1/2	5/8	92	94
D5-20EI-42	D6-20EI-42	42	51	8-7/8	9-3/8	15-1/8	43-5/8	43-1/4	5/16	13-15/16	14-7/16	53	7-1/2	9-1/2	5/8	112	123
D5-20EI-48	D6-20EI-48	48	57	9-1/4	9-3/4	17-1/8	49-11/16	49-5/16	5/16	14-11/16	15-3/16	59	7-1/2	9-1/2	5/8	129	141
D5-20EI-54	D6-20EI-54	54	63	9-5/16	9-13/16	19-1/8	55-1/8	54-3/4	3/8	15-3/4	16-3/16	65-1/2	9	11	5/8	146	160
D5-20EI-60	D6-20EI-60	60	69	9-5/16	9-13/16	21-1/8	60-7/8	60-1/2	3/8	16-7/16	16-7/8	71-1/2	9	11	5/8	159	175
D5-20EI-72	D6-20EI-72	72	81	9-5/16	9-13/16	25-1/8	72-3/8	72	3/8	17-13/16	18-1/4	83-1/2	9	11	5/8	183	202
D5-35EI-24	D6-35EI-24	24	33	8-1/2	9	9-1/8	23-1/2	22-15/16	5/16	13-7/16	13-7/8	35	6	9-1/2	5/8	63	70
D5-35EI-30	D6-35EI-30	30	39	8-1/2	9	11-1/8	28-13/16	28-3/16	5/16	14-5/8	15-1/16	41	6	9-1/2	5/8	76	85
D5-35EI-36	D6-35EI-36	36	45	8-1/2	9	13-1/8	34-1/16	33-1/2	5/16	15-13/16	16-3/16	47	6	9-1/2	5/8	95	97
D5-35EI-42	D6-35EI-42	42	51	8-7/8	9-3/8	15-1/8	39-5/16	38-3/4	5/16	17-5/16	17-3/4	53	7-1/2	9-1/2	5/8	116	127
D5-35EI-48	D6-35EI-48	48	57	9-1/4	9-3/4	17-1/8	44-15/16	44-7/16	5/16	18-5/8	19	59	7-1/2	9-1/2	5/8	132	145
D5-35EI-54	D6-35EI-54	54	63	9-5/16	9-13/16	19-1/8	49-7/8	49-5/16	3/8	20	20-7/16	65-1/2	9	11	5/8	150	165
D5-35EI-60	D6-35EI-60	60	69	9-5/16	9-13/16	21-1/8	55-1/8	54-9/16	3/8	21-3/16	21-9/16	71-1/2	9	11	5/8	163	179
D5-35EI-72	D6-35EI-72	72	81	9-5/16	9-13/16	25-1/8	65-11/16	65-1/8	3/8	23-1/2	23-7/8	83-1/2	9	11	5/8	188	207
D5-45EI-24	D6-45EI-24	24	33	8-1/2	9	9-1/8	21-11/16	21	5/16	14-5/8	15	35	6	9-1/2	5/8	64	71
D5-45EI-30	D6-45EI-30	30	39	8-1/2	9	11-1/8	26-9/16	25-7/8	5/16	16-1/16	16-7/16	41	6	9-1/2	5/8	78	86
D5-45EI-36	D6-45EI-36	36	45	8-1/2	9	13-1/8	31-7/16	30-11/16	5/16	17-1/2	17-7/16	47	6	9-1/2	5/8	97	99
D5-45EI-42	D6-45EI-42	42	51	8-7/8	9-3/8	15-1/8	36-3/16	35-1/2	5/16	19-5/16	16-5/8	53	7-1/2	9-1/2	5/8	118	129
D5-45EI-48	D6-45EI-48	48	57	9-1/4	9-3/4	17-1/8	41-7/16	40-3/4	5/16	20-15/16	21-1/4	59	7-1/2	9-1/2	5/8	135	148
D5-45EI-54	D6-45EI-54	54	63	9-5/16	9-13/16	19-1/8	45-7/8	45-3/16	3/8	22-9/16	22-7/8	65-1/2	9	11	5/8	152	167
D5-45EI-60	D6-45EI-60	60	69	9-5/16	9-13/16	21-1/8	50-11/16	50	3/8	23-15/16	24-5/16	71-1/2	9	11	5/8	166	183
D5-45EI-72	D6-45EI-72	72	81	9-5/16	9-13/16	25-1/8	60-3/8	59-5/8	3/8	26-13/16	27-1/8	83-1/2	9	11	5/8	191	211

# CEMA D Idlers

## Rubber Cushion Return Idlers – 5” & 6” Diameter

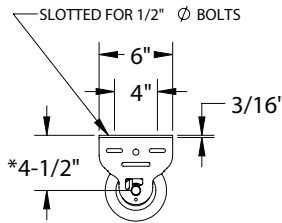
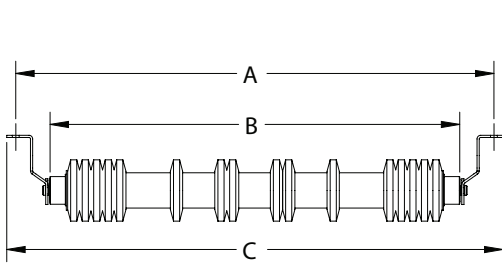

PART NUMBERS		BW	A	B	C	WT (#)*	
5"	6"					5"	6"
D5-RETI-18	D6-RETI-18	18	27	21-7/16	28-7/16	31	34
D5-RETI-20	D6-RETI-20	20	29	23-7/16	30-7/16	34	37
D5-RETI-24	D6-RETI-24	24	33	27-7/16	34-7/16	38	42
D5-RETI-30	D6-RETI-30	30	39	33-7/16	40-7/16	45	49
D5-RETI-36	D6-RETI-36	36	45	39-7/16	46-7/16	52	57
D5-RETI-42	D6-RETI-42	42	51	45-7/16	52-7/16	59	63
D5-RETI-48	D6-RETI-48	48	57	51-7/16	58-7/16	65	70
D5-RETI-54	D6-RETI-54	54	63	57-7/16	64-7/16	72	77
D5-RETI-60	D6-RETI-60	60	69	63-7/16	70-7/16	79	85
D5-RETI-72	D6-RETI-72	72	81	75-7/16	82-7/16	93	99

CEMA D

## Rubber Cushion Flat Idlers – 5” & 6” Diameter

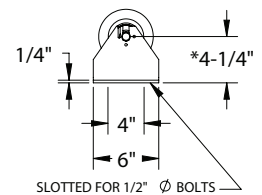
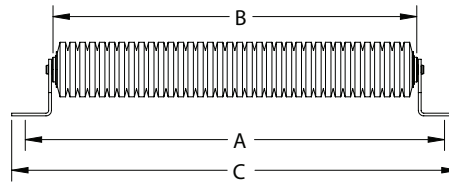

PART NUMBERS		BW	A	B	C	WT (#)*	
5"	6"					5"	6"
D5-FLTI-24	D6-FLTI-24	24	33	27-7/16	34-15/16	45	52
D5-FLTI-30	D6-FLTI-30	30	39	33-7/16	40-15/16	53	62
D5-FLTI-36	D6-FLTI-36	36	45	39-7/16	46-15/16	61	71
D5-FLTI-42	D6-FLTI-42	42	51	45-7/16	52-15/16	69	81
D5-FLTI-48	D6-FLTI-48	48	57	51-7/16	58-15/16	78	92
D5-FLTI-54	D6-FLTI-54	54	63	57-7/16	64-15/16	86	101
D5-FLTI-60	D6-FLTI-60	60	69	63-7/16	70-15/16	94	111
D5-FLTI-72	D6-FLTI-72	72	81	75-7/16	82-15/16	111	131

## Urathon® Return Rolls – 6” Diameter

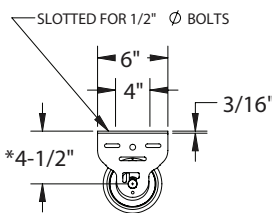
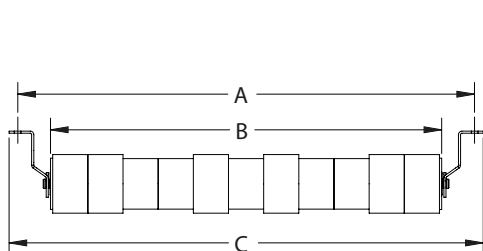

PART NUMBERS		BW	A	B	C	WT (#)*	
5"	6"					5"	6"
D5-RETU-18	D6-RETU-18	18	27	21-3/8	28-7/16	24	31
D5-RETU-24	D6-RETU-24	24	33	27-3/8	34-7/16	28	37
D5-RETU-30	D6-RETU-30	30	39	33-3/8	40-7/16	33	43
D5-RETU-36	D6-RETU-36	36	45	39-3/8	46-7/16	38	49
D5-RETU-42	D6-RETU-42	42	51	45-3/8	52-7/16	42	55
D5-RETU-48	D6-RETU-48	48	57	51-3/8	58-7/16	47	61
D5-RETU-54	D6-RETU-54	54	63	57-3/8	64-7/16	51	67
D5-RETU-60	D6-RETU-60	60	69	63-3/8	70-7/16	56	73
D5-RETU-72	D6-RETU-72	72	81	75-3/8	82-7/16	67	88

Note: Spiral Urathon is only available in 6" diameter. To order Spiral Urathon version add SP after RETU in the part number.

# CEMA D Idlers

## Self-Aligning Troughing Idlers – 5” & 6” Diameter

CEMA D

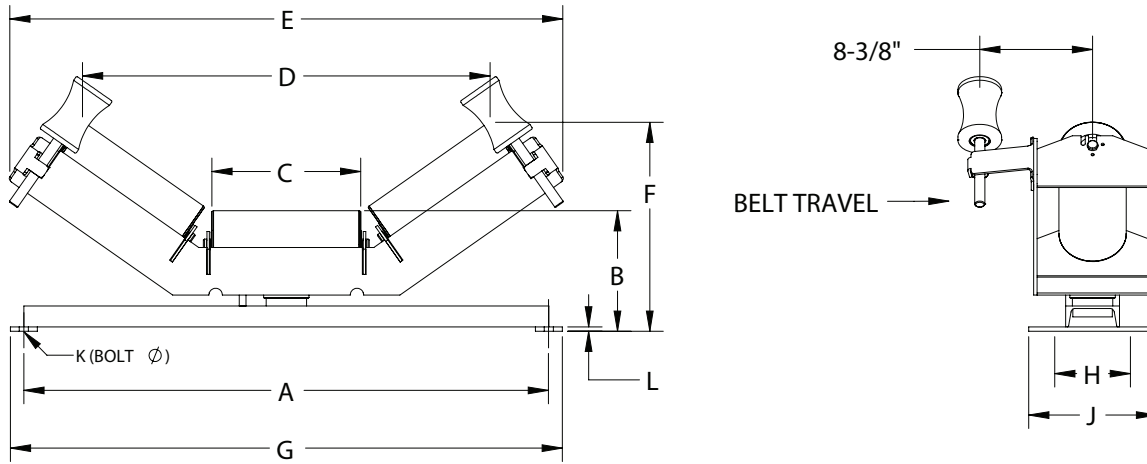

	PART NUMBER		BW	A	B		C	D		E	F		G	H	J	K*	L	WT (#)	
	5"	6"			5"	6"		5"	6"		5"	6"						5"	6"
20°	D5-20EA-24	D6-20EA-24	24	33	9-1/8	9-5/8	9-1/16	28-9/16	28-1/4	36-3/4	12-7/16	12-15/16	35	6	9-1/2	5/8	5/16	104	115
	D5-20EA-30	D6-20EA-30	30	39	9-1/8	9-5/8	11-1/16	34-5/16	34	42-9/16	13-1/8	13-5/8	41	6	9-1/2	5/8	5/16	127	139
	D5-20EA-36	D6-20EA-36	36	45	9-1/8	9-5/8	13-1/16	40-1/16	39-3/4	48-5/16	13-13/16	14-5/16	47	6	9-1/2	5/8	5/16	140	154
	D5-20EA-42	D6-20EA-42	42	51	9-5/8	10-1/8	15-1/16	45-11/16	45-5/16	54-3/16	15	15-5/16	53	6	9-1/2	5/8	5/16	157	173
	D5-20EA-48	D6-20EA-48	48	57	9-5/8	10-1/8	17-1/16	51-7/16	51-1/16	60	15-11/16	16-1/8	59	6	9-1/2	5/8	5/16	170	189
	D5-20EA-54	D6-20EA-54	54	63	9-11/16	10-3/16	19-1/16	57-3/16	56-13/16	65-3/4	18-7/16	16-7/8	65-1/2	6	9-1/2	5/8	3/8	186	207
	D5-20EA-60	D6-20EA-60	60	69	9-11/16	10-3/16	21-1/16	62-15/16	62-5/8	71-1/2	17-1/8	17-7/16	71-1/2	9	11	5/8	3/8	200	222
	D5-20EA-72	D6-20EA-72	72	81	9-11/16	10-3/16	25-1/16	74-1/2	74-7/16	83	18-1/2	18-15/16	83-1/2	9	11	5/8	3/8	227	252
35°	D5-35EA-24	D6-35EA-24	24	33	9-1/8	9-5/8	9-1/16	24-15/16	24-3/8	35-5/8	14-1/2	14-15/16	35	6	9-1/2	5/8	5/16	105	115
	D5-35EA-30	D6-35EA-30	30	39	9-1/8	9-5/8	11-1/16	30-3/16	29-5/8	40-15/16	15-11/16	16-1/16	41	6	9-1/2	5/8	5/16	127	140
	D5-35EA-36	D6-35EA-36	36	45	9-1/8	9-5/8	13-1/16	35-1/2	34-15/16	46-3/16	16-13/16	17-1/16	47	6	9-1/2	5/8	5/16	140	155
	D5-35EA-42	D6-35EA-42	42	51	9-5/8	10-1/8	15-1/16	40-7/16	39-7/8	51-3/4	18-7/16	18-11/16	53	6	9-1/2	5/8	5/16	157	174
	D5-35EA-48	D6-35EA-48	48	57	9-5/8	10-1/8	17-1/16	45-3/4	45-1/8	57	19-7/16	20	59	6	9-1/2	5/8	5/16	171	189
	D5-35EA-54	D6-35EA-54	54	63	9-11/16	10-3/16	19-1/16	51	50-7/16	62-1/4	20-13/16	21-1/16	65-1/2	6	9-1/2	5/8	3/8	187	207
	D5-35EA-60	D6-35EA-60	60	69	9-11/16	10-3/16	21-1/16	56-1/4	55-11/16	67-9/16	21-15/16	22-3/16	71-1/2	9	11	5/8	3/8	201	223
	D5-35EA-72	D6-35EA-72	72	81	9-11/16	10-3/16	25-1/16	66-13/16	66-1/4	78-1/8	24-1/4	24-5/8	83-1/2	9	11	5/8	3/8	228	254
45°	D5-45EA-24	D6-45EA-24	24	33	9-1/8	9-5/8	9-1/16	23-1/2	22-13/16	35-1/2	15-1/2	15-13/16	35	6	9-1/2	5/8	5/16	106	117
	D5-45EA-30	D6-45EA-30	30	39	9-1/8	9-5/8	11-1/16	28-5/16	27-5/8	40-5/16	17	17-5/16	41	6	9-1/2	5/8	5/16	128	141
	D5-45EA-36	D6-45EA-36	36	45	9-1/8	9-5/8	13-1/16	33-1/8	32-7/16	45-3/16	18-7/16	18-3/4	47	6	9-1/2	5/8	5/16	142	156
	D5-45EA-42	D6-45EA-42	42	51	9-5/8	10-1/8	15-1/16	37-9/16	36-7/8	50-5/16	20-5/16	20-1/2	53	6	9-1/2	5/8	5/16	159	175
	D5-45EA-48	D6-45EA-48	48	57	9-5/8	10-1/8	17-1/16	42-3/8	41-11/16	55-1/8	21-3/4	21-15/16	59	6	9-1/2	5/8	5/16	172	191
	D5-45EA-54	D6-45EA-54	54	63	9-11/16	10-3/16	19-1/16	47-3/16	46-1/2	59-15/16	23-3/16	23-7/16	65-1/2	6	9-1/2	5/8	3/8	189	209
	D5-45EA-60	D6-45EA-60	60	69	9-11/16	10-3/16	21-1/16	52-1/16	51-3/8	64-3/4	24-1/2	24-15/16	71-1/2	9	11	5/8	3/8	202	224
	D5-45EA-72	D6-45EA-72	72	81	9-11/16	10-3/16	25-1/16	61-11/16	61	74-7/16	27-7/16	27-13/16	83-1/2	9	11	5/8	3/8	229	255

# CEMA D Idlers

## Self-Aligning Return Idlers – 5" & 6" Diameter\*\*

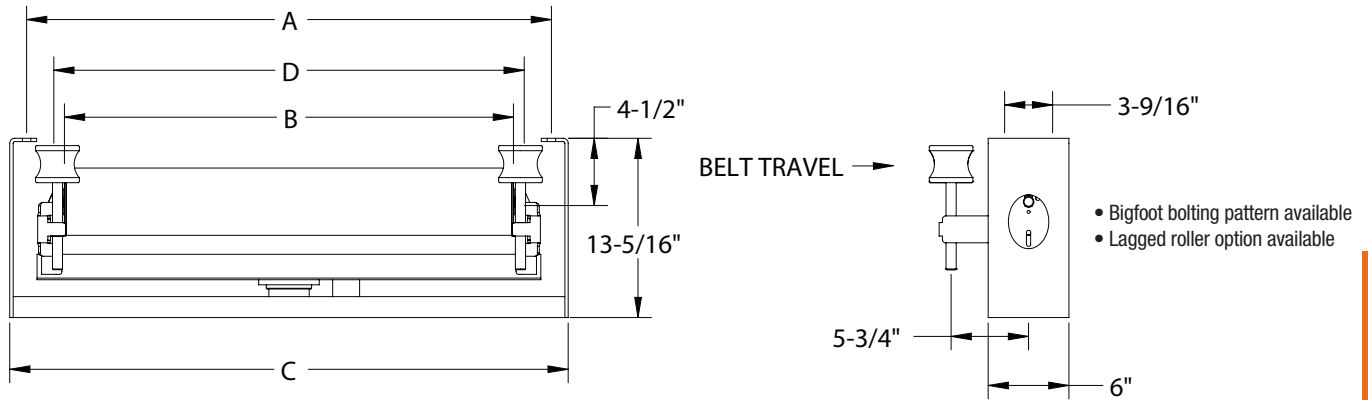

PART NUMBERS		BW	A	B	C	D	WT (#)	
5"	6"						5"	6"
D5-RETA-18	D6-RETA-18	18	27	21-3/8	29-1/2	25-5/8	72	80
D5-RETA-24	D6-RETA-24	24	33	27-3/8	35-1/2	31-5/8	81	91
D5-RETA-30	D6-RETA-30	30	39	33-3/8	41-1/2	37-5/8	94	105
D5-RETA-36	D6-RETA-36	36	45	39-3/8	47-1/2	43-5/8	104	117
D5-RETA-42	D6-RETA-42	42	51	45-3/8	53-1/2	49-5/8	122	137
D5-RETA-48	D6-RETA-48	48	57	51-3/8	59-1/2	55-5/8	133	150
D5-RETA-54	D6-RETA-54	54	63	57-3/8	65-1/2	61-5/8	144	163
D5-RETA-60	D6-RETA-60	60	69	63-3/8	71-1/2	67-5/8	155	176
D5-RETA-72	D6-RETA-72	72	81	75-3/8	83-1/2	79-5/8	177	202

Note: Also available in rubber cushion rollers. Designated by (RETAI).  
 Note: Also available in bi-directional shoe-activated option. Designated by (RETBA).

## Feeder / Picking Troughing Idlers – 5" & 6" Diameter

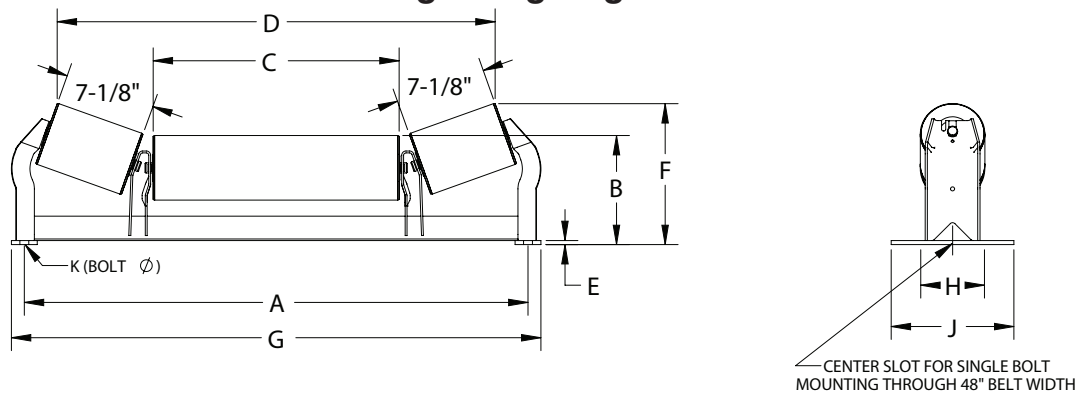

PART NUMBER		BW*	A	B		C	D		E	F		G	H**	J	K	WT (#)	
5"	6"			5"	6"		5"	6"		5"	6"					5"	6"
D5-20P-24	D6-20P-24	24	33	8-1/2	9	13	27-3/4	27-3/8	5/16	11	11-7/16	35	6	9-1/2	5/8	53	63
D5-20P-30	D6-20P-30	30	39	8-1/2	9	19	33-3/4	33-7/16	5/16	11	11-7/16	41	6	9-1/2	5/8	63	75
D5-20P-36	D6-20P-36	36	45	8-1/2	9	25	39-3/4	39-7/16	5/16	11	11-7/16	47	6	9-1/2	5/8	70	84
D5-20P-42	D6-20P-42	42	51	8-7/8	9-3/8	30-3/4	45-15/16	45-5/8	5/16	11-1/16	11-1/2	53	7-1/2	9-1/2	5/8	86	100
D5-20P-48	D6-20P-48	48	57	9-1/4	9-3/4	36-3/4	51-9/16	51-3/16	5/16	11-11/16	12-1/8	59	7-1/2	9-1/2	5/8	98	115
D5-20P-54	D6-20P-54	54	63	9-5/16	9-13/16	42-1/2	57-9/16	57-3/16	3/8	11-3/4	12-3/16	65-1/2	9	11	5/8	110	128
D5-20P-60	D6-20P-60	60	69	9-5/16	9-13/16	48-1/2	63-9/16	63-3/16	3/8	11-3/4	12-3/16	71-1/2	9	11	5/8	118	138
D5-20P-72	D6-20P-72	72	81	9-5/16	9-13/16	60-1/2	75-9/16	75-3/16	3/8	11-3/4	12-3/16	83-1/2	9	11	5/8	136	159

\* Belt Width (Reinforcing on 36" BW - 72" BW frame only).  
 \*\* Recommended Bolt Pattern - See page 75 for minimum and maximum dimensions.  
 Note: Also available in rubber cushion rollers. Designated by PI. For impact roll only in the center use PCI.

# CEMA D Idlers

## Troughing Idlers (Unequal Length Rollers) – 5" & 6" Diameter

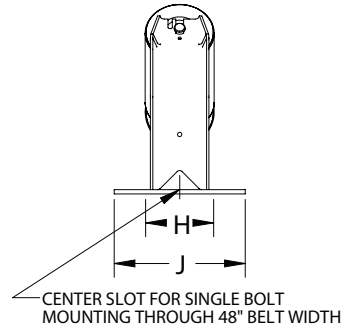
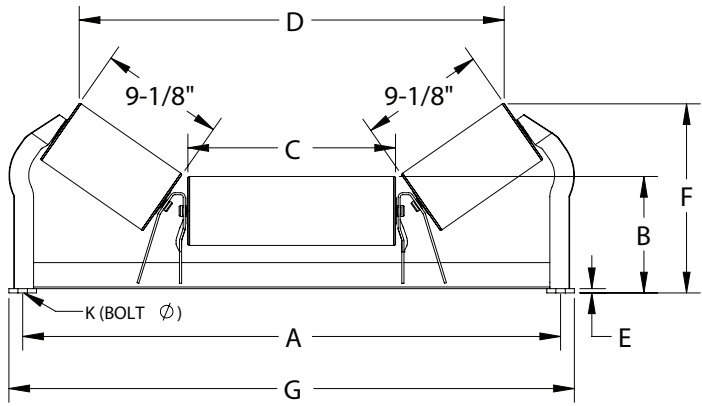

CEMA D

20°

35°

45°

PART NUMBER		BW*	A	B		C	D		D	F		G	H***	J	K	WT	
5"	6"			5"	6"		5"	6"		5"	6"					5"	6"
D5-20U-30	D6-20U-30	30	39	8-1/2	9	15-1/16	33-1/2	33-3/16	5/16	11-11/16	12-1/8	41	6	9-1/2	5/8	63	76
D5-20U-36	D6-20U-36	36	45	8-1/2	9	21-1/16	39-1/2	39-3/16	5/16	11-11/16	12-1/8	47	6	9-1/2	5/8	70	85
D5-20U-42	D6-20U-42	42	51	8-7/8	9-3/8	26-1/2	45-3/16	44-3/4	5/16	12-5/16	12-3/4	53	7-1/2	9-1/2	5/8	86	101
D5-20U-48	D6-20U-48	48	57	9-1/4	9-3/4	32-1/2	51-5/16	50-15/16	5/16	12-3/8	12-13/16	59	7-1/2	9-1/2	5/8	99	116
D5-20U-54	D6-20U-54	54	63	9-5/16	9-13/16	38-1/16	57-5/16	56-15/16	-3/8	12-7/16	12-7/8	65-1/2	9	11	5/8	110	128
D5-20U-60	D6-20U-60	60	69	9-5/16	9-13/16	44-1/16	63-5/16	62-15/16	-3/8	12-7/16	12-7/8	71-1/2	9	11	5/8	119	139
D5-20U-72	D6-20U-72	72	81	9-5/16	9-13/16	56-1/16	75-5/16	74-15/16	-3/8	12-7/16	12-7/8	83-1/2	9	11	5/8	136	160
D5-35U-30	D6-35U-30	30	39	8-1/2	9	15	30-5/8	30-1/16	5/16	13-3/4	14-1/8	41	6	9-1/2	5/8	65	78
D5-35U-36	D6-35U-36	36	45	8-1/2	9	21	36-5/8	36-1/16	5/16	12-3/4	14-1/8	47	6	9-1/2	5/8	72	87
D5-35U-42	D6-35U-42	42	51	8-7/8	9-3/8	56-1/2	42-5/16	41-3/4	5/16	14-3/16	14-9/16	53	7-1/2	9-1/2	5/8	87	103
D5-35U-48	D6-35U-48	48	57	9-1/4	9-3/4	32-1/2	48-1/4	47-11/16	5/16	14-1/2	14-15/16	59	7-1/2	9-1/2	5/8	100	118
D5-35U-54	D6-35U-54	54	63	9-5/16	9-13/16	38-1/16	54-1/4	53-11/16	3/8	14-9/16	15	65-1/2	9	11	5/8	111	130
D5-35U-60	D6-35U-60	60	69	9-5/16	9-13/16	44-1/16	60-1/4	59-11/16	3/8	14-9/16	15	71-1/2	9	11	5/8	120	141
D5-35U-72	D6-35U-72	72	81	9-5/16	9-13/16	56-1/16	72-1/4	71-11/16	3/8	14-9/16	15	83-1/2	9	11	5/8	138	161
D5-45U-30	D6-45U-30	30	39	8-1/2	9	15	28-3/4	28-1/16	5/16	15-1/16	16-3/8	41	6	9-1/2	5/8	67	79
D5-45U-36	D6-45U-36	36	45	8-1/2	9	21	34-3/4	34-1/16	5/16	15-1/16	15-3/8	47	6	9-1/2	5/8	74	88
D5-45U-42	D6-45U-42	42	51	8-7/8	9-3/8	26-1/2	39-1/2	33-13/16	5/16	15-9/16	15-7/8	53	7-1/2	9-1/2	5/8	89	104
D5-45U-48	D6-45U-48	48	57	9-1/4	9-3/4	32-1/2	46-3/4	46-1/16	5/16	15-7/8	13-3/16	59	7-1/2	9-1/2	5/8	102	119
D5-45U-54	D6-45U-54	54	63	9-5/16	9-13/16	38-1/16	52-3/4	52-1/16	3/8	15-15/16	16-1/4	65-1/2	9	11	5/8	113	132
D5-45U-60	D6-45U-60	60	69	9-5/16	9-13/16	44-1/16	58-3/4	58-1/16	3/8	15-15/16	16-1/4	71-1/2	9	11	5/8	122	142
D5-45U-72	D6-45U-72	72	81	9-5/16	9-13/16	56-1/16	70-3/4	70-1/16	3/8	15-15/16	16-1/4	83-1/2	9	11	5/8	140	163

\* Belt Width (Reinforcing on 36" BW - 72" BW Impact Frame only).

\*\* Also available in rubber cushioned roller. Designated by (UI).

\*\*\* Recommended Bolt Pattern - See page 75 for minimum and maximum dimensions.

# CEMA E Idlers

## Troughing Idler (Equal Length Rollers) – 6" & 7" Diameter

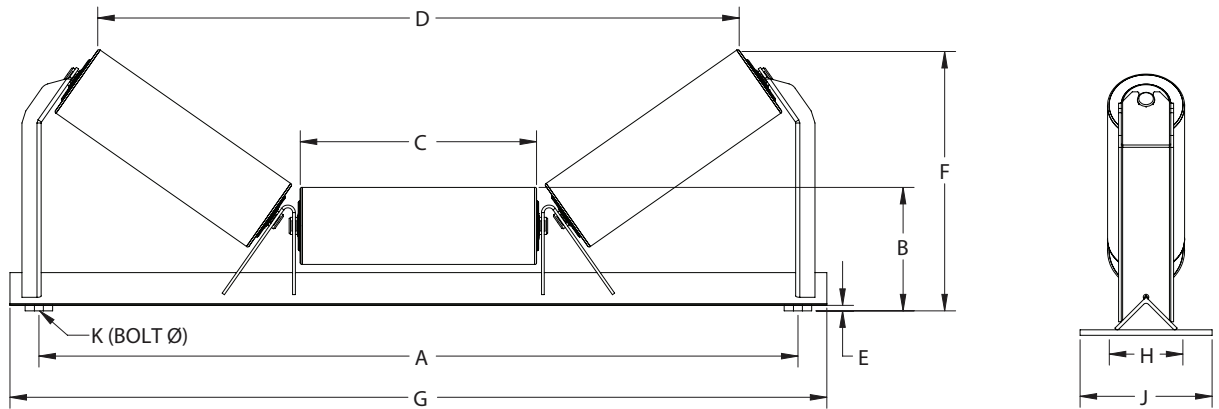

20°

35°

45°

PART NUMBER		BW	A	B		C	D		E	F		G	H	J	K	WT (#)	
6"	7"			6"	7"		6"	7"		6"	7"					6"	7"
E6-20E-36	E7-20E-36	36	45	10-3/4	11-1/4	12-3/4	39-7/8	39-1/2	1/2	15-3/8	15-13/16	49	9-1/2	12	3/4	158	169
E6-20E-42	E7-20E-42	42	51	10-3/4	11-1/4	14-3/4	45-5/8	45-1/4	1/2	16-1/16	16-1/2	55	9-1/2	12	3/4	174	187
E6-20E-48	E7-20E-48	48	57	10-3/4	11-1/4	17-1/2	53-9/16	53-3/16	1/2	17	17-7/16	63	9-1/2	12	3/4	197	212
E6-20E-54	E7-20E-54	54	63	10-3/4	11-1/4	19-1/2	59-5/16	58-15/16	1/2	17-11/16	18-1/8	68-1/2	9-1/2	12	3/4	213	229
E6-20E-60	E7-20E-60	60	69	10-3/4	11-1/4	21-1/2	65-1/16	64-11/16	1/2	18-3/8	18-13/16	74-1/4	9-1/2	12	3/4	229	247
E6-20E-72	E7-20E-72	72	81	11-1/2	12	25-1/2	76-9/16	76-3/16	1/2	20-1/2	20-15/16	86	9-1/2	12	3/4	264	284
E6-20E-84	E7-20E-84	84	93	11-3/4	12-1/4	29-1/2	88-1/16	87-3/4	1/2	22-1/16	22-9/16	97-1/4	12	14	3/4	299	321
E6-20E-96	E7-20E-96	96	105	11-3/4	12-1/4	33-1/2	99-5/8	99-1/4	1/2	23-7/16	23-15/16	109	12	14	3/4	331	357
E6-35E-36	E7-35E-36	36	45	10-3/4	11-1/4	12-3/4	35-13/16	35-1/4	1/2	18-1/4	18-11/16	49	9-1/2	12	3/4	163	174
E6-35E-42	E7-35E-42	42	51	10-3/4	11-1/4	14-3/4	41-1/16	40-1/2	1/2	19-7/16	19-13/16	55	9-1/2	12	3/4	180	192
E6-35E-48	E7-35E-48	48	57	10-3/4	11-1/4	17-1/2	48-5/16	47-3/4	1/2	21	21-7/16	63	9-1/2	12	3/4	203	217
E6-35E-54	E7-35E-54	54	63	10-3/4	11-1/4	19-1/2	53-5/8	53-1/16	1/2	22-1/8	22-9/16	68-1/2	9-1/2	12	3/4	220	235
E6-35E-60	E7-35E-60	60	69	10-3/4	11-1/4	21-1/2	58-7/8	58-5/16	1/2	23-5/16	23-11/16	74-1/4	9-1/2	12	3/4	236	253
E6-35E-72	E7-35E-72	72	81	11-1/2	12	25-1/2	69-7/16	68-7/8	1/2	26-3/8	26-3/4	86	9-1/2	12	3/4	272	292
E6-35E-84	E7-35E-84	84	93	11-3/4	12-1/4	29-1/2	80	79-7/16	1/2	28-7/8	29-5/16	97-1/4	12	14	3/4	308	330
E6-35E-96	E7-35E-96	96	105	11-3/4	12-1/4	33-1/2	90-9/16	89-15/16	1/2	31-3/16	31-9/16	109	12	14	3/4	342	367
E6-45E-36	E7-45E-36	36	45	10-3/4	11-1/4	12-3/4	32-5/16	31-5/8	1/2	19-15/16	20-5/16	49	9-1/2	12	3/4	167	179
E6-45E-42	E7-45E-42	42	51	10-3/4	11-1/4	14-3/4	37-1/8	36-7/16	1/2	21-3/8	21-11/16	55	9-1/2	12	3/4	184	198
E6-45E-48	E7-45E-48	48	57	10-3/4	11-1/4	17-1/2	43-3/4	43-1/16	1/2	23-5/16	23-5/8	63	9-1/2	12	3/4	208	224
E6-45E-54	E7-45E-54	54	63	10-3/4	11-1/4	19-1/2	48-5/8	47-15/16	1/2	24-11/16	26-1/16	68-1/2	9-1/2	12	3/4	225	242
E6-45E-60	E7-45E-60	60	69	10-3/4	11-1/4	21-1/2	53-7/16	52-3/4	1/2	26-1/8	26-1/2	74-1/4	9-1/2	12	3/4	242	261
E6-45E-72	E7-45E-72	72	81	11-1/2	12	25-1/2	63-1/16	62-3/8	1/2	29-11/16	30-1/16	86	9-1/2	12	3/4	279	300
E6-45E-84	E7-45E-84	84	93	11-3/4	12-1/4	29-1/2	72-3/4	72-1/16	1/2	32-3/4	33-1/8	97-1/4	12	14	3/4	315	339
E6-45E-96	E7-45E-96	96	105	11-3/4	12-1/4	33-1/2	82-7/16	81-3/4	1/2	35-9/16	35-15/16	109	12	14	3/4	350	377

CEMA E

# CEMA E Idlers

## Rubber Cushion Impact Troughing Idlers – 6” & 7” Diameter

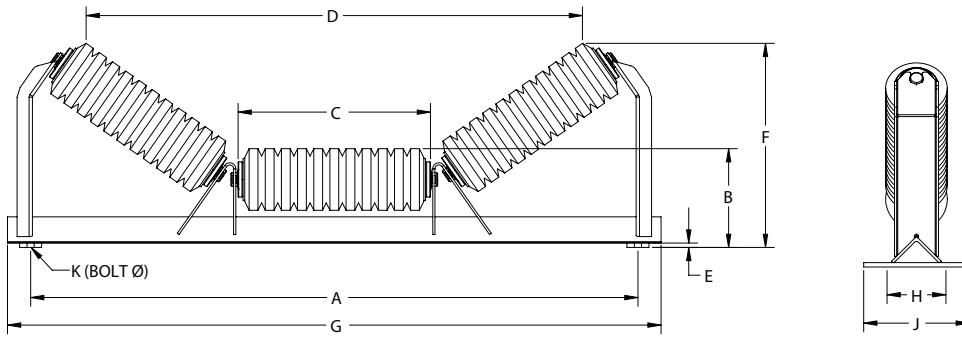

CEMA E

20°

PART NUMBER		BW	A	B		C	D		E	F		G	H*	J	K	WT (#)	
6"	7"			6"	7"		6"	7"		6"	7"					6"	7"
E6-20EI-36	E7-20EI-36	36	45	10-3/4	11-1/4	13-1/8	37-3/4	37-3/8	1/2	15-1/16	15-1/2	49	9-1/2	12	3/4	147	158
E6-20EI-42	E7-20EI-42	42	51	10-3/4	11-1/4	15-1/8	43-1/2	43-1/8	1/2	15-3/4	16-3/16	55	9-1/2	12	3/4	164	177
E6-20EI-48	E7-20EI-48	48	57	10-3/4	11-1/4	17-7/8	51-7/16	51-1/16	1/2	16-11/16	17-1/8	63	9-1/2	12	3/4	188	205
E6-20EI-54	E7-20EI-54	54	63	10-3/4	11-1/4	19-7/8	57-3/16	56-7/8	1/2	17-3/16	17-13/16	68-1/2	9-1/2	12	3/4	205	223
E6-20EI-60	E7-20EI-60	60	69	10-3/4	11-1/4	21-7/8	62-15/16	62-9/16	1/2	18-1/16	18-1/2	74-1/4	9-1/2	12	3/4	221	241
E6-20EI-72	E7-20EI-72	72	81	11-1/2	12	25-7/8	74-7/16	74-1/8	1/2	20-3/16	20-5/8	86	9-1/2	12	3/4	256	280
E6-20EI-84	E7-20EI-84	84	93	11-3/4	12-1/4	29-7/8	85-15/16	85-9/16	1/2	21-13/16	22-1/4	97-1/4	12	14	3/4	290	318
E6-20EI-96	E7-20EI-96	96	105	11-3/4	12-1/4	33-7/8	97-1/2	97-1/8	1/2	23-1/8	23-5/8	109	12	14	3/4	324	355

35°

E6-35EI-36	E7-35EI-36	36	45	10-3/4	11-1/4	13-1/8	33-7/8	33-5/16	1/2	17-3/4	18-3/16	49	9-1/2	12	3/4	153	164
E6-35EI-42	E7-35EI-42	42	51	10-3/4	11-1/4	15-1/8	39-3/16	38-9/16	1/2	18-15/16	19-5/16	55	9-1/2	12	3/4	170	183
E6-35EI-48	E7-35EI-48	48	57	10-3/4	11-1/4	17-7/8	46-7/16	45-7/8	1/2	20-1/2	20-7/8	63	9-1/2	12	3/4	195	211
E6-35EI-54	E7-35EI-54	54	63	10-3/4	11-1/4	19-7/8	54-15/16	51-1/8	1/2	21-1/2	22-1/16	68-1/2	9-1/2	12	3/4	212	230
E6-35EI-60	E7-35EI-60	60	69	10-3/4	11-1/4	21-7/8	56-15/16	56-3/8	1/2	22-13/16	23-3/16	74-1/4	9-1/2	12	3/4	228	249
E6-35EI-72	E7-35EI-72	72	81	11-1/2	12	25-7/8	67-1/2	66-15/16	1/2	25-13/16	26-1/4	86	9-1/2	12	3/4	264	288
E6-35EI-84	E7-35EI-84	84	93	11-3/4	12-1/4	29-7/8	78-1/16	77-1/2	1/2	28-3/8	28-3/4	97-1/4	12	14	3/4	300	328
E6-35EI-96	E7-35EI-96	96	105	11-3/4	12-1/4	33-7/8	88-5/8	88-1/16	1/2	30-11/16	31-1/16	109	12	14	3/4	334	365

45°

E6-45EI-36	E7-45EI-36	36	45	10-3/4	11-1/4	13-1/8	30-5/8	29-7/8	1/2	19-1/4	19-5/8	49	9-1/2	12	3/4	157	168
E6-45EI-42	E7-45EI-42	42	51	10-3/4	11-1/4	15-1/8	35-7/16	36-11/16	1/2	20-11/16	21-1/16	55	9-1/2	12	3/4	174	187
E6-45EI-48	E7-45EI-48	48	57	10-3/4	11-1/4	17-7/8	42-1/16	41-3/8	1/2	22-5/8	23	63	9-1/2	12	3/4	200	216
E6-45EI-54	E7-45EI-54	54	63	10-3/4	11-1/4	19-7/8	45-15/16	46-3/16	1/2	24-1/16	24-7/16	68-1/2	9-1/2	12	3/4	217	235
E6-45EI-60	E7-45EI-60	60	69	10-3/4	11-1/4	21-7/8	51-11/16	51	1/2	25-7/16	25-13/16	74-1/4	9-1/2	12	3/4	234	254
E6-45EI-72	E7-45EI-72	72	81	11-1/2	12	25-7/8	61-3/8	30-11/16	1/2	29-1/16	29-3/8	86	9-1/2	12	3/4	271	295
E6-45EI-84	E7-45EI-84	84	93	11-3/4	12-1/4	29-7/8	71-1/16	70-5/16	1/2	32-1/16	32-7/16	97-1/4	12	14	3/4	308	337
E6-45EI-96	E7-45EI-96	96	105	11-3/4	12-1/4	33-7/8	80-3/4	80	1/2	34-15/16	35-5/16	109	12	14	3/4	342	374

## Rubber Cushion Return Idlers – 6” & 7” Diameter

PART NUMBER		BW	A	B	C	WT (#)**	
6"	7"					6"	7"
E6-RETI-36	E7-RETI-36	36	45	39	48	87	93
E6-RETI-42	E7-RETI-42	42	51	45	54	97	104
E6-RETI-48	E7-RETI-48	48	57	51	60	108	115
E6-RETI-54	E7-RETI-54	54	63	57	66	117	124
E6-RETI-60	E7-RETI-60	60	69	63	72	127	135
E6-RETI-72	E7-RETI-72	72	81	75	84	147	155
E6-RETI-84	E7-RETI-84	84	93	87	96	169	179
E6-RETI-96	E7-RETI-96	96	105	99	108	187	197

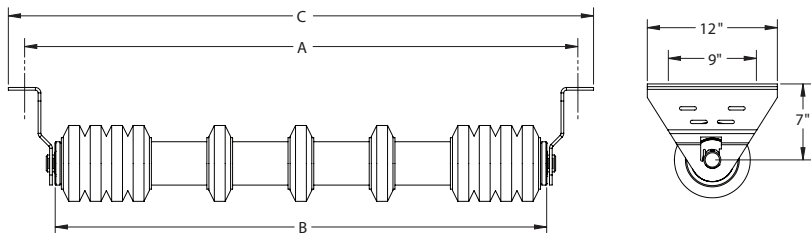



# CEMA E Idlers

## Self-Aligning Troughing Idler – 6" & 7" Diameter

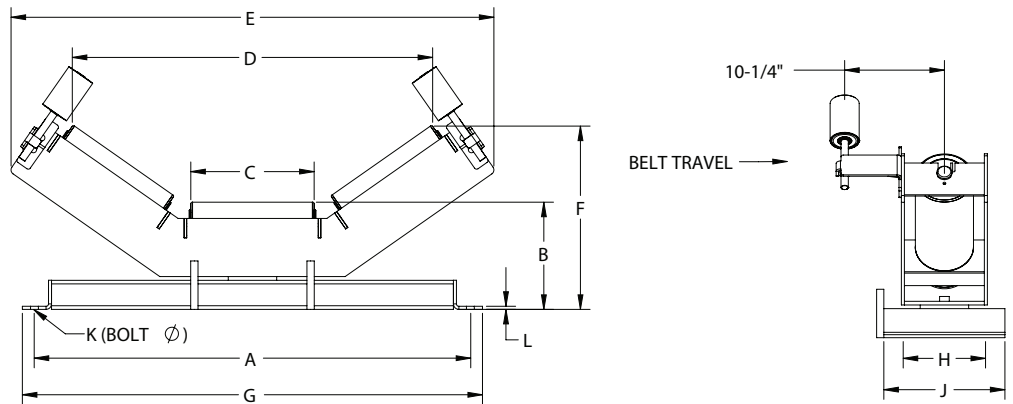

	PART NUMBER		BW	A	B		C		D		E	F		G	H	J	K	L	WT (#)	
	6"	7"			6"	7"	6"	7"	6"	7"		6"	7"						6"	7"
20°	E6-20EA-36	E7-20EA-36	36	45	11-1/16	11-9/16	12-3/4	42-5/8	42-1/4	52-15/16	15-13/16	16-5/16	47-1/2	9-1/2	12-1/2	3/4	5/16	259	270	
	E6-20EA-42	E7-20EA-42	42	51	11-1/16	11-9/16	14-3/4	48-3/8	48	58-3/4	16-1/2	17	53-1/2	9-1/2	12-1/2	3/4	5/16	284	296	
	E6-20EA-48	E7-20EA-48	48	57	11-1/16	11-9/16	17-1/2	56-5/16	55-15/16	66-5/8	17-7/16	17-15/16	59-1/2	9-1/2	12-1/2	3/4	5/16	316	330	
	E6-20EA-54	E7-20EA-54	54	63	11-1/16	11-9/16	19-1/2	61-1/16	61-11/16	72-3/8	18-1/8	18-5/8	65-1/2	9-1/2	12-1/2	3/4	5/16	341	357	
	E6-20EA-60	E7-20EA-60	60	69	11-1/16	11-9/16	21-1/2	67-13/16	67-7/16	78-3/16	18-13/16	19-5/16	71-1/2	9-1/2	12-1/2	3/4	5/16	366	383	
	E6-20EA-72	E7-20EA-72	72	81	12-1/16	12-9/16	25-1/2	79-5/16	79	89-11/16	21-3/16	21-11/16	83-1/2	9-1/2	12-1/2	3/4	5/16	417	436	
	E6-20EA-84	E7-20EA-84	84	93	12-1/16	12-9/16	29-1/2	90-13/16	90-1/2	101-3/16	22-9/16	23	95-1/2	12	15	3/4	5/16	495	517	
	E6-20EA-96	E7-20EA-96	96	105	12-1/16	12-9/16	33-1/2	102-3/8	102	112-11/16	23-15/16	24-3/8	107-1/2	12	15	3/4	5/16	548	573	
	35°	E6-35EA-36	E7-35EA-36	36	45	11-1/16	11-9/16	12-3/4	36-3/4	36-3/16	49-7/8	18-15/16	19-5/8	47-1/2	9-1/2	12-1/2	3/4	5/16	261	272
E6-35EA-42		E7-35EA-42	42	51	11-1/16	11-9/16	14-3/4	42	41-7/16	55-1/8	20-1/16	20-1/2	53-1/2	9-1/2	12-1/2	3/4	5/16	286	299	
E6-35EA-48		E7-35EA-48	48	57	11-1/16	11-9/16	17-1/2	49-1/4	48-11/16	62-3/8	21-5/8	22-1/16	59-1/2	9-1/2	12-1/2	3/4	5/16	318	332	
E6-35EA-54		E7-35EA-54	54	63	11-1/16	11-9/16	19-1/2	54-9/16	54	67-5/8	22-13/16	23-3/16	65-1/2	9-1/2	12-1/2	3/4	5/16	343	359	
E6-35EA-60		E7-35EA-60	60	69	11-1/16	11-9/16	21-1/2	59-13/16	59-1/4	72-15/16	23-15/16	24-3/8	71-1/2	9-1/2	12-1/2	3/4	5/16	369	386	
E6-35EA-72		E7-35EA-72	72	81	12-1/16	12-9/16	25-1/2	70-3/8	69-13/16	83-1/2	27-1/4	27-5/8	83-1/2	9-1/2	12-1/2	3/4	5/16	419	439	
E6-35EA-84		E7-35EA-84	84	93	12-1/16	12-9/16	29-1/2	80-15/16	80-3/8	94-1/16	29-1/2	29-15/16	95-1/2	12	15	3/4	5/16	498	520	
E6-35EA-96		E7-35EA-96	96	105	12-1/16	12-9/16	33-1/2	91-1/2	90-15/16	104-9/16	31-13/16	32-1/4	107-1/2	12	15	3/4	5/16	552	577	
<del>E6-45EA-36</del>		<del>E7-45EA-36</del>	<del>36</del>	<del>45</del>	<del>11-1/16</del>	<del>11-9/16</del>	<del>12-3/4</del>	<del>36-5/16</del>	<del>32-5/8</del>	<del>47-1/8</del>	<del>20-5/8</del>	<del>21</del>	<del>47-1/2</del>	<del>9-1/2</del>	<del>12-1/2</del>	<del>3/4</del>	<del>5/16</del>	<del>259</del>	<del>270</del>	
45°	E6-45EA-42	E7-45EA-42	42	51	11-1/16	11-9/16	14-3/4	37-1/16	37-7/16	51-15/16	22-1/16	22-3/8	53-1/2	9-1/2	12-1/2	3/4	5/16	284	296	
	E6-45EA-48	E7-45EA-48	48	57	11-1/16	11-9/16	17-1/2	44-13/16	44-1/16	58-9/16	24	24-5/16	59-1/2	9-1/2	12-1/2	3/4	5/16	315	330	
	E6-45EA-54	E7-45EA-54	54	63	11-1/16	11-9/16	19-1/2	49-5/8	48-15/16	63-7/16	25-3/8	25-3/4	65-1/2	9-1/2	12-1/2	3/4	5/16	340	356	
	E6-45EA-60	E7-45EA-60	60	69	11-1/16	11-9/16	21-1/2	54-7/16	53-3/4	68-1/4	26-13/16	27-3/16	71-1/2	9-1/2	12-1/2	3/4	5/16	365	382	
	E6-45EA-72	E7-45EA-72	72	81	12-1/16	12-9/16	25-1/2	64-1/8	63-3/8	77-7/8	30-1/16	31	83-1/2	9-1/2	12-1/2	3/4	5/16	415	435	
	E6-45EA-84	E7-45EA-84	84	93	12-1/16	12-9/16	29-1/2	73-3/4	73-1/16	87-9/16	33-1/2	33-13/16	95-1/2	12	15	3/4	5/16	493	515	
	E6-45EA-96	E7-45EA-96	96	105	12-1/16	12-9/16	33-1/2	83-7/16	82-11/16	97-3/16	36-5/16	36-11/16	107-1/2	12	15	3/4	5/16	546	571	

# CEMA E Idlers

## Return Idlers – 6” & 7” Diameter

PART NUMBER		BW	A	B	C	WT (#)*	
6"	7"					6"	7"
E6-RET-30	E7-RET-30	30	39	33	42	85	93
E6-RET-36	E7-RET-36	36	45	39	48	97	106
E6-RET-42	E7-RET-42	42	51	45	54	108	119
E6-RET-48	E7-RET-48	48	57	51	60	120	132
E6-RET-54	E7-RET-54	54	63	57	66	132	145
E6-RET-60	E7-RET-60	60	69	63	72	144	158
E6-RET-72	E7-RET-72	72	81	75	84	167	184
E6-RET-84	E7-RET-84	84	93	87	96	190	211
E6-RET-96	E7-RET-96	96	105	99	108	214	237

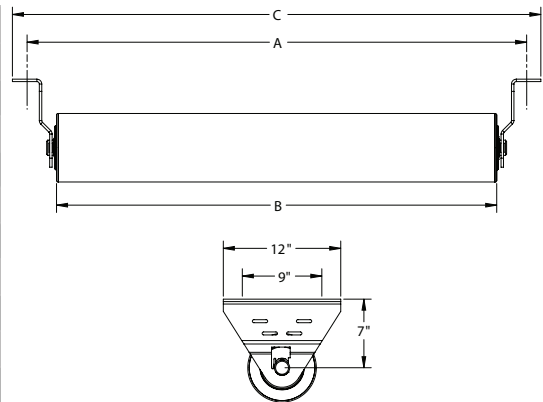

## Rubber Cushion Flat Idlers – 6” & 7” Diameter

PART NUMBER		BW	A	B	C	WT (#)*	
6"	7"					6"	7"
E6-FLTI-36	E7-FLTI-36	36	45	39-3/8	47-1/2	96	108
E6-FLTI-42	E7-FLTI-42	42	51	45-3/8	53-1/2	107	122
E6-FLTI-48	E7-FLTI-48	48	57	51-3/8	59-1/2	119	135
E6-FLTI-54	E7-FLTI-54	54	63	57-3/8	65-1/2	132	150
E6-FLTI-60	E7-FLTI-60	60	69	63-3/8	71-1/2	144	164
E6-FLTI-72	E7-FLTI-72	72	81	75-3/8	83-1/2	167	191
E6-FLTI-84	E7-FLTI-84	84	93	87-3/8	95-1/2	191	218
E6-FLTI-96	E7-FLTI-96	96	105	99-3/8	107-1/2	214	245

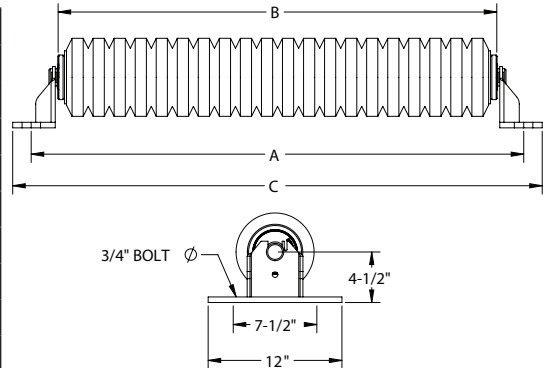

## Flat Idlers – 6” & 7” Diameter

PART NUMBER		BW	A	B	C	WT (#)*	
6"	7"					6"	7"
E6-FLT-30	E7-FLT-30	30	39	33	41-1/2	86	95
E6-FLT-36	E7-FLT-36	36	45	39	47-1/2	98	108
E6-FLT-42	E7-FLT-42	42	51	45	53-1/2	110	121
E6-FLT-48	E7-FLT-48	48	57	51	59-1/2	122	134
E6-FLT-54	E7-FLT-54	54	63	57	65-1/2	133	147
E6-FLT-60	E7-FLT-60	60	69	63	71-1/2	145	160
E6-FLT-72	E7-FLT-72	72	81	75	83-1/2	168	186
E6-FLT-84	E7-FLT-84	84	93	87	95-1/2	192	212
E6-FLT-96	E7-FLT-96	96	105	99	107-1/2	215	238

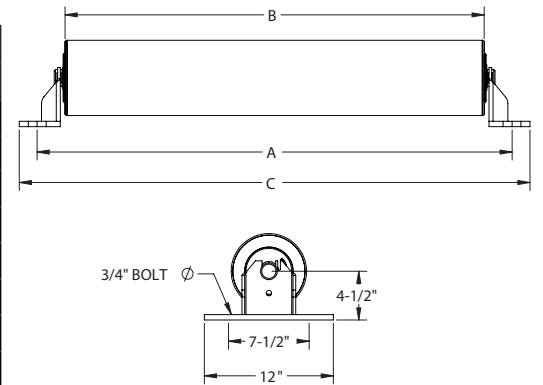

## Return Self-Aligner Idlers – 6” & 7” Diameter

PART NUMBER		BW	A	B	C	D	WT (#)*	
6"	7"						6"	7"
E6-RETA-36	E7-RETA-36	36	45	39	48-1/2	45-1/2	285	294
E6-RETA-42	E7-RETA-42	42	51	45	54-1/2	51-1/2	308	319
E6-RETA-48	E7-RETA-48	48	57	51	60-1/2	57-1/2	331	343
E6-RETA-54	E7-RETA-54	54	63	57	66-1/2	63 1/2	355	368
E6-RETA-60	E7-RETA-60	60	69	63	72-1/2	69-1/2	377	392
E6-RETA-72	E7-RETA-72	72	81	75	84-1/2	81-1/2	423	440
E6-RETA-84	E7-RETA-84	84	93	87	96-1/2	93-1/2	469	489
E6-RETA-96	E7-RETA-96	96	105	99	108-1/2	105-1/2	515	538

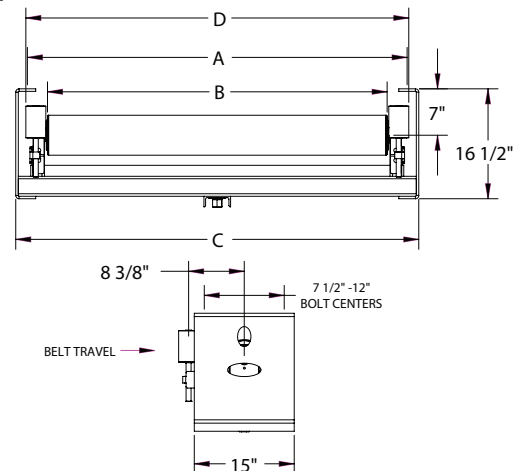

# CEMA E Idlers

## Urathon® Return Roll – 6” & 7” Diameter

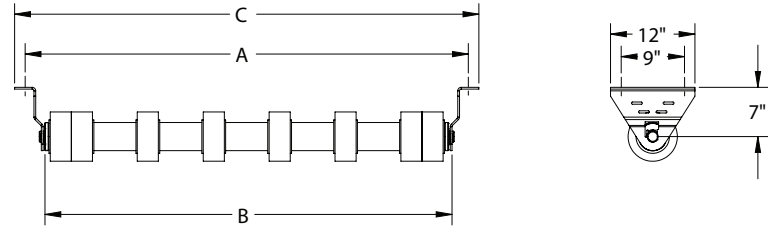

PART NUMBERS		BW	A	B	C	WT (#)	
6"	7"					6"	7"
E6-RETU-36	E7-RETU-36	36	45	39-3/8	48	88	95
E6-RETU-42	E7-RETU-42	42	51	45-3/8	54	99	107
E6-RETU-48	E7-RETU-48	48	57	51-3/8	60	109	116
E6-RETU-54	E7-RETU-54	54	63	57-3/8	66	120	129
E6-RETU-60	E7-RETU-60	60	69	63-3/8	72	131	141
E6-RETU-72	E7-RETU-72	72	81	75-3/8	84	155	168
E6-RETU-84	E7-RETU-84	84	93	87-3/8	96	175	189
E6-RETU-96	E7-RETU-96	96	105	99-3/8	108	196	211

Note: Spiral Urathon is only available in 6” diameter. To order Spiral Urathon version add SP after RETU in the part number.

CEMA E

## V-Return – 6” & 7” Diameter

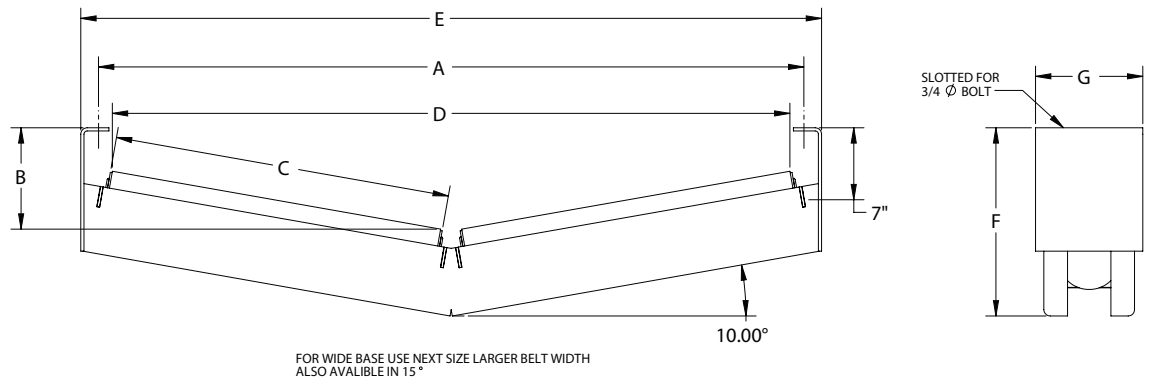

FOR WIDE BASE USE NEXT SIZE LARGER BELT WIDTH  
ALSO AVAILABLE IN 15°

PART NUMBERS		BW	A	B		C	D		E	F	G	WT (#)	
6"	7"			6"	7"		6"	7"				6"	7"
E6-10RETV-36	E7-10RETV-36	36	45	7-3/4	7-1/4	20-1/2	42-3/4	42-9/16	48-1/2	16-5/16	10-1/2	200	211
E6-10RETV-42	E7-10RETV-42	42	51	8-1/4	7-3/4	23-1/2	48-3/4	48-9/16	54-1/2	16-13/16	10-1/2	221	233
E6-10RETV-48	E7-10RETV-48	48	57	8-13/16	8-5/16	26-1/2	54-3/4	54-9/16	60-1/2	17-3/8	10-1/2	242	255
E6-10RETV-54	E7-10RETV-54	54	63	9-5/16	8-13/16	29-1/2	60-3/4	60-9/16	66-1/2	17-7/8	10-1/2	262	277
E6-10RETV-60	E7-10RETV-60	60	69	9-15/16	9-7/16	33	66-3/4	66-9/16	72-1/2	18-7/16	10-1/2	285	301
E6-10RETV-72	E7-10RETV-72	72	81	10-15/16	10-7/16	39	78-3/4	78-9/16	84-1/2	19-1/2	10-1/2	326	345
E6-10RETV-84	E7-10RETV-84	84	93	12	11-1/2	45	90-11/16	90-9/16	96-1/2	20-9/16	10-1/2	368	389
E6-10RETV-96	E7-10RETV-96	96	105	13-1/16	12-9/16	51	102-3/4	102-9/16	108-1/2	21-9/16	10-1/2	409	433

# CEMA F Idlers

## Troughing Idlers (Equal Length Rollers) – 7” Diameter

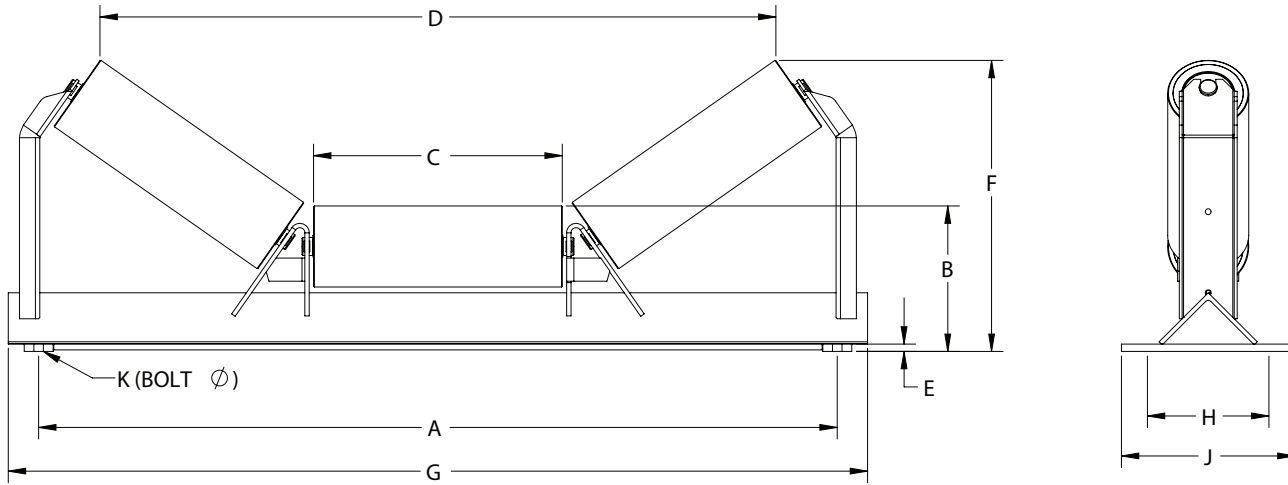

CEMA F

20°

35°

7" PART NUMBER	BW	A	B	C	D	E	F	G	H	J	K	WT (#)
F7-20E-36	36	45	12-9/16	12-3/4	39-1/4	5/8	17-1/8	49-1/2	10-1/2	15	3/4	382
F7-20E-42	42	51	12-9/16	14-3/4	45-1/8	5/8	17-13/16	55	10-1/2	15	3/4	421
F7-20E-48	48	57	12-9/16	17-1/2	53-1/16	5/8	18-3/4	63	10-1/2	15	3/4	471
F7-20E-54	54	63	12-9/16	19-1/2	58-3/4	5/8	19-3/8	68-1/2	10-1/2	15	3/4	510
F7-20E-60	60	69	12-9/16	21-1/2	64-1/2	5/8	20-1/16	74-1/4	10-1/2	15	3/4	548
F7-20E-72	72	81	12-9/16	25-1/2	76-1/8	5/8	21-1/2	86	10-1/2	15	3/4	626
F7-20E-84	84	93	12-9/16	29-1/2	87-5/8	5/8	22-7/8	97-1/2	10-1/2	15	3/4	703
F7-20E-96	96	105	12-9/16	33-1/2	99-1/16	5/8	24-3/16	109	10-1/2	15	3/4	780
F7-35E-36	36	45	12-9/16	12-3/4	35-5/16	5/8	20-1/8	49-1/2	10-1/2	15	3/4	393
F7-35E-42	42	51	12-9/16	14-3/4	40-5/8	5/8	21-1/4	55	10-1/2	15	3/4	432
F7-35E-48	48	57	12-9/16	17-1/2	47-7/8	5/8	22-13/16	63	10-1/2	15	3/4	483
F7-35E-54	54	63	12-9/16	19-1/2	53-1/8	5/8	24	68-1/2	10-1/2	15	3/4	522
F7-35E-60	60	69	12-9/16	21-1/2	58-3/8	5/8	25-1/8	74-1/4	10-1/2	15	3/4	561
F7-35E-72	72	81	12-9/16	25-1/2	68-15/16	5/8	27-7/16	86	10-1/2	15	3/4	639
F7-35E-84	84	93	12-9/16	29-1/2	79-1/2	5/8	29-3/4	97-1/2	10-1/2	15	3/4	717
F7-35E-96	96	105	12-9/16	33-1/2	90-1/16	5/8	32	109	10-1/2	15	3/4	796

Also available in Aligners, Impacts, and Returns

# Component Parts and Replacement Rolls

## Replacement Rolls

CEMA B REPLACEMENT IDLER ROLLS						
BW	Assembled Roll Approx. Length	4" Dia. Roll Part Number	WT (#)	5" Dia. Roll Part Number	WT (#)	
Equal Length Idler Rolls	14 & 16	6-1/16	B4-14	4	B5-14	6
	18	7-1/16	B4-18	5	B5-18	7
	20	7-11/16	B4-20	5	B5-20	7
	24	9-1/16	B4-24	6	B5-24	8
	30	11-1/16	B4-30	7	B5-30	10
	36	13-1/16	B4-36	8	B5-36	11
	42	15-1/16	B4-42	9	B5-42	13
	48	17-1/16	B4-48	10	B5-48	14
Rubber Impact Idler Rolls	18	7-1/16	B4-EI-18	6	B5-EI-18	7
	20	7-11/16	B4-EI-20	7	B5-EI-20	8
	24	9-1/16	B4-EI-24	8	B5-EI-24	9
	30	11-1/16	B4-EI-30	9	B5-EI-30	11
	36	13-1/16	B4-EI-36	11	B5-EI-36	13
	42	15-1/16	B4-EI-42	12	B5-EI-42	15
	48	17-1/16	B4-EI-48	14	B5-EI-48	17

Parts

CEMA C REPLACEMENT IDLER ROLLS								
BW	Assembled Roll Approx. Length	4" Dia. Roll Part Number	WT (#)	5" Dia. Roll Part Number	WT (#)	6" Dia. Roll Part Number	WT (#)	
Equal Length Idler Rolls	18	7-1/16	C4-18	6	C5-18	8	C6-18	10
	24	9-1/16	C4-24	7	C5-24	9	C6-24	13
	30	11-1/16	C4-30	8	C5-30	11	C6-30	15
	36	13-1/16	C4-36	9	C5-36	12	C6-36	17
	42	15-1/16	C4-42	10	C5-42	14	C6-42	19
	48	17-1/16	C4-48	11	C5-48	15	C6-48	21
	54	19-1/16	C4-54	12	C5-54	17	C6-54	24
	60	21-1/16	C4-60	13	C5-60	19	C6-60	26
Rubber Impact Idler Rolls	18	7-1/16	C4-EI-18	7	C5-EI-18	8	C6-EI-18	10
	24	9-1/16	C4-EI-24	8	C5-EI-24	10	C6-EI-24	13
	30	11-1/16	C4-EI-30	10	C5-EI-30	12	C6-EI-30	15
	36	13-1/16	C4-EI-36	12	C5-EI-36	14	C6-EI-36	18
	42	15-1/16	C4-EI-42	13	C5-EI-42	16	C6-EI-42	21
	48	17-1/16	C4-EI-48	15	C5-EI-48	18	C6-EI-48	23
	54	19-1/16	C4-EI-54	17	C5-EI-54	20	C6-EI-54	26
	60	21-1/16	C4-EI-60	18	C5-EI-60	23	C6-EI-60	29

# Component Parts and Replacement Rolls

## Replacement Rolls

CEMA D REPLACEMENT IDLER ROLLS					
BW	Assembled Roll Approx. Length	5" Dia. Roll Part Number	WT (#)	6" Dia. Roll Part Number	WT (#)
18	7-1/16	D5-18	10	D6-18	12
24	9-1/16	D5-24	11	D6-24	15
30	11-1/16	D5-30	13	D6-30	17
36	13-1/16	D5-36	15	D6-36	20
42	15-1/16	D5-42	16	D6-42	22
48	17-1/16	D5-48	18	D6-48	24
54	19-1/16	D5-54	20	D6-54	27
60	21-1/16	D5-60	22	D6-60	29
72	25-1/16	D5-72	25	D6-72	34
<hr/>					
CEMA E REPLACEMENT IDLER ROLLS					
BW	Assembled Roll Approx. Length	6" Dia. Roll Part Number	WT (#)	7" Dia. Roll Part Number	WT (#)
36	12-3/4	E6-36	32	E7-36	36
42	14-3/4	E6-42	36	E7-42	40
48	17-1/2	E6-48	41	E7-48	46
54	19-1/2	E6-54	45	E7-54	51
60	21-1/2	E6-60	49	E7-60	55
72	25-1/2	E6-72	57	E7-72	64
84	29-1/2	E6-84	65	E7-84	72
96	33-1/2	E6-96	73	E7-96	81
<hr/>					
CEMA D REPLACEMENT IDLER ROLLS					
BW	Assembled Roll Approx. Length	5" Dia. Roll Part Number	WT (#)	6" Dia. Roll Part Number	WT (#)
18	7-1/16	D5-EI-18	11	D6-EI-18	13
24	9-1/16	D5-EI-24	14	D6-EI-24	16
30	11-1/16	D5-EI-30	16	D6-EI-30	19
36	13-1/16	D5-EI-36	19	D6-EI-36	22
42	15-1/16	D5-EI-42	22	D6-EI-42	26
48	17-1/16	D5-EI-48	26	D6-EI-48	29
54	19-1/16	D5-EI-54	27	D6-EI-54	32
60	21-1/16	D5-EI-60	30	D6-EI-60	36
72	25-1/16	D5-EI-72	36	D6-EI-72	42

CEMA E REPLACEMENT IDLER ROLLS					
BW	Assembled Roll Approx. Length	6" Dia. Roll Part Number	WT (#)	7" Dia. Roll Part Number	WT (#)
36	12-3/4	E6-36	32	E7-36	36
42	14-3/4	E6-42	36	E7-42	40
48	17-1/2	E6-48	41	E7-48	46
54	19-1/2	E6-54	45	E7-54	51
60	21-1/2	E6-60	49	E7-60	55
72	25-1/2	E6-72	57	E7-72	64
84	29-1/2	E6-84	65	E7-84	72
96	33-1/2	E6-96	73	E7-96	81
<hr/>					
CEMA E REPLACEMENT IDLER ROLLS					
BW	Assembled Roll Approx. Length	6" Dia. Roll Part Number	WT (#)	7" Dia. Roll Part Number	WT (#)
36	12-3/4	E6-EI-36	29	E7-EI-36	29
42	14-3/4	E6-EI-42	33	E7-EI-42	33
48	17-1/2	E6-EI-48	39	E7-EI-48	39
54	19-1/2	E6-EI-54	43	E7-EI-54	43
60	21-1/2	E6-EI-60	47	E7-EI-60	47
72	25-1/2	E6-EI-72	54	E7-EI-72	54
84	29-1/2	E6-EI-84	62	E7-EI-84	62
96	33-1/2	E6-EI-96	70	E7-EI-96	70

## Other Parts

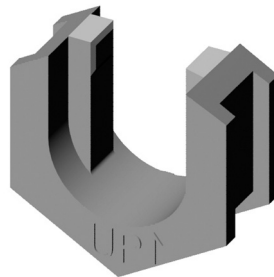

Hex Nut Adaptor

PART NUMBER	DESCRIPTION	PART NUMBER	DESCRIPTION
13-01412	Hex Nut Adapter - Superior	13-10071	CEMA C 35° Center Stand Clip
09-104200	CEMA B Rubber Disc 4" Dia. x 2" I.D.	13-10072	CEMA C 45° Center Stand Clip
09-105200	CEMA B Rubber Disc 5" Dia. x 2" I.D.	13-10073	CEMA D 20° Center Stand Clip
09-104225	CEMA C Rubber Disc 4" Dia. x 2 1/4" I.D.	13-10074	CEMA D 35° Center Stand Clip
09-105225	CEMA C Rubber Disc 5" Dia. x 2 1/4" I.D.	13-10075	CEMA D 45° Center Stand Clip
09-106225	CEMA C Rubber Disc 6" Dia. x 2 1/4" I.D.	13-10068	CEMA B & C End Stand Clip
09-105300	CEMA D Rubber Disc 5" Dia. x 3" I.D.	13-10069	CEMA D End Stand Clip
09-106300	CEMA D Rubber Disc 6" Dia. x 3" I.D.	03-02501	CEMA B Bearing and Seal Kit
09-106400	CEMA E Rubber Disc 6" Dia. x 4" I.D.	03-02502	CEMA C Bearing and Seal Kit
09-107400	CEMA E Rubber Disc 7" Dia. x 4" I.D.	03-02503	CEMA D Bearing and Seal Kit
13-10070	CEMA C 20° Center Stand Clip	03-02499	CEMA E Bearing and Seal Kit

# 81 Series CEMA C Regreaseable Idlers

## Troughing Idlers (Equal Length Rollers) – 4” & 5” Diameter

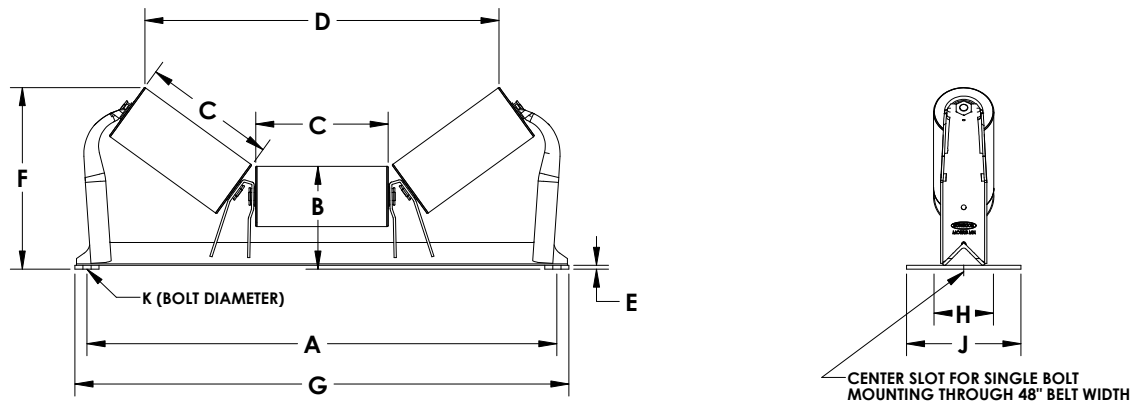

	PART NUMBER		BW	A	B		C	D		E	F		G	H*	J	K	WT (#)			
	4"	5"			4"	5"		4"	5"		4"	5"					4"	5"	4"	5"
	<b>20°</b>	814-20E-18			815-20E-18	18		27	8		8-1/2	7-1/16					21-7/8	21-9/16	1/4	10-1/2
	814-20E-24	815-20E-24	24	33	8	8-1/2	9-1/16	27-5/8	27-5/16	5/16	11-3/16	11-11/16	35	6	9-1/2	5/8	40	44		
	814-20E-30	815-20E-30	30	39	8	8-1/2	11-1/16	33-7/16	33-13/16	5/16	11-13/16	12-3/8	41	6	9-1/2	5/8	46	54		
	814-20E-36	815-20E-36	36	45	8	8-1/2	13-1/16	39-3/16	38-13/16	5/16	12-5/8	13-1/16	47	6	9-1/2	5/8	53	62		
	814-20E-42	815-20E-42	42	51	8-1/2	9	15-1/16	44-15/16	44-9/16	5/16	13-13/16	14-3/16	53	7-1/2	9-1/2	5/8	68	78		
	814-20E-48	815-20E-48	48	57	8-1/2	9	17-1/16	50-11/16	50-3/8	5/16	14-3/8	14-7/8	59	7-1/2	9-1/2	5/8	76	87		
	814-20E-54	815-20E-54	54	63	8-1/2	9	19-1/16	56-7/16	56-1/8	3/8	15-1/8	15-3/8	65-1/2	9	11	5/8	82	96		
	814-20E-60	815-20E-60	60	69	8-1/2	9	21-1/16	62-3/16	61-7/8	3/8	15-3/4	16-3/16	71-1/2	9	11	5/8	88	104		
<b>35°</b>	814-35E-18	815-35E-18	18	27	8	8-1/2	7-1/16	20	19-7/16	1/4	12-1/4	12-3/8	29	6	8	1/2	40	42		
	814-35E-24	815-35E-24	24	33	8	8-1/2	9-1/16	25-5/16	24-11/16	5/16	13-3/8	13-13/16	35	6	9-1/2	5/8	42	47		
	814-35E-30	815-35E-30	30	39	8	8-1/2	11-1/16	30-9/16	30	5/16	14-9/16	14-13/16	41	6	9-1/2	5/8	50	57		
	814-35E-36	815-35E-36	36	45	8	8-1/2	13-1/16	35-13/16	35-1/4	5/16	15-11/16	16-1/8	47	6	9-1/2	5/8	56	64		
	814-35E-42	815-35E-42	42	51	8-1/2	9	15-1/16	41-1/8	40-9/16	5/16	17-5/16	17-11/16	53	7-1/2	9-1/2	5/8	70	82		
	814-35E-48	815-35E-48	48	57	8-1/2	9	17-1/16	46-3/8	45-13/16	5/16	18-7/16	18-7/8	59	7-1/2	9-1/2	5/8	78	90		
	814-35E-54	815-35E-54	54	63	8-1/2	9	19-1/16	51-11/16	51-1/8	3/8	19-5/8	20	65-1/2	9	11	5/8	86	100		
	814-35E-60	815-35E-60	60	69	8-1/2	9	21-1/16	56-15/16	56-3/8	3/8	20-3/4	21-3/16	71-1/2	9	11	5/8	D	107		
<b>45°</b>	814-45E-18	815-45E-18	18	27	8	8-1/2	7-1/16	18-5/8	17-15/16	1/4	13-5/16	13-3/8	29	6	8	1/2	42	43		
	814-45E-24	815-45E-24	24	33	8	8-1/2	9-1/16	23-1/2	22-3/4	5/16	14-11/16	15-1/16	35	6	9-1/2	5/8	44	49		
	814-45E-30	815-45E-30	30	39	8	8-1/2	11-1/16	28-5/16	27-5/8	5/16	16-1/8	16-1/8	41	6	9-1/2	5/8	50	58		
	814-45E-36	815-45E-36	36	45	8	8-1/2	13-1/16	33-1/8	32-7/16	5/16	17-9/16	17-13/16	47	6	9-1/2	5/8	57	65		
	814-45E-42	815-45E-42	42	51	8-1/2	9	15-1/16	37-15/16	37-1/4	5/16	19-7/16	19-1/4	53	7-1/2	9-1/2	5/8	75	85		
	814-45E-48	815-45E-48	48	57	8-1/2	9	17-1/16	42-13/16	42-1/16	5/16	20-13/16	21-3/16	59	7-1/2	9-1/2	5/8	81	92		
	814-45E-54	815-45E-54	54	63	8-1/2	9	19-1/16	47-5/8	46-15/16	3/8	22-1/4	22-3/8	65-1/2	9	11	5/8	87	103		
	814-45E-60	815-45E-60	60	69	8-1/2	9	21-1/16	52-7/16	51-3/4	3/8	23-11/16	24-1/16	71-1/2	9	11	5/8	95	111		

81 Series

# 81 Series CEMA C Regreaseable Idlers

## Troughing Idlers (Equal Length Rollers) – 6” Diameter

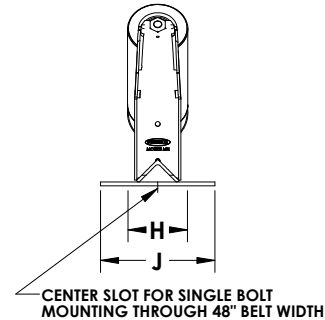
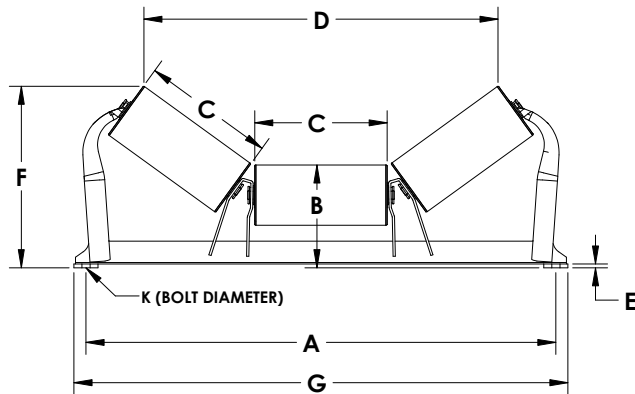

81 Series

	6" PART NUMBER	BW	A	B	C	D	E	F	G	H*	J	K	WT (#)
20°	816-20E-18	18	27	9	7-1/16	21-3/16	1/4	11-7/16	29	6	8	1/2	42
	816-20E-24	24	33	9	9-1/16	26-15/16	5/16	12-1/8	35	6	9-1/2	5/8	49
	816-20E-30	30	39	9	11-1/16	32-3/4	5/16	12-7/8	41	6	9-1/2	5/8	59
	816-20E-36	36	45	9	13-1/16	38-1/2	5/16	13-9/16	47	6	9-1/2	5/8	66
	816-20E-42	42	51	9-1/2	15-1/16	44-1/4	5/16	14-11/16	53	7-1/2	9-1/2	5/8	84
	816-20E-48	48	57	9-1/2	17-1/16	50	5/16	15-3/8	59	7-1/2	9-1/2	5/8	96
	816-20E-54	54	63	9-1/2	19-1/16	55-3/4	3/8	16-1/8	65-1/2	9	11	5/8	114
	816-20E-60	60	69	9-1/2	21-1/16	61-1/2	3/8	16-3/4	71-1/2	9	11	5/8	119
35°	816-35E-18	18	27	9	7-1/16	18-7/8	1/4	13-1/16	29	6	8	1/2	44
	816-35E-24	24	33	9	9-1/16	24-1/8	5/16	14-3/16	35	6	9-1/2	5/8	51
	816-35E-30	30	39	9	11-1/16	29-7/16	5/16	15-3/8	41	6	9-1/2	5/8	61
	816-35E-36	36	45	9	13-1/16	34-11/16	5/16	16-1/2	47	6	9-1/2	5/8	68
	816-35E-42	42	51	9-1/2	15-1/16	40	5/16	18-1/8	53	7-1/2	9-1/2	5/8	86
	816-35E-48	48	57	9-1/2	17-1/16	45-1/4	5/16	19-1/4	59	7-1/2	9-1/2	5/8	98
	816-35E-54	54	63	9-1/2	19-1/16	50-1/2	3/8	20-7/16	65-1/2	9	11	5/8	118
	816-35E-60	60	69	9-1/2	21-1/16	55-13/16	3/8	21-9/16	71-1/2	9	11	5/8	123
45°	816-45E-18	18	27	9	7-1/16	17-1/4	1/4	14	29	6	8	1/2	45
	816-45E-24	24	33	9	9-1/16	22-1/16	5/16	15-7/16	35	6	9-1/2	5/8	53
	816-45E-30	30	39	9	11-1/16	26-7/8	5/16	16-7/8	41	6	9-1/2	5/8	63
	816-45E-36	36	45	9	13-1/16	31-3/4	5/16	18-1/4	47	6	9-1/2	5/8	70
	816-45E-42	42	51	9-1/2	15-1/16	36-9/16	5/16	20-1/8	53	7-1/2	9-1/2	5/8	91
	816-45E-48	48	57	9-1/2	17-1/16	41-3/8	5/16	21-9/16	59	7-1/2	9-1/2	5/8	100
	816-45E-54	54	63	9-1/2	19-1/16	46-3/16	3/8	23	65-1/2	9	11	5/8	122
	816-45E-60	60	69	9-1/2	21-1/16	51	3/8	24-3/8	71-1/2	9	11	5/8	126

\* Recommended Bolt Pattern - See page 75 for minimum and maximum dimensions.



# 81 Series CEMA C Regreaseable Idlers

## Return Idlers – 4", 5", & 6" Diameter

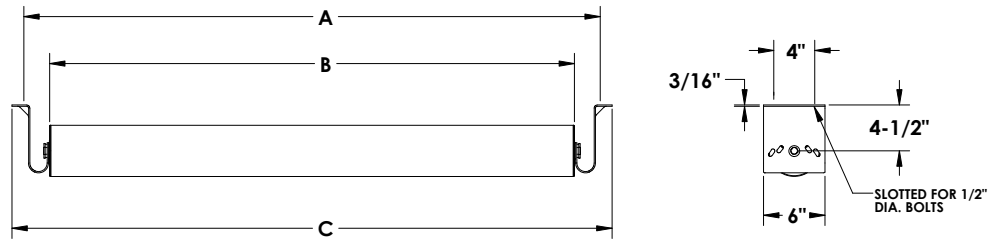

PART NUMBER			BW	A	B	C	WT (#)*		
4"	5"	6"					4"	5"	6"
814-RET-18	815-RET-18	816-RET-18	18	27	21-5/16	28-3/4	19	24	26
814-RET-24	815-RET-24	816-RET-24	24	33	27-5/16	34-3/4	22	29	33
814-RET-30	815-RET-30	816-RET-30	30	39	33-5/16	40-3/4	25	33	37
814-RET-36	815-RET-36	816-RET-36	36	45	39-5/16	46-3/4	31	37	43
814-RET-42	815-RET-42	816-RET-42	42	51	45-5/16	52-3/4	33	40	46
814-RET-48	815-RET-48	816-RET-48	48	57	51-5/16	58-3/4	35	46	52
814-RET-54 ✓	815-RET-54 ✓	816-RET-54 ✓	54	63	57-5/16	64-3/4	40	51	56
814-RET-60 ✓	815-RET-60 ✓	816-RET-60 ✓	60	69	63-5/16	70-3/4	42	55	60

## Flat Idlers – 4", 5", & 6" Diameter

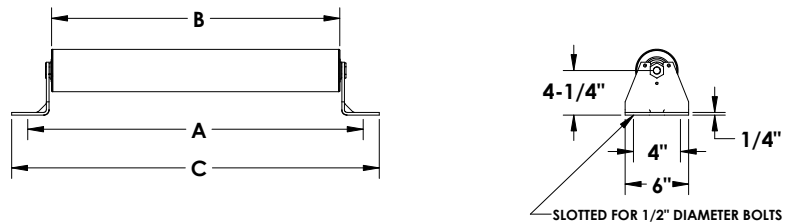

PART NUMBER			BW	A	B	C	WT (#)*		
4"	5"	6"					4"	5"	6"
814-FLT-18	815-FLT-18	816-FLT-18	18	27	21-5/16	28-3/4	19	24	26
814-FLT-24	815-FLT-24	816-FLT-24	24	33	27-5/16	34-3/4	22	29	33
814-FLT-30	815-FLT-30	816-FLT-30	30	39	33-5/16	40-3/4	25	33	37
814-FLT-36	815-FLT-36	816-FLT-36	36	45	39-5/16	46-3/4	31	37	43
814-FLT-42	815-FLT-42	816-FLT-42	42	51	45-5/16	52-3/4	33	40	46
814-FLT-48	815-FLT-48	816-FLT-48	48	57	51-5/16	58-3/4	35	46	52
814-FLT-54 ✓	815-FLT-54 ✓	816-FLT-54 ✓	54	63	57-5/16	64-3/4	40	51	56
814-FLT-60 ✓	815-FLT-60 ✓	816-FLT-60 ✓	60	69	63-5/16	70-3/4	42	55	60

\* All weights include brackets, individual bracket weights are listed on page 74 and 75.

✓ Meets CEMA D specifications.

Note: Return and Flat idlers are supplied with hold down kit for positive locking.

# 81 Series CEMA C Regreaseable Idlers

## Rubber Cushion Impact Troughing Idlers – 4" & 5" Diameter

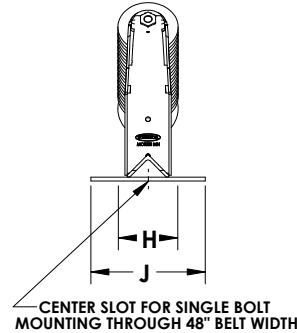
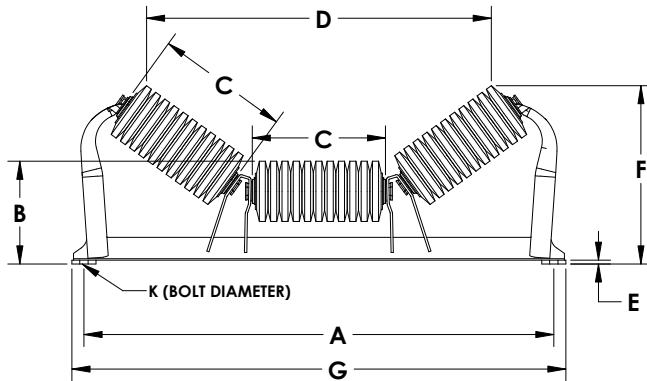

81 Series

	PART NUMBER		BW*	A	B		C	D		E	F		G	H**	J	K	WT (#)	
	4"	5"			4"	5"		4"	5"		4"	5"					4"	5"
20°	814-20EI-18	815-20EI-18	18	27	8	8-1/2	7-1/16	21-3/8	21-1/16	1/4	10-3/8	10-7/8	29	6	8	1/2	40	46
	814-20EI-24	815-20EI-24	24	33	8	8-1/2	9-1/16	27-1/8	26-13/16	5/16	11-1/16	11-9/16	35	6	9-1/2	5/8	47	51
	814-20EI-30	815-20EI-30	30	39	8	8-1/2	11-1/16	32-15/16	32-9/16	5/16	11-11/16	12-1/4	41	6	9-1/2	5/8	57	68
	814-20EI-36	815-20EI-36	36	45	8	8-1/2	13-1/16	38-11/16	38-5/16	5/16	12-1/2	12-15/16	47	6	9-1/2	5/8	71	81
	814-20EI-42	815-20EI-42	42	51	8-1/2	9	15-1/16	44-7/16	44-1/16	5/16	13-11/16	14-1/16	53	7-1/2	9-1/2	5/8	93	102
	814-20EI-48	815-20EI-48	48	57	8-1/2	9	17-1/16	50-3/16	49-7/8	5/16	14-1/4	14-3/4	59	7-1/2	9-1/2	5/8	107	116
	814-20EI-54	815-20EI-54	54	63	8-1/2	9	19-1/16	55-15/16	55-5/8	3/8	15	15 1/2	65-1/2	9	11	5/8	116	125
	814-20EI-60	815-20EI-60	60	69	8-1/2	9	21-1/16	61-11/16	61-3/8	3/8	15-5/8	16-3/16	71-1/2	9	11	5/8	130	139
35°	814-35EI-18	815-35EI-18	18	27	8	8-1/2	7-1/16	19-5/8	19-1/16	1/4	12-1/8	12-1/4	29	6	8	1/2	42	48
	814-35EI-24	815-35EI-24	24	33	8	8-1/2	9-1/16	24-15/16	24-5/16	5/16	13-1/4	13-11/16	35	6	9-1/2	5/8	50	58
	814-35EI-30	815-35EI-30	30	39	8	8-1/2	11-1/16	30-3/16	29-5/8	5/16	14-7/16	14-11/16	41	6	9-1/2	5/8	62	69
	814-35EI-36	815-35EI-36	36	45	8	8-1/2	13-1/16	35-7/16	34-7/8	5/16	15-9/16	16	47	6	9-1/2	5/8	73	82
	814-35EI-42	815-35EI-42	42	51	8-1/2	9	15-1/16	40-3/4	40-3/16	5/16	17-3/16	17-9/16	53	7-1/2	9-1/2	5/8	95	104
	814-35EI-48	815-35EI-48	48	57	8-1/2	9	17-1/16	46	45-7/16	5/16	18-5/16	18-3/4	59	7-1/2	9-1/2	5/8	109	118
	814-35EI-54	815-35EI-54	54	63	8-1/2	9	19-1/16	51-5/16	50-3/4	3/8	19-1/2	19-7/8	65-1/2	9	11	5/8	118	127
	814-35EI-60	815-35EI-60	60	69	8-1/2	9	21-1/16	56-9/16	56	3/8	20-5/8	21-1/16	71-1/2	9	11	5/8	133	142
45°	814-45EI-18	815-45EI-18	18	27	8	8-1/2	7-1/16	18-1/4	17-9/16	1/4	12-1/8	12-7/16	29	6	8	1/2	44	50
	814-45EI-24	815-45EI-24	24	33	8	8-1/2	9-1/16	23-1/8	22-3/8	5/16	14-1/2	14-7/8	35	6	9-1/2	5/8	52	61
	814-45EI-30	815-45EI-30	30	39	8	8-1/2	11-1/16	27-15/16	27-1/4	5/16	15-15/16	16-5/16	41	6	9-1/2	5/8	62	72
	814-45EI-36	815-45EI-36	36	45	8	8-1/2	13-1/16	32-3/4	32-3/4	5/16	17-3/8	17-3/4	47	6	9-1/2	5/8	75	84
	814-45EI-42	815-45EI-42	42	51	8-1/2	9	15-1/16	37-9/16	36-7/8	5/16	19-1/4	19-9/16	53	7-1/2	9-1/2	5/8	97	106
	814-45EI-48	815-45EI-48	48	57	8-1/2	9	17-1/16	42-7/16	41-11/16	5/16	20-5/8	21	59	7-1/2	9-1/2	5/8	111	120
	814-45EI-54	815-45EI-54	54	63	8-1/2	9	19-1/16	47-1/4	46-9/16	3/8	22-1/16	22-7/16	65-1/2	9	11	5/8	121	130
	814-45EI-60	815-45EI-60	60	69	8-1/2	9	21-1/16	52-1/16	51-3/8	3/8	23-1/2	23-7/8	71-1/2	9	11	5/8	136	145

# 81 Series CEMA C Regreaseable Idlers

## Rubber Cushion Impact Troughing Idlers – 6” Diameter

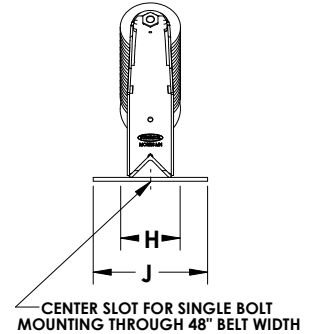
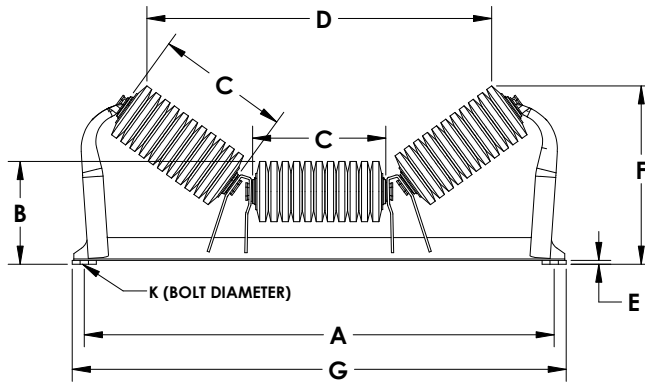

	6" PART NUMBER	BW*	A	B	C	D	E	F	G	H**	J	K	WT (#)
20°	816-20EI-18	18	27	9	7-1/16	20-11/16	1/4	11-5/16	29	6	8	1/2	49
	816-20EI-24	24	33	9	9-1/16	26-7/16	5/16	12	35	6	9-1/2	5/8	62
	816-20EI-30	30	39	9	11-1/16	32-1/4	5/16	12-3/4	41	6	9-1/2	5/8	74
	816-20EI-36	36	45	9	13-1/16	38	5/16	13-7/16	47	6	9-1/2	5/8	90
	816-20EI-42	42	51	9-1/2	15-1/16	43-3/4	5/16	14-9/16	53	7-1/2	9-1/2	5/8	111
	816-20EI-48	48	57	9-1/2	17-1/16	49-1/2	5/16	15-1/4	59	7-1/2	9-1/2	5/8	126
	816-20EI-54	54	63	9-1/2	19-1/16	55-1/4	3/8	15-15/16	65-1/2	9	11	5/8	136
	816-20EI-60	60	69	9-1/2	21-1/16	61	3/8	16-5/8	71-1/2	9	11	5/8	146
35°	816-35EI-18	18	27	9	7-1/16	18-1/2	1/4	12-15/16	29	6	8	1/2	51
	816-35EI-24	24	33	9	9-1/16	23-3/4	5/16	14-1/16	35	6	9-1/2	5/8	65
	816-35EI-30	30	39	9	11-1/16	29-1/16	5/16	15-1/4	41	6	9-1/2	5/8	77
	816-35EI-36	36	45	9	13-1/16	34-5/16	5/16	16-3/8	47	6	9-1/2	5/8	92
	816-35EI-42	42	51	9-1/2	15-1/16	39-5/8	5/16	18	53	7-1/2	9-1/2	5/8	113
	816-35EI-48	48	57	9-1/2	17-1/16	44-7/8	5/16	19-1/8	59	7-1/2	9-1/2	5/8	128
	816-35EI-54	54	63	9-1/2	19-1/16	50-1/8	3/8	20-5/16	65-1/2	9	11	5/8	139
	816-35EI-60	60	69	9-1/2	21-1/16	55-7/16	3/8	21-7/16	71-1/2	9	11	5/8	150
45°	<del>816-45EI-18</del>	<del>18</del>	<del>27</del>	<del>9</del>	<del>7-1/16</del>	<del>16-7/8</del>	<del>1/4</del>	<del>13-13/16</del>	<del>29</del>	<del>6</del>	<del>8</del>	<del>1/2</del>	<del>53</del>
	816-45EI-24	24	33	9	9-1/16	21-11/16	5/16	15-1/4	35	6	9-1/2	5/8	67
	816-45EI-30	30	39	9	11-1/16	26-1/2	5/16	16-11/16	41	6	9-1/2	5/8	78
	816-45EI-36	36	45	9	13-1/16	32-1/16	5/16	18-1/16	47	6	9-1/2	5/8	94
	816-45EI-42	42	51	9-1/2	15-1/16	36-3/16	5/16	19-15/16	53	7-1/2	9-1/2	5/8	115
	816-45EI-48	48	57	9-1/2	17-1/16	41	5/16	21-3/8	59	7-1/2	9-1/2	5/8	131
	816-45EI-54	54	63	9-1/2	19-1/16	45-13/16	3/8	22-13/16	65-1/2	9	11	5/8	142
	816-45EI-60	60	69	9-1/2	21-1/16	50-9/16	3/8	24-3/16	71-1/2	9	11	5/8	153

81 Series

\* Belt Width (Reinforcing on 36" BW - 60" BW Impact Frame).

\*\* Recommended Bolt Pattern - See page 75 for minimum and maximum dimensions.

# 81 Series CEMA C Regreaseable Idlers

## Rubber Cushion Return Idlers – 4", 5", & 6" Diameter

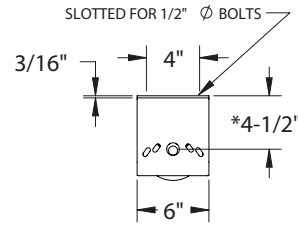
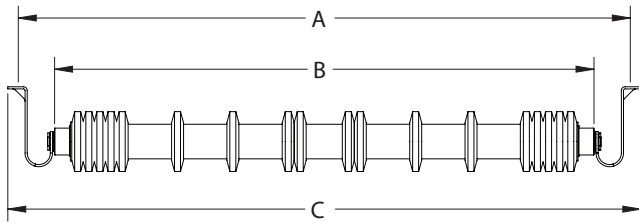

PART NUMBER			BW*	A	B	C	WT (#)**		
4"	5"	6"					4"	5"	6"
814-RETI-18	815-RETI-18	816-RETI-18	18	27	21-5/16	28-3/4	19	24	26
814-RETI-24	815-RETI-24	816-RETI-24	24	33	27-5/16	34-3/4	22	29	33
814-RETI-30	815-RETI-30	816-RETI-30	30	39	33-5/16	40-3/4	25	33	37
814-RETI-36	815-RETI-36	816-RETI-36	36	45	39-5/16	46-3/4	31	37	43
814-RETI-42	815-RETI-42	816-RETI-42	42	51	45-5/16	52-3/4	33	40	46
814-RETI-48	815-RETI-48	816-RETI-48	48	57	51-5/16	58-3/4	35	46	52
814-RETI-54 ✓	815-RETI-54 ✓	816-RETI-54 ✓	54	63	57-5/16	64-3/4	40	51	56
814-RETI-60 ✓	815-RETI-60 ✓	816-RETI-60 ✓	60	69	63-5/16	70-3/4	42	55	60

81 Series

## Rubber Cushion Flat Idlers – 4", 5", & 6" Diameter

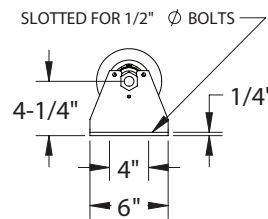
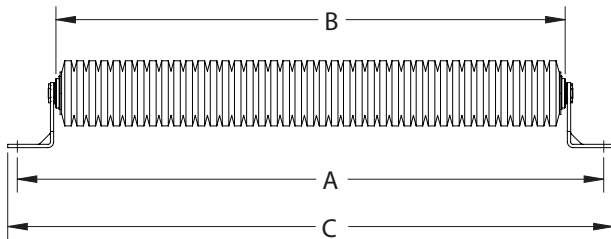

PART NUMBER			BW	A	B	C	WT (#)**		
4"	5"	6"					4"	5"	6"
814-FLTI-18	815-FLTI-18	816-FLTI-18	18	27	21-5/16	28-3/4	36	38	39
814-FLTI-24	815-FLTI-24	816-FLTI-24	24	33	27-5/16	34-3/4	41	43	46
814-FLTI-30	815-FLTI-30	816-FLTI-30	30	39	33-5/16	40-3/4	47	49	52
814-FLTI-36	815-FLTI-36	816-FLTI-36	36	45	39-5/16	46-3/4	52	55	61
814-FLTI-42	815-FLTI-42	816-FLTI-42	42	51	45-5/16	52-3/4	60	63	69
814-FLTI-48	815-FLTI-48	816-FLTI-48	48	57	51-5/16	58-3/4	66	70	76
814-FLTI-54 ✓	815-FLTI-54 ✓	816-FLTI-54 ✓	54	63	57-5/16	64-3/4	72	76	84
814-FLTI-60 ✓	815-FLTI-60 ✓	816-FLTI-60 ✓	60	69	63-5/16	70-3/4	78	82	93

\*\* All weights include brackets, individual bracket weights are listed on page 74 and 75.

✓ Meets CEMA D specifications.

Note: Return and Flat idlers are supplied with hold down kit for positive locking.

# 81 Series CEMA C Regreaseable Idlers

## Self-Aligning Troughing Idler – 4" & 5" Diameter

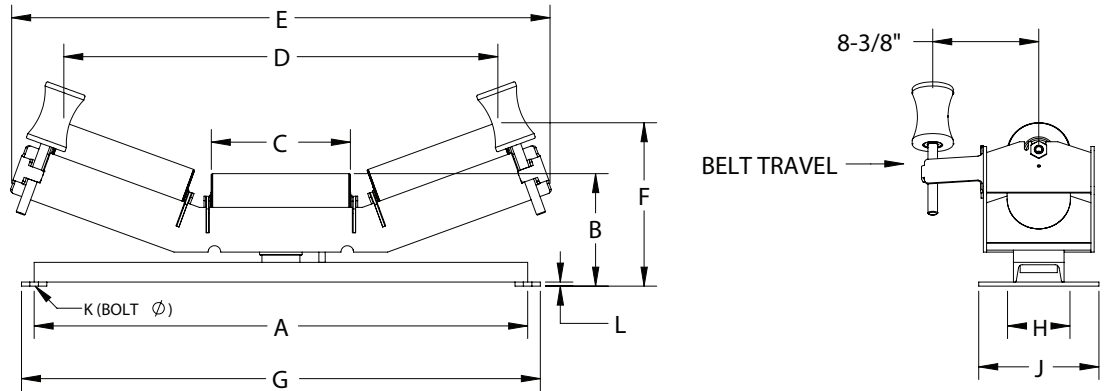

	PART NUMBER		BW	A	B		C	D		E	F		G	H*	J	K	L	WT (#)	
	4"	5"			4"	5"		4"	5"		4"	5"						4"	5"
20°	814-20EA-18	815-20EA-18	18	27	8-1/4	8-3/4	7-1/16	23-1/4	22-15/16	30-15/16	10-15/16	11-7/16	29	6	8	1/2	3/16	70	76
	814-20EA-24	815-20EA-24	24	33	8-1/4	8-7/8	9-1/16	29	28-11/16	36-5/89	11-3/4	12-1/4	35	6	9-1/2	1/2	5/16	79	88
	814-20EA-30	815-20EA-30	30	39	8-3/8	8-7/8	11-1/16	34-3/4	34-7/16	42-7/16	12-7/16	12-15/16	41	6	9-1/2	1/2	5/16	90	99
	814-20EA-36	815-20EA-36	36	45	8-7/8	8-7/8	13-1/16	40-1/2	40-3/16	48-3/16	13-1/8	13-5/8	47	6	9-1/2	1/2	5/16	99	109
	814-20EA-42	815-20EA-42	42	51	8-7/8	9-3/8	15-1/16	46-1/8	45-13/16	53-13/16	14-5/16	14-13/16	53	7-1/2	9-1/2	5/8	5/16	113	124
	814-20EA-48	815-20EA-48	48	57	8-7/8	9-3/8	17-1/16	51-7/8	51-9/16	59-9/16	15	15-1/2	59	7-1/2	9-1/2	5/8	5/16	122	135
	814-20EA-54	815-20EA-54	54	63	8-7/8	9-3/8	19-1/16	57-5/8	57-5/16	65-5/16	15-11/16	16-3/16	65	9	11	5/8	5/16	132	146
	814-20EA-60	815-20EA-60	60	69	8-15/16	9-7/16	21-1/16	63-3/8	63-1/16	71-1/16	16-7/16	16-15/16	71-1/2	9	11	5/8	3/8	145	160
35°	814-35EA-18	815-35EA-18	18	27	8-1/4	8-11/16	7-1/16	23-1/4	19-7/8	30-7/16	10-15/16	12-15/16	29	6	8	1/2	3/16	70	77
	814-35EA-24	815-35EA-24	24	33	8-3/8	8-13/16	9-1/16	29	25-1/8	35-11/16	11-3/4	14-3/16	35	6	9-1/2	1/2	5/16	81	89
	814-35EA-30	815-35EA-30	30	39	8-3/8	8-13/16	11-1/16	34-3/4	30-3/8	41	12-7/16	15-3/8	41	6	9-1/2	1/2	5/16	90	99
	814-35EA-36	815-35EA-36	36	45	8-3/8	8-13/16	13-1/16	40-1/2	35-11/16	46-1/4	13-1/8	16-1/2	47	6	9-1/2	1/2	5/16	99	110
	814-35EA-42	815-35EA-42	42	51	8-7/8	9-5/16	15-1/16	46-1/8	40-5/8	51-3/16	14-5/16	18-1/8	53	7-1/2	9-1/2	5/8	5/16	113	125
	814-35EA-48	815-35EA-48	48	57	8-7/8	9-5/16	17-1/16	51-7/8	45-15/16	56-1/2	15	19-5/16	59	7-1/2	9-1/2	5/8	5/16	122	136
	814-35EA-54	815-35EA-54	54	63	8-7/8	9-5/16	19-1/16	57-5/8	51-3/16	61-3/4	15-11/16	20-7/16	65	9	11	5/8	5/16	132	147
	814-35EA-60	815-35EA-60	60	69	8-15/16	9-3/8	21-1/16	63-3/8	56-7/16	67-1/16	16-7/16	21-11/16	71-1/2	9	11	5/8	3/8	145	161
45°	<del>814-45EA-18</del>	<del>815-45EA-18</del>	<del>18</del>	<del>27</del>	<del>8-2/16</del>	<del>8-11/16</del>	<del>7-1/16</del>	<del>23-1/4</del>	<del>19-7/8</del>	<del>30-7/16</del>	<del>10-15/16</del>	<del>12-15/16</del>	<del>29</del>	<del>6</del>	<del>8</del>	<del>1/2</del>	<del>3/16</del>	<del>70</del>	<del>77</del>
	814-45EA-24	815-45EA-24	24	33	8-5/16	8-13/16	9-1/16	24-3/8	23-11/16	35-5/8	14-15/16	15-5/16	35	6	9-1/2	1/2	5/16	82	90
	814-45EA-30	815-45EA-30	30	39	8-5/16	8-13/16	11-1/16	29-3/16	28-9/16	40-7/16	16-3/8	16-11/16	41	6	9-1/2	1/2	5/16	92	101
	814-45EA-36	815-45EA-36	36	45	8-5/16	8-13/16	13-1/16	34	33-3/8	45-1/4	17-3/4	18-1/8	47	6	9-1/2	1/2	5/16	101	111
	814-45EA-42	815-45EA-42	42	51	8-13/16	9-5/16	15-1/16	38-7/16	37-13/16	49-11/16	19-11/16	20	53	7-1/2	9-1/2	5/8	5/16	115	126
	814-45EA-48	815-45EA-48	48	57	8-13/16	9-5/16	17-1/16	43-1/4	42-5/8	54-1/2	21-1/16	21-7/16	59	7-1/2	9-1/2	5/8	5/16	125	137
	814-45EA-54	815-45EA-54	54	63	8-13/16	9-5/16	19-1/16	48-1/8	47-7/16	59-3/8	22-1/2	22-7/8	65	9	11	5/8	5/16	134	149
	814-45EA-60	815-45EA-60	60	69	8-7/8	9-3/8	21-1/16	52-15/16	52-1/4	64-3/16	24	24-5/16	71-1/2	9	11	5/8	3/8	147	162

81 Series

# 81 Series CEMA C Regreaseable Idlers

## Self-Aligning Troughing Idler – 6" Diameter

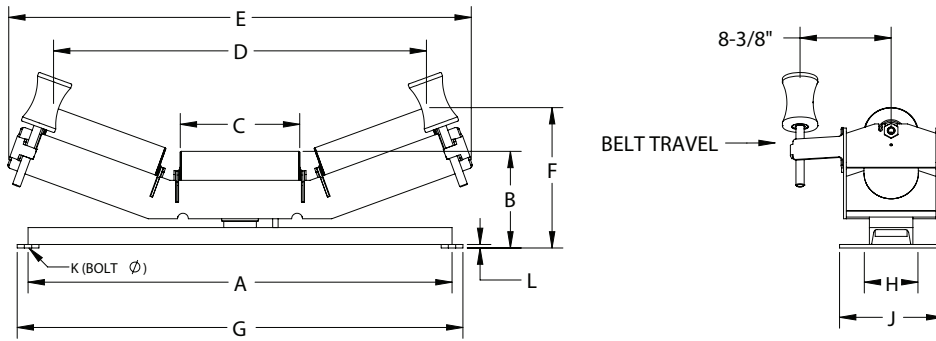

	6" PART NUMBER													WT (#)
	BW	A	B	C	D	E	F	G	H	J	K	L		
20°	816-20EA-18	18	27	9 1/4	7-1/16	22-9/16	30-15/16	11-7/8	29	6	8	1/2	3/16	83
	816-20EA-24	24	33	9-3/8	9-1/16	28-5/16	36-11/16	12-11/16	35	6	9-1/2	1/2	5/16	98
	816-20EA-30	30	39	9-3/8	11-1/16	34-1/8	42-7/16	13-3/8	41	6	9-1/2	1/2	5/16	111
	816-20EA-36	36	45	9-3/8	13-1/16	39-7/8	48-3/16	14 1/16	47	6	9-1/2	1/2	5/16	123
	816-20EA-42	42	51	9-7/8	15-1/16	45-7/16	53-13/16	15-1/4	53	7-1/2	9-1/2	5/8	5/16	140
	816-20EA-48	48	57	9-7/8	17-1/16	51-3/16	59-9/16	15-15/16	59	7-1/2	9-1/2	5/8	5/16	153
	816-20EA-54	54	63	9-7/8	19-1/16	56-15/16	65-5/16	16-5/8	65	9	11	5/8	5/16	166
	816-20EA-60	60	69	9-15/16	21-1/16	62-11/16	71-1/16	17-3/8	71-1/2	9	11	5/8	3/8	182
35°	816-35EA-18	18	27	9-3/16	7-1/16	19-1/4	30-7/16	13-5/16	29	6	8	1/2	3/16	84
	816-35EA-24	24	33	9-5/16	9-1/16	24-9/16	35-11/16	14-5/8	35	6	9-1/2	1/2	5/16	99
	816-35EA-30	30	39	9-5/16	11-1/16	29-13/16	41	15-3/4	41	6	9-1/2	1/2	5/16	111
	816-35EA-36	36	45	9-5/16	13-1/16	35-1/8	46-1/4	16-15/16	47	6	9-1/2	1/2	5/16	124
	816-35EA-42	42	51	9-13/16	15-1/16	40-1/16	51-3/16	18-9/16	53	7-1/2	9-1/2	5/8	5/16	141
	816-35EA-48	48	57	9-13/16	17-1/16	45-3/8	56-1/2	19-11/16	59	7-1/2	9-1/2	5/8	5/16	154
	816-35EA-54	54	63	9-13/16	19-1/16	50-5/8	61-3/4	20-7/8	65	9	11	5/8	5/16	167
	816-35EA-60	60	69	9-7/8	21-1/16	55-7/8	67-1/16	22-1/16	71-1/2	9	11	5/8	3/8	183
45°	<del>816-45EA-18</del>	<del>18</del>	<del>27</del>	<del>9-3/16</del>	<del>7-1/16</del>	<del>18-3/16</del>	<del>30-13/16</del>	<del>14-1/16</del>	<del>29</del>	<del>6</del>	<del>8</del>	<del>1/2</del>	<del>3/16</del>	<del>85</del>
	816-45EA-24	24	33	9-5/16	9-1/16	23	35-5/8	15-5/8	35	6	9-1/2	1/2	5/16	100
	816-45EA-30	30	39	9-5/16	11-1/16	27-7/8	40-7/16	17-1/16	41	6	9-1/2	1/2	5/16	113
	816-45EA-36	36	45	9-5/16	13-1/16	32-11/16	45-1/4	18-7/16	47	6	9-1/2	1/2	5/16	125
	816-45EA-42	42	51	9-13/16	15-1/16	37-1/16	49-11/16	20-3/8	53	7-1/2	9-1/2	5/8	5/16	142
	816-45EA-48	48	57	9-13/16	17-1/16	41-15/16	54-1/2	21-13/16	59	7-1/2	9-1/2	5/8	5/16	156
	816-45EA-54	54	63	9-13/16	19-1/16	46-3/4	59-3/8	23-3/16	65	9	11	5/8	5/16	168
	816-45EA-60	60	69	9-7/8	21-1/16	51-9/16	64-3/16	24-11/16	71-1/2	9	11	5/8	3/8	184

81 Series

## Self-Aligning Return Idlers – 4", 5", & 6" Diameter

PART NUMBER			BW	A	B	C	D	WT (#)**		
4"	5"	6"						4"	5"	6"
814-RETA-18	815-RETA-18	816-RETA-18	18	27	21-5/16	29-3/4	23-5/8	75	76	79
814-RETA-24	815-RETA-24	816-RETA-24	24	33	27-5/16	35-3/4	29-5/8	82	84	88
814-RETA-30	815-RETA-30	816-RETA-30	30	39	33-5/16	41-3/4	35-5/8	102	111	114
814-RETA-36	815-RETA-36	816-RETA-36	36	45	39-5/16	47-3/4	41-5/8	112	117	135
814-RETA-42	815-RETA-42	816-RETA-42	42	51	45-5/16	53-3/4	47-5/8	144	148	150
814-RETA-48	815-RETA-48	816-RETA-48	48	57	51-5/16	59-3/4	53-5/8	152	157	159
814-RETA-54	815-RETA-54	816-RETA-54	54	63	57-5/16	65-3/4	59-5/8	167	170	173
814-RETA-60	815-RETA-60	816-RETA-60	60	69	63-5/16	71-3/4	65-5/8	182	185	187

Note: Also available in bi-directional. Designated by (BA).

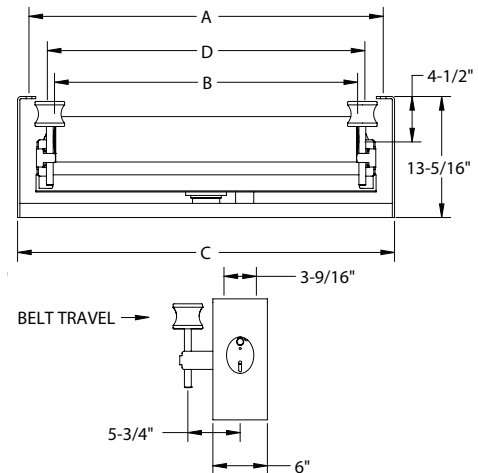

# 81 Series CEMA C Regreaseable Idlers

## Troughing Idlers (Unequal Length Rolls) – 4", 5", & 6" Diameter

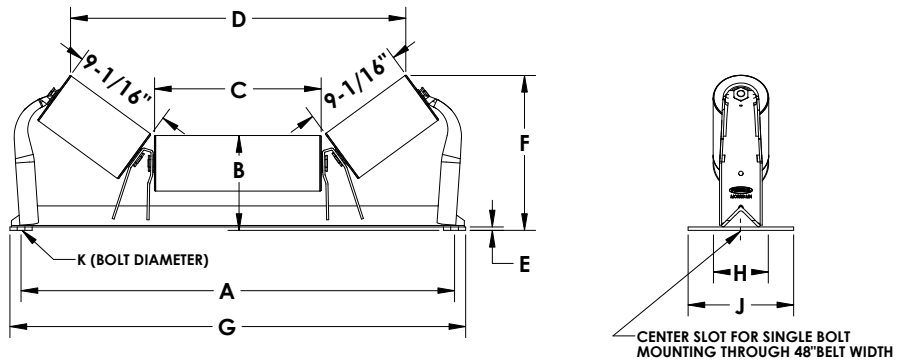

	4" PART NUMBER	BW*	A	B	C	D	E	F	G	H***	J	K	WT (#)
35°	814-35U-30	30	39	8	15-1/16	31-5/16	5/16	13-3/8	41	6	9-1/2	5/8	50
	814-35U-36	36	45	8	21-5/16	37-5/8	5/16	13-3/8	47	6	9-1/2	5/8	57
	814-35U-42	42	51	8-1/2	27-5/16	43-5/8	5/16	13-7/8	53	7-1/2	9-1/2	5/8	71
	814-35U-48	48	57	8-1/2	33-5/16	49-5/8	5/16	13-7/8	59	7-1/2	9-1/2	5/8	74
	814-35U-54	54	63	8-1/2	39-5/16	55-5/8	3/8	13-7/8	65-1/2	9	11	5/8	78
	814-35U-60	60	69	8	45-5/16	61-5/8	3/8	13-7/8	71-1/2	9	11	5/8	81
45°	814-45U-30	30	39	8	15-1/16	29-1/2	5/16	14-3/4	41	6	9-1/2	5/8	52
	814-45U-36	36	45	8-1/2	21-5/16	35-13/16	5/16	14-3/4	47	6	9-1/2	5/8	59
	814-45U-42	42	51	8-1/2	27-5/16	41-13/16	5/16	15-3/16	53	7-1/2	9-1/2	5/8	77
	814-45U-48	48	57	8-1/2	33-5/16	47-13/16	5/16	15-3/16	59	7-1/2	9-1/2	5/8	81
	814-45U-54	54	63	8-1/2	39-5/16	53-13/16	3/8	15-3/16	65-1/2	9	11	5/8	83
	814-45U-60	60	69	9	45-5/16	59-13/16	3/8	15-3/16	71-1/2	9	11	5/8	86

	PART NUMBER		BW*	A	B		C	D	E	F		G	H***	J	K	WT (#)	
	5"	6"			5"	6"				5"	6"					5"	6"
35°	815-35U-30	816-35U-30	30	39	8	9	15-1/16	31-5/16	5/16	13-3/8	14-1/4	41	6	9-1/2	5/8	50	61
	815-35U-36	816-35U-36	36	45	8	9	21-5/16	37-5/8	5/16	13-3/8	14-1/4	47	6	9-1/2	5/8	57	72
	815-35U-42	816-35U-42	42	51	8-1/2	9-1/2	27-5/16	43-5/8	5/16	13-7/8	14-11/16	53	7-1/2	9-1/2	5/8	71	86
	815-35U-48	816-35U-48	48	57	8-1/2	9-1/2	33-5/16	49-5/8	5/16	13-7/8	14-11/16	59	7-1/2	9-1/2	5/8	74	96
	815-35U-54	816-35U-54	54	63	8-1/2	9-1/2	39-5/16	55-5/8	3/8	13-7/8	14-11/16	65-1/2	9	11	5/8	78	102
	815-35U-60	816-35U-60	60	69	8	9-1/2	45-5/16	61-5/8	3/8	13-7/8	14-11/16	71-1/2	9	11	5/8	81	107
45°	815-45U-30	816-45U-30	30	39	8	9	15-1/16	29-1/2	5/16	14-3/4	15-7/16	41	6	9-1/2	5/8	52	63
	815-45U-36	816-45U-36	36	45	8-1/2	9	21-5/16	35-13/16	5/16	14-3/4	15-7/16	47	6	9-1/2	5/8	59	75
	815-45U-42	816-45U-42	42	51	8-1/2	9-1/2	27-5/16	41-13/16	5/16	15-3/16	15-7/8	53	7-1/2	9-1/2	5/8	77	92
	815-45U-48	816-45U-48	48	57	8-1/2	9-1/2	33-5/16	47-13/16	5/16	15-3/16	15-7/8	59	7-1/2	9-1/2	5/8	81	98
	815-45U-54	816-45U-54	54	63	8-1/2	9-1/2	39-5/16	53-13/16	3/8	15-3/16	15-15/16	65-1/2	9	11	5/8	83	104
	815-45U-60	816-45U-60	60	69	9	9-1/2	45-5/16	59-13/16	3/8	15-3/16	15-15/16	71-1/2	9	11	5/8	86	109

81 Series

\*\* Also available in rubber cushioned roller. Designated by (U). \*\*\* Recommended Bolt Pattern - See page 75 for minimum and maximum dimensions.

# 81 Series CEMA C Regreaseable Idlers

## Feeder / Picking Troughing Idlers – 4", 5", & 6" Diameter

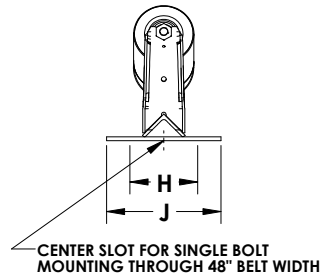
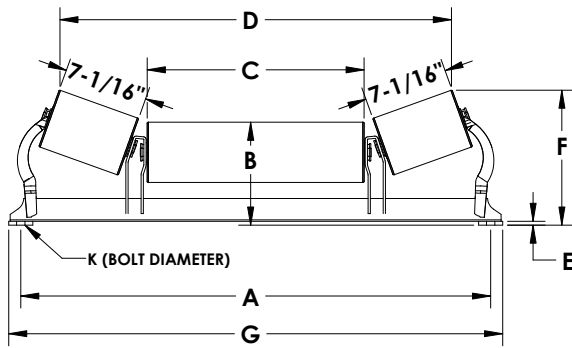

4" PART NUMBER	BW*	A	B	C	D	E	F	G	H**	J	K	WT (#)
814-20P-24	24	33	8	12-1/16	26-25/32	5/16	10-9/16	35	6	9-1/2	5/8	38
814-20P-30	30	39	8	18-1/16	32-7/8	5/16	10-9/16	41	6	9-1/2	5/8	45
814-20P-36	36	45	8	24-1/16	38-7/8	5/16	10-9/16	47	6	9-1/2	5/8	52
814-20P-42	42	51	8-1/2	30-1/16	44-7/8	5/16	11	53	7-1/2	9-1/2	5/8	70
814-20P-48	48	57	8-1/2	36-1/16	50-7/8	5/16	11	59	7-1/2	9-1/2	5/8	79
814-20P-54	54	63	8-1/2	42-1/16	56-7/8	3/8	11	65-1/2	9	11	5/8	87
814-20P-60	60	69	8-1/2	48-1/16	62-7/8	3/8	11	71-1/2	9	11	5/8	94

5" PART NUMBER	BW*	A	B	C	D	E	F	G	H**	J	K	WT (#)
815-20P-24	24	33	8-1/2	12-1/16	26-7/16	5/16	11	35	6	9-1/2	5/8	46
815-20P-30	30	39	8-1/2	18-1/16	32-9/16	5/16	11	41	6	9-1/2	5/8	53
815-20P-36	36	45	8-1/2	24-1/16	38-9/16	5/16	11	47	6	9-1/2	5/8	57
815-20P-42	42	51	9	30-1/16	44-9/16	5/16	11-1/2	53	7-1/2	9-1/2	5/8	75
815-20P-48	48	57	9	36-1/16	50-9/16	5/16	11-1/2	59	7-1/2	9-1/2	5/8	83
815-20P-54	54	63	9	42-1/16	56-9/16	3/8	11-1/2	65-1/2	9	11	5/8	95
815-20P-60	60	69	9	48-1/16	62-9/16	3/8	11-1/2	71-1/2	9	11	5/8	102

6" PART NUMBER	BW*	A	B	C	D	E	F	G	H**	J	K	WT (#)
816-20P-24	24	33	9	12-1/16	26-3/32	5/16	11-1/2	35	6	9-1/2	5/8	52
816-20P-30	30	39	9	18-1/16	32-3/16	5/16	11-1/2	41	6	9-1/2	5/8	59
816-20P-36	36	45	9	24-1/16	38-3/16	5/16	11-1/2	47	6	9-1/2	5/8	68
816-20P-42	42	51	9-1/2	30-1/16	44-3/16	5/16	11-15/16	53	7-1/2	9-1/2	5/8	85
816-20P-48	48	57	9-1/2	36-1/16	50-3/16	5/16	11-15/16	59	7-1/2	9-1/2	5/8	90
816-20P-54	54	63	9-1/2	42-1/16	56-3/16	3/8	11-15/16	65-1/2	9	11	5/8	106
816-20P-60	60	69	9-1/2	48-1/16	62-3/16	3/8	11-15/16	71-1/2	9	11	5/8	115

81 Series



# 81 Series CEMA C Regreaseable Idlers

## Offset Center Roll Idler – 5” & 6” Diameter

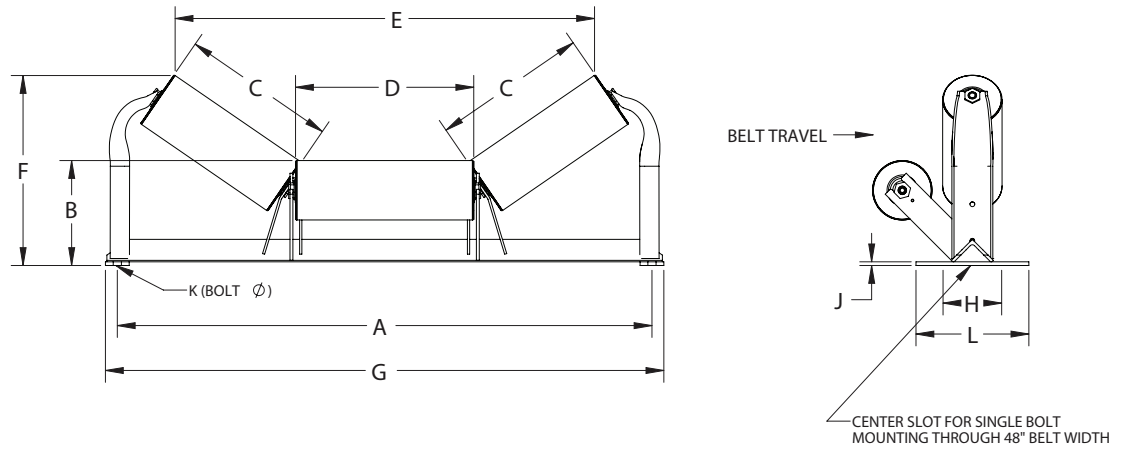

	PART NUMBER		BW	A	B		C	D	E		F		G	H	J	K*	L	WT (#)	
	5"	6"			5"	6"			5"	6"	5"	6"						5"	6"
20°	815-20GO-18	816-20GO-18	18	27	8-1/2	9	7-1/16	9-1/6	20-1/16	19-3/4	11	11-7/16	29	1/2	1/4	6	8	43	50
	815-20GO-24	816-20GO-24	24	33	8-1/2	9	9-1/16	11-1/16	25-13/16	25-1/2	11-11/16	12-1/8	35	5/8	5/16	6	9-1/2	50	58
	815-20GO-30	816-20GO-30	30	39	8-1/2	9	11-1/16	13-1/6	31-5/8	31-1/4	12-3/8	12-7/8	41	5/8	5/16	6	9-1/2	60	66
	815-20GO-36	816-20GO-36	36	45	8-1/2	9	13-1/16	15-1/6	37-3/8	37	13-1/16	13-9/16	47	5/8	5/16	6	9-1/2	64	75
	815-20GO-42	816-20GO-42	42	51	9	9-1/2	15-1/16	17-1/16	43-1/8	42-3/4	14-3/16	14-11/16	53	5/8	5/16	7-1/2	9-1/2	82	92
	815-20GO-48	816-20GO-48	48	57	9	9-1/2	17-1/16	19-1/16	48-7/8	48-9/16	14-7/8	15-3/8	59	5/8	5/16	7-1/2	9-1/2	91	98
	815-20GO-54	816-20GO-54	54	63	9	9-1/2	19-1/16	21-1/16	54-5/8	54-5/16	15-5/8	16-1/16	65-1/2	5/8	3/8	9	11	101	131
	815-20GO-60	816-20GO-60	60	69	9	9-1/2	21-1/16	23-5/16	60-3/8	60-1/16	16-5/16	16-3/4	71-1/2	5/8	3/8	9	11	125	139
35°	815-35GO-18	816-35GO-18	18	27	8-1/2	9	7-1/16	9-1/6	17-3/4	17-1/8	12-5/8	13-1/16	29	1/2	1/4	6	8	44	51
	815-35GO-24	816-35GO-24	24	33	8-1/2	9	9-1/16	11-1/16	23	22-7/16	13-13/16	14-3/16	35	5/8	5/16	6	9-1/2	56	60
	815-35GO-30	816-35GO-30	30	39	8-1/2	9	11-1/16	13-1/6	28-5/16	27-11/16	14-15/16	15-5/8	41	5/8	5/16	6	9-1/2	63	69
	815-35GO-36	816-35GO-36	36	45	8-1/2	9	13-1/16	15-1/6	33-9/16	33	16-1/8	16-1/2	47	5/8	5/16	6	9-1/2	69	81
	815-35GO-42	816-35GO-42	42	51	9	9-1/2	15-1/16	17-1/16	38-13/16	38-1/4	17-11/16	18-1/8	53	5/8	5/16	7-1/2	9-1/2	85	94
	815-35GO-48	816-35GO-48	48	57	9	9-1/2	17-1/16	19-1/16	44-1/8	43-9/16	18-7/8	19-1/4	59	5/8	5/16	7-1/2	9-1/2	97	105
	815-35GO-54	816-35GO-54	54	63	9	9-1/2	19-1/16	21-1/16	49-3/8	48-13/16	20	20-7/16	65-1/2	5/8	3/8	9	11	107	136
	815-35GO-60	816-35GO-60	60	69	9	9-1/2	21-1/16	23-5/16	54-11/16	54-1/8	21-3/16	21-9/16	71-1/2	5/8	3/8	9	11	131	145
45°	815-45GO-18	816-45GO-18	18	27	8-1/2	9	7-1/16	9-1/6	16-1/2	15-3/4	13-5/8	14	29	1/2	1/4	6	8	45	52
	815-45GO-24	816-45GO-24	24	33	8-1/2	9	9-1/16	11-1/16	21-5/16	20-5/8	15-1/16	15-7/16	35	5/8	5/16	6	9-1/2	58	61
	815-45GO-30	816-45GO-30	30	39	8-1/2	9	11-1/16	13-1/6	26-1/8	25-7/16	16-1/2	16-7/8	41	5/8	5/16	6	9-1/2	65	71
	815-45GO-36	816-45GO-36	36	45	8-1/2	9	13-1/16	15-1/6	30-15/16	30-1/4	17-15/16	18-1/4	47	5/8	5/16	6	9-1/2	73	81
	815-45GO-42	816-45GO-42	42	51	9	9-1/2	15-1/16	17-1/16	35-13/16	35-1/16	19-3/4	20-1/8	53	5/8	5/16	7-1/2	9-1/2	90	96
	815-45GO-48	816-45GO-48	48	57	9	9-1/2	17-1/16	19-1/16	40-5/8	39-15/16	21-3/16	21-9/16	59	5/8	5/16	7-1/2	9-1/2	100	107
	815-45GO-54	816-45GO-54	54	63	9	9-1/2	19-1/16	21-1/16	45-7/16	44-3/4	22-5/8	23	65-1/2	5/8	3/8	9	11	125	138
	815-45GO-60	816-45GO-60	60	69	9	9-1/2	21-1/16	23-5/16	50-1/4	49-9/16	24-1/16	24-3/8	71-1/2	5/8	3/8	9	11	133	147

\* Recommended Bolt Pattern - See page 75 for minimum and maximum dimensions.

# 81 Series CEMA C Regreaseable Idlers

## Low Profile Channel Mount – 4" & 5" Diameter

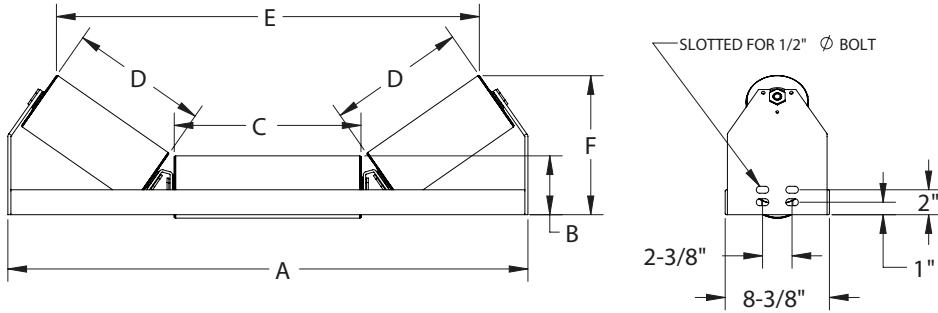

20°

81 Series

35°

PART NUMBER		BW	A	B		C	D	E		F		WT (#)	
4"	5"			4"	5"			4"	5"	4"	5"	4"	5"
814-20CM-18	815-20CM-18	18	23 5/8	4-1/2	5	7-1/16	6-1/16	19-7/8	19-1/2	6-11/16	7-3/16	36	39
814-20CM-24	815-20CM-24	24	29-5/8	4-1/2	5	11-1/16	7-1/16	25-25/32	25-7/16	7-1/16	7-9/16	43	49
814-20CM-30	815-20CM-30	30	35-5/8	4-1/2	5	13-1/16	9-1/16	31-1/2	31-3/16	7-3/4	8-1/4	52	57
814-20CM-36	815-20CM-36	36	41-5/8	4-1/2	5	15-1/16	11-1/16	37-11/32	37	8-7/16	8-15/16	60	64
814-20CM-42	815-20CM-42	42	47-5/8	4-1/2	5	17-1/16	13-1/16	43-3/32	42-3/4	9-3/32	9-5/8	73	79
814-20CM-48	815-20CM-48	48	53-5/8	4-1/2	5	19-1/16	15-1/16	48-13/16	48-15/32	9-13/16	10-5/16	85	90
814-20CM-54	815-20CM-54	54	59-5/8	4-1/2	5	21-5/16	17-1/16	54-13/16	54-1/2	10-1/2	11	100	106
814-20CM-60	815-20CM-60	60	65-5/8	4-1/2	5	23-5/16	19-1/16	60-1/2	60-3/8	11-3/16	11-11/16	115	120
814-35CM-18	815-35CM-18	18	23 5/8	4-1/2	5	7-1/16	6-1/16	18-9/32	17-11/16	8-3/16	8-9/16	36	39
814-35CM-24	815-35CM-24	24	29-5/8	4-1/2	5	11-1/16	7-1/16	25-15/16	23-3/8	8-3/4	9-5/32	43	49
814-35CM-30	815-35CM-30	30	35-5/8	4-1/2	5	13-1/16	9-1/16	29-1/4	28-21/32	9-29/32	10-5/16	52	57
814-35CM-36	815-35CM-36	36	41-5/8	4-1/2	5	15-1/16	11-1/16	34-1/2	33-15/16	11-1/32	11-7/16	60	64
814-35CM-42	815-35CM-42	42	47-5/8	4-1/2	5	17-1/16	13-1/16	39-3/4	39-1/4	12-3/16	12-5/8	73	79
814-35CM-48	815-35CM-48	48	53-5/8	4-1/2	5	19-1/16	15-1/16	45-1/16	44-1/2	13-11/32	13-3/4	85	90
814-35CM-54	815-35CM-54	54	59-5/8	4-1/2	5	21-5/16	17-1/16	50-9/16	50	14-1/2	14-7/8	102	108
814-35CM-60	815-35CM-60	60	65-5/8	4-1/2	5	23-5/16	19-1/16	55-7/8	55-1/4	15-5/8	16-1/16	117	122

Note: Also available with the rubber cushion rollers (Designated by CMI).

# 81 Series CEMA C Regreaseable Idlers

## Low Profile Standard Mount – 4” & 5” Diameter

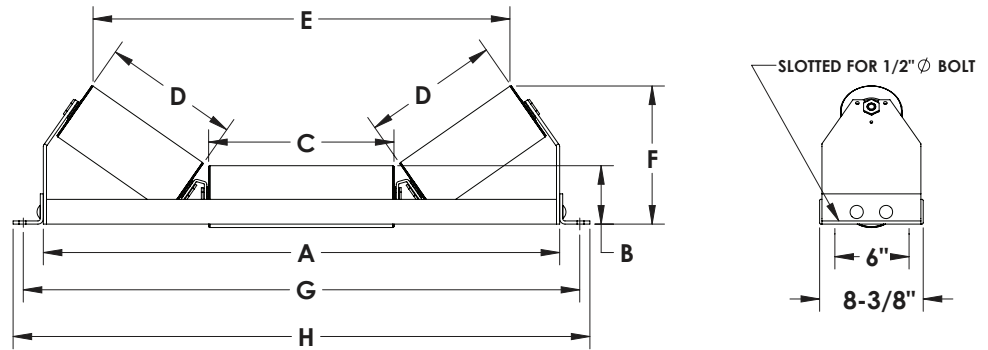

PART NUMBER		BW	A	B		C	D	G	H	E		F		WT (#)	
4"	5"			4"	5"					4"	5"	4"	5"	4"	5"
814-20SM-18	815-20SM-18	18	23-5/8	4-1/2	5	7-1/16	6-1/16	27	28-1/2	19-7/8	19-1/2	6-11/16	7-1/8	36	39
814-20SM-24	815-20SM-24	24	29-5/8	4-1/2	5	11-1/16	7-1/16	33	34-1/2	25-25/32	25-7/16	7	7-1/2	43	49
814-20SM-30	815-20SM-30	30	35-5/8	4-1/2	5	13-1/16	9-1/16	39	40-1/2	31-1/2	31-3/16	7-11/16	8-3/16	52	57
814-20SM-36	815-20SM-36	36	41-5/8	4-1/2	5	15-1/16	11-1/16	45	46-1/2	37-11/32	37	8-3/8	8-7/8	60	64
814-20SM-42	815-20SM-42	42	47-5/8	4-1/2	5	17-1/16	13-1/16	51	52-1/2	43-3/32	42-3/4	9-1/16	9-9/16	73	79
814-20SM-48	815-20SM-48	48	53-5/8	4-1/2	5	19-1/16	15-1/16	57	58-1/2	48-13/16	48-15/32	9-3/4	10-3/16	85	90
814-20SM-54	815-20SM-54	54	59-5/8	4-1/2	5	21-3/8	17-1/16	63	64-1/2	54-13/16	54-1/2	10-7/16	10-7/8	102	108
814-20SM-60	815-20SM-60	60	65-5/8	4-1/2	5	23-3/8	19-1/16	69	70-1/2	60-1/2	60-3/8	11-1/8	11-9/16	117	122
814-35SM-18	815-35SM-18	18	23-5/8	4-1/2	5	7-1/16	6-1/16	27	28-1/2	18-9/32	17-11/16	8-1/8	8-9/16	36	39
814-35SM-24	815-35SM-24	24	29-5/8	4-1/2	5	11-1/16	7-1/16	33	34-1/2	25-15/16	23-3/8	8-3/4	9-1/8	43	49
814-35SM-30	815-35SM-30	30	35-5/8	4-1/2	5	13-1/16	9-1/16	39	40-1/2	29-1/4	28-21/32	9-7/8	10-1/4	52	57
814-35SM-36	815-35SM-36	36	41-5/8	4-1/2	5	15-1/16	11-1/16	45	46-1/2	34-1/2	33-15/16	11	11-7/16	60	64
814-35SM-42	815-35SM-42	42	47-5/8	4-1/2	5	17-1/16	13-1/16	51	52 1/2	39-3/4	39-1/4	12-3/16	12-9/16	73	79
814-35SM-48	815-35SM-48	48	53-5/8	4-1/2	5	19-1/16	15-1/16	57	58-1/2	45-1/16	44-1/2	13-5/16	13-11/16	85	90
814-35SM-54	815-35SM-54	54	59-5/8	4-1/2	5	21-3/8	17-1/16	63	64-1/2	50-9/16	50	14-7/16	14-7/8	104	110
814-35SM-60	815-35SM-60	60	65-5/8	4-1/2	5	23-3/8	19-1/16	69	70-1/2	55-7/8	55-1/4	15-5/8	16	119	124

Note: Also available with the rubber cushion rollers (Designated by SMI).

# 91 Series CEMA D Regreaseable Idlers

## Troughing Idlers (Equal Length Rollers) – 5" & 6" Diameter

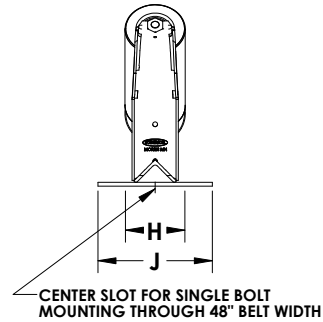
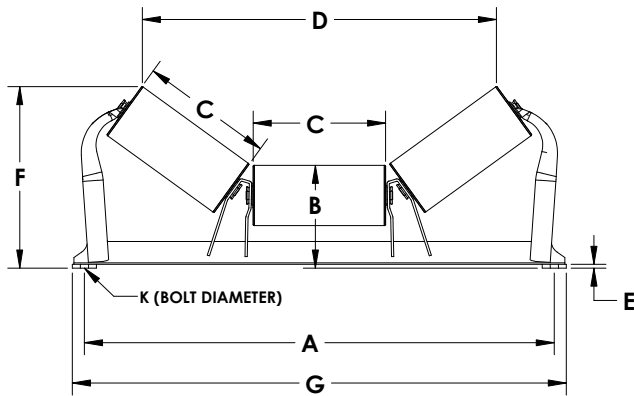

	PART NUMBER		BW	A	B		C	D		E	F		G	H*	J	K	WT (#)			
	5"	6"			5"	6"		5"	6"		5"	6"					5"	6"	5"	6"
20°	915-20E-24	916-20E-24	24	33	8-1/2	9	9-1/16	27-5/8	26-15/16	5/16	11-11/16	12-1/8	35	6	9-1/2	5/8	45	51		
	915-20E-30	916-20E-30	30	39	8-1/2	9	11-1/16	33-1/16	32-3/4	5/16	12-3/8	12-7/8	41	6	9-1/2	5/8	56	61		
	915-20E-36	916-20E-36	36	45	9	9-1/2	13-1/16	38-13/16	38-1/2	5/16	13-1/16	14-1/32	47	6	9-1/2	5/8	65	69		
	915-20E-42	916-20E-42	42	51	9	9-1/2	15-1/16	44-9/16	44-1/4	5/16	14-3/16	14-3/4	53	7-1/2	9-1/2	5/8	81	88		
	915-20E-48	916-20E-48	48	57	9-3/8	9-7/8	17-1/16	50-3/8	50	5/16	14-7/8	15-3/4	59	7-1/2	9-1/2	5/8	91	100		
	915-20E-54	916-20E-54	54	63	9-7/16	9-15/16	19-1/16	56-1/8	55-3/4	3/8	15-5/8	16-1/2	65-1/2	9	11	5/8	100	118		
	915-20E-60	916-20E-60	60	69	9-7/16	9-15/16	21-1/16	61-7/8	61-1/2	3/8	16-5/16	17-3/16	71-1/2	9	11	5/8	108	124		
	915-20E-72	916-20E-72	72	81	9-7/16	9-15/16	25-1/16	73-3/8	73	3/8	18-1/8	18-9/16	83-1/2	9	11	5/8	127	143		
35°	915-35E-24	916-35E-24	24	33	8-1/2	9	9-1/16	24-11/16	24-1/8	5/16	13-13/16	14-3/16	35	6	9-1/2	5/8	49	53		
	915-35E-30	916-35E-30	30	39	8-1/2	9	11-1/16	30	29-7/16	5/16	14-15/16	15-3/8	41	6	9-1/2	5/8	59	64		
	915-35E-36	916-35E-36	36	45	9	9-1/2	13-1/16	35-1/4	34-11/16	5/16	16-1/8	17	47	6	9-1/2	5/8	67	71		
	915-35E-42	916-35E-42	42	51	9	9-1/2	15-1/16	40-9/16	40	5/16	17-11/16	18-3/16	53	7-1/2	9-1/2	5/8	85	90		
	915-35E-48	916-35E-48	48	57	9-3/8	9-7/8	17-1/16	45-13/16	45-1/4	5/16	18-7/8	19-11/16	59	7-1/2	9-1/2	5/8	94	102		
	915-35E-54	916-35E-54	54	63	9-7/16	9-15/16	19-1/16	51-1/8	50-1/2	3/8	20	20-7/8	65-1/2	9	11	5/8	104	123		
	915-35E-60	916-35E-60	60	69	9-7/16	9-15/16	21-1/16	56-5/16	55-13/16	3/8	21-3/16	22	71-1/2	9	11	5/8	111	128		
	915-35E-72	916-35E-72	72	81	9-7/16	9-15/16	25-1/16	66-7/8	66-5/16	3/8	23-15/16	24-5/16	83-1/2	9	11	5/8	123	147		
45°	915-45E-24	916-45E-24	24	33	8-1/2	9	9-1/16	22-3/4	22-1/8	5/16	15-1/16	15-7/16	35	6	9-1/2	5/8	51	55		
	915-45E-30	916-45E-30	30	39	8-1/2	9	11-1/16	27-5/8	26-7/8	5/16	16-1/2	16-7/8	41	6	9-1/2	5/8	60	66		
	915-45E-36	916-45E-36	36	45	9	9-1/2	13-1/16	32-7/16	31-3/4	5/16	17-15/16	18-3/4	47	6	9-1/2	5/8	67	73		
	915-45E-42	916-45E-42	42	51	9	9-1/2	15-1/16	37-1/4	36-9/16	5/16	19-3/4	20-3/16	53	7-1/2	9-1/2	5/8	89	95		
	915-45E-48	916-45E-48	48	57	9-3/8	9-7/8	17-1/16	42-1/16	41-3/8	5/16	21-3/16	21-15/16	59	7-1/2	9-1/2	5/8	96	104		
	915-45E-54	916-45E-54	54	63	9-7/16	9-15/16	19-1/16	46-15/16	46-3/16	3/8	22-5/8	23-7/16	65-1/2	9	11	5/8	107	127		
	915-45E-60	916-45E-60	60	69	9-7/16	9-15/16	21-1/16	51-3/4	51	3/8	24-1/16	24-7/8	71-1/2	9	11	5/8	116	131		
	915-45E-72	916-45E-72	72	81	9-7/16	9-15/16	25-1/16	61-3/8	60-11/16	3/8	27-5/16	27-11/16	83-1/2	9	11	5/8	133	150		

\* Recommended Bolt Pattern - See page 75 for minimum and maximum dimensions.

# 91 Series CEMA D Regreaseable Idlers

## Return Idlers – 4" & 5" Diameter

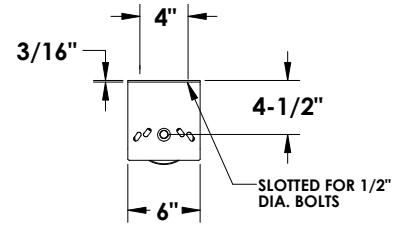
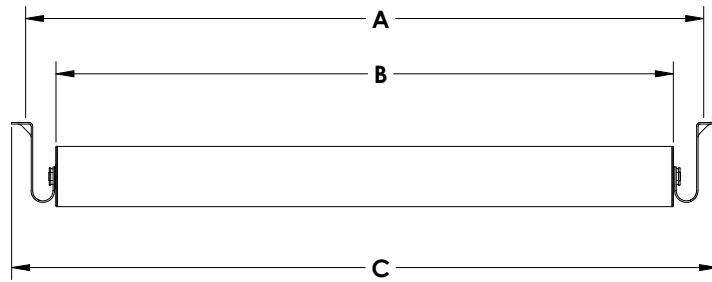

PART NUMBER		BW	A	B	C	WT (#)*	
5"	6"					5"	6"
915-RET-24	916-RET-24	24	33	27-5/16	34-3/4	31	36
915-RET-30	916-RET-30	30	39	33-5/16	40-3/4	36	40
915-RET-36	916-RET-36	36	45	39-5/16	46-3/4	40	47
915-RET-42	916-RET-42	42	51	45-5/16	52-3/4	42	50
915-RET-48	916-RET-48	48	57	51-5/16	58-3/4	50	57
915-RET-54	916-RET-54	54	63	57-5/16	64-3/4	55	61
915-RET-60	916-RET-60	60	69	63-5/16	70-3/4	60	65
915-RET-72	916-RET-72	72	81	75-5/16	82-3/4	64	70

## Flat Idlers – 4" & 5" Diameter

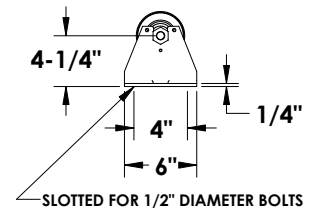
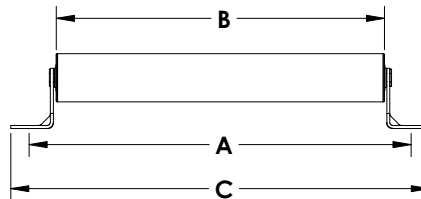

PART NUMBER		BW	A	B	C	WT (#)*	
5"	6"					5"	6"
915-FLT-24	916-FLT-24	24	33	27-5/16	34-3/4	32	36
915-FLT-30	916-FLT-30	30	39	33-5/16	40-3/4	36	40
915-FLT-36	916-FLT-36	36	45	39-5/16	46-3/4	40	47
915-FLT-42	916-FLT-42	42	51	45-5/16	52-3/4	43	50
915-FLT-48	916-FLT-48	48	57	51-5/16	58-3/4	50	57
915-FLT-54	916-FLT-54	54	63	57-5/16	64-3/4	55	61
915-FLT-60	916-FLT-60	60	69	63-5/16	70-3/4	60	65
915-FLT-72	916-FLT-72	72	81	75-5/16	82-3/4	64	70

\* All weights include brackets, individual bracket weights are listed on page 74 and 75. Note: Return and Flat idlers are supplied with hold down kit for positive locking.

# 91 Series CEMA D Regreaseable Idlers

## Rubber Cushion Impact Troughing Idler – 5" & 6" Diameter

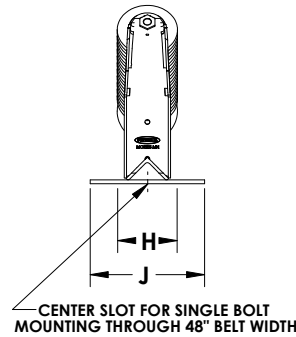
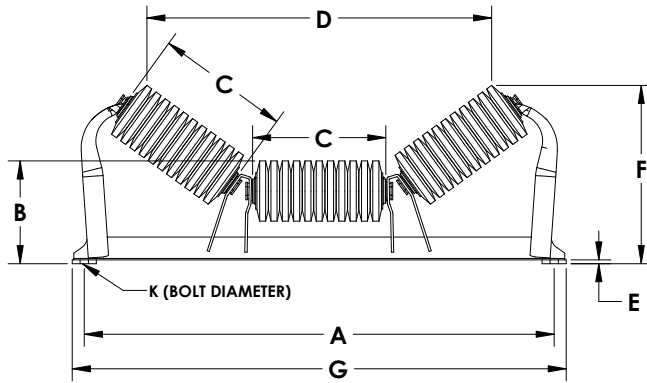

	PART NUMBER		BW*	A	B		C	D		E	F		G	H**	J	K	WT (#)	
	5"	6"			5"	6"		5"	6"		5"	6"					5"	6"
20°	915-20EI-24	916-20EI-24	24	33	8-1/2	9	9-1/16	26-13/16	26-7/16	5/16	11-11/16	12-1/8	35	6	9-1/2	5/8	53	65
	915-20EI-30	916-20EI-30	30	39	8-1/2	9	11-1/16	32-9/16	32-1/4	5/16	12-3/8	12-7/8	41	6	9-1/2	5/8	71	78
	915-20EI-36	916-20EI-36	36	45	9	9-1/2	13-1/16	38-5/16	38	5/16	13-9/16	14 1/32	47	6	9-1/2	5/8	83	94
	915-20EI-42	916-20EI-42	42	51	9	9-1/2	15-1/16	44-1/16	43-3/4	5/16	14-1/4	14-3/4	53	7-1/2	9-1/2	5/8	106	116
	915-20EI-48	916-20EI-48	48	57	9-3/8	9-7/8	17-1/16	49-7/8	49-1/2	5/16	15-5/16	15-3/4	59	7-1/2	9-1/2	5/8	120	131
	915-20EI-54	916-20EI-54	54	63	9-7/16	9-15/16	19-1/16	55-5/8	55-1/4	3/8	16-1/32	16-1/2	65-1/2	9	11	5/8	130	142
	915-20EI-60	916-20EI-60	60	69	9-7/16	9-15/16	21-1/16	61-3/8	61	3/8	16-3/4	17-3/16	71-1/2	9	11	5/8	145	152
	915-20EI-72	916-20EI-72	72	81	9-7/16	9-15/16	25-1/16	73	72-11/16	3/8	17-9/16	18-1/16	83-1/2	9	11	5/8	160	164
35°	915-35EI-24	916-35EI-24	24	33	8-1/2	9	9-1/16	24-5/16	23-3/4	5/16	11-11/16	14-3/16	35	6	9-1/2	5/8	60	68
	915-35EI-30	916-35EI-30	30	39	8-1/2	9	11-1/16	29-5/8	29-1/16	5/16	12-3/8	15-3/8	41	6	9-1/2	5/8	72	81
	915-35EI-36	916-35EI-36	36	45	9	9-1/2	13-1/16	34-7/8	34-5/16	5/16	16-5/8	16	47	6	9-1/2	5/8	85	96
	915-35EI-42	916-35EI-42	42	51	9	9-1/2	15-1/16	40-3/16	39-5/8	5/16	17-3/4	18-3/16	53	7-1/2	9-1/2	5/8	108	118
	915-35EI-48	916-35EI-48	48	57	9-3/8	9-7/8	17-1/16	45-7/16	44-7/8	5/16	19-1/4	19-11/16	59	7-1/2	9-1/2	5/8	123	133
	915-35EI-54	916-35EI-54	54	63	9-7/16	9-15/16	19-1/16	50-3/4	50-1/8	3/8	20-1/2	20-7/8	65-1/2	9	11	5/8	132	145
	915-35EI-60	916-35EI-60	60	69	9-7/16	9-15/16	21-1/16	56	55-7/16	3/8	21-5/8	22	71-1/2	9	11	5/8	148	157
	915-35EI-72	916-35EI-72	72	81	9-7/16	9-15/16	25-1/16	65-1/2	64-15/16	3/8	24-3/16	24-11/16	83-1/2	9	11	5/8	164	172
915-45EI-24	916-45EI-24	24	33	8-1/2	9	9-1/16	22-3/4	21-11/16	5/16	15-1/16	15-7/16	35	6	9-1/2	5/8	51	70	
45°	915-45EI-30	916-45EI-30	30	39	8-1/2	9	11-1/16	27-5/8	26-1/2	5/16	16-1/8	16-7/8	41	6	9-1/2	5/8	60	81
	915-45EI-36	916-45EI-36	36	45	9	9-1/2	13-1/16	32-7/16	32-1/16	5/16	18-7/16	18-3/4	47	6	9-1/2	5/8	67	98
	915-45EI-42	916-45EI-42	42	51	9	9-1/2	15-1/16	37-1/4	36-3/16	5/16	19-13/16	20-3/16	53	7-1/2	9-1/2	5/8	89	120
	915-45EI-48	916-45EI-48	48	57	9-3/8	9-7/8	17-1/16	42-1/16	41	5/16	21-5/8	21-15/16	59	7-1/2	9-1/2	5/8	96	136
	915-45EI-54	916-45EI-54	54	63	9-7/16	9-15/16	19-1/16	46-15/16	45-13/16	3/8	23-1/16	23-7/16	65-1/2	9	11	5/8	107	148
	915-45EI-60	916-45EI-60	60	69	9-7/16	9-15/16	21-1/16	51-3/4	50-9/16	3/8	24-1/2	24-7/8	71-1/2	9	11	5/8	116	159
	915-45EI-72	916-45EI-72	72	81	9-7/16	9-15/16	25-1/16	61-3/8	60-7/16	3/8	27-5/16	26-15/16	83-1/2	9	11	5/8	133	174

91 Series

# 91 Series CEMA D Regreaseable Idlers

## Rubber Cushion Return Idlers – 5” & 6” Diameter

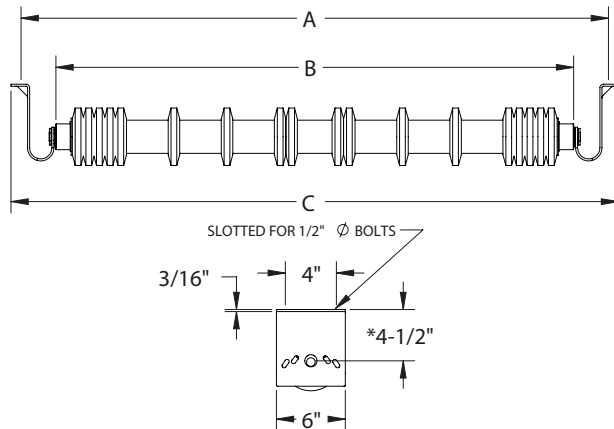

PART NUMBER		BW	A	B	C	WT (#)	
5"	6"					5"	6"
915-RETI-24	916-RETI-24	24	33	27-5/16	34-3/4	30	36
915-RETI-30	916-RETI-30	30	39	33-5/16	40-3/4	36	40
915-RETI-36	916-RETI-36	36	45	39-5/16	46-3/4	40	47
915-RETI-42	916-RETI-42	42	51	45-5/16	52-3/4	43	50
915-RETI-48	916-RETI-48	48	57	51-5/16	58-3/4	50	57
915-RETI-54	916-RETI-54	54	63	57-5/16	64-3/4	55	61
915-RETI-60	916-RETI-60	60	69	63-5/16	70-3/4	60	65
915-RETI-72	916-RETI-72	72	81	75-5/16	82-3/4	76	70

## Rubber Cushion Flat Idlers – 5” & 6” Diameter

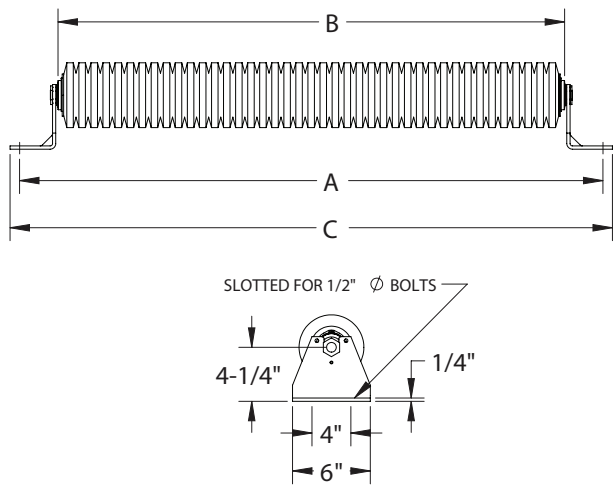

PART NUMBER		BW	A	B	C	WT (#)	
5"	6"					5"	6"
915-FLTI-24	916-FLTI-24	24	33	27-5/16	34-3/4	47	50
915-FLTI-30	916-FLTI-30	30	39	33-5/16	40-3/4	53	57
915-FLTI-36	916-FLTI-36	36	45	39-5/16	46-3/4	60	66
915-FLTI-42	916-FLTI-42	42	51	45-5/16	52-3/4	68	75
915-FLTI-48	916-FLTI-48	48	57	51-5/16	58-3/4	76	83
915-FLTI-54	916-FLTI-54	54	63	57-5/16	64-3/4	82	91
915-FLTI-60	916-FLTI-60	60	69	63-5/16	70-3/4	89	101
915-FLTI-72	916-FLTI-72	72	81	75-5/16	82-3/4	96	112

## Self-Aligning Return Idlers – 5” & 6” Diameter

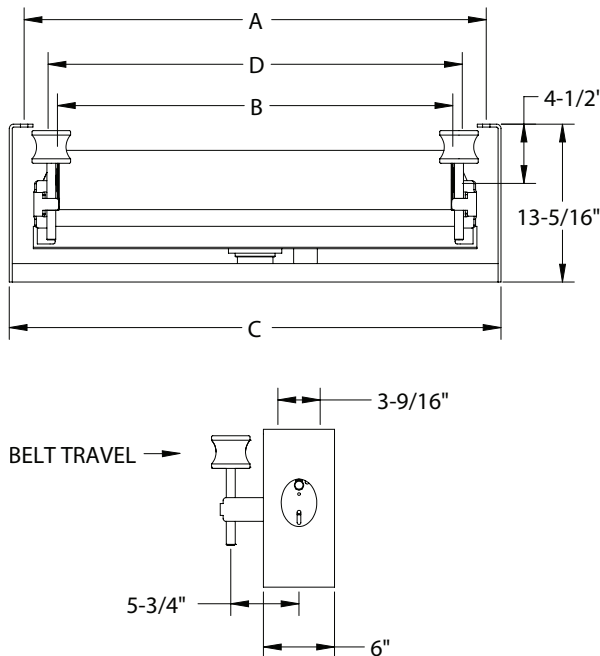

PART NUMBER		BW	A	B	C	D	WT (#)
5"	6"						
915-RETA-24	916-RETA-24	24	33	27-5/16	35-3/4	29-5/8	88
915-RETA-30	916-RETA-30	30	39	33-5/16	41-3/4	35-5/8	116
915-RETA-36	916-RETA-36	36	45	39-5/16	47-3/4	41-5/8	122
915-RETA-42	916-RETA-42	42	51	45-5/16	53-3/4	47-5/7	154
915-RETA-48	916-RETA-48	48	57	51-5/16	59-3/4	53-5/8	164
915-RETA-54	916-RETA-54	54	63	57-5/16	65-3/4	59-5/8	177
915-RETA-60	916-RETA-60	60	69	63-5/16	71-3/4	65-5/8	193
915-RETA-72	916-RETA-72	72	81	75-5/16	83-3/4	77-5/8	222

\*\* All weights include brackets  
 \*\* Also available in bi-directional. Designated by (RETBA). Individual bracket weights are listed on page 74 and 75.

# 91 Series CEMA D Regreaseable Idlers

## Self-Aligning Troughing Idlers – 5” & 6” Diameter

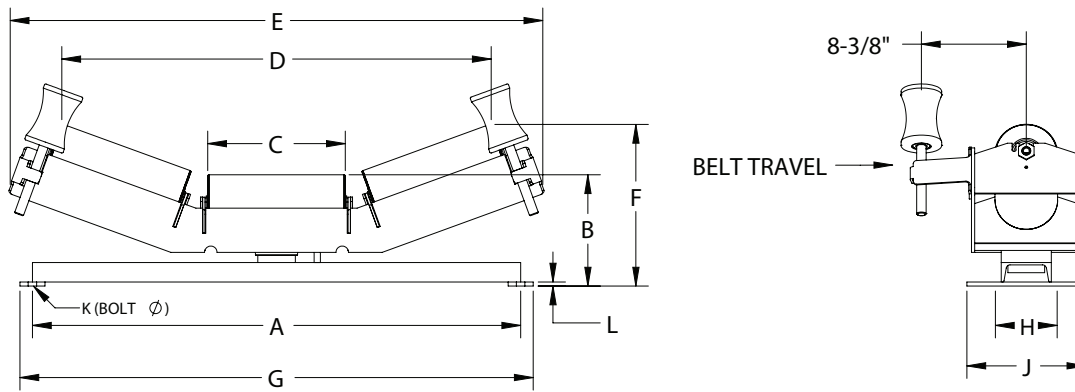

	PART NUMBER		BW	A	B		C	D		E	F		G	H	J	K	WT (#)	
	5"	6"			5"	6"		5"	6"		5"	6"					5"	6"
20°	915-20EA-24	916-20EA-24	24	33	9-9/16	10-1/16	9-1/16	27-5/16	26-15/16	36-3/4	12-3/4	13-3/16	35	6	11	1/2	96	100
	915-20EA-30	916-20EA-30	30	39	9-5/8	10-1/8	11-1/16	33-1/16	32-3/4	42-1/2	13-7/16	14	41	6	11	1/2	105	110
	915-20EA-36	916-20EA-36	36	45	9-5/8	10-1/8	13-1/16	38-13/16	38-1/2	48-1/8	14-1/8	14-5/8	47	6	11	1/2	116	120
	915-20EA-42	916-20EA-42	42	51	9-15/16	10-7/16	15-1/16	44-9/16	44-1/4	54-3/8	15-1/4	15-3/4	53	7-1/2	11	5/8	139	145
	915-20EA-48	916-20EA-48	48	57	9-15/16	10-7/16	17-1/16	50-3/8	50	60-5/8	16	16-7/16	59	7-1/2	11	5/8	149	156
	915-20EA-54	916-20EA-54	54	63	9-15/16	10-7/16	19-1/16	56-1/8	55-3/4	65	16-7/16	17-3/16	65-1/2	9	11	5/8	165	168
	915-20EA-60	916-20EA-60	60	69	9-15/16	10-7/16	21-1/16	61-7/8	61-1/2	70-1/2	17-1/4	17-13/16	71-1/2	9	11	5/8	175	182
	915-20EA-72	916-20EA-72	72	81	9-15/16	10-7/16	25-1/16	73-3/4	67-1/4	82-7/8	18-1/16	18-1/2	83-1/2	9	11	5/8	187	196
35°	915-35EA-24	916-35EA-24	24	33	9-9/16	10-1/16	9-1/16	24-11/16	24-1/8	37-1/2	14-7/8	15-1/4	35	6	11	1/2	98	100
	915-35EA-30	916-35EA-30	30	39	9-5/8	10-1/8	11-1/16	30	29-7/16	42-1/2	15-7/8	16-7/16	41	6	11	1/2	107	112
	915-35EA-36	916-35EA-36	36	45	9-5/8	10-1/8	13-1/16	35-1/4	34-11/16	47-5/8	17-3/16	17-9/16	47	6	11	1/2	118	122
	915-35EA-42	916-35EA-42	42	51	9-15/16	10-7/16	15-1/16	40-9/16	40	54-1/8	18-3/4	19-3/16	53	7-1/2	11	5/8	141	145
	915-35EA-48	916-35EA-48	48	57	9-15/16	10-7/16	17-1/16	45-13/16	45-1/4	59-3/4	20	20-5/16	59	7-1/2	11	5/8	151	157
	915-35EA-54	916-35EA-54	54	63	9-15/16	10-7/16	19-1/16	51-1/8	50-1/2	64	21-1/16	21-1/2	65-1/2	9	11	5/8	165	171
	915-35EA-60	916-35EA-60	60	69	9-15/16	10-7/16	21-1/16	56-5/16	55-13/16	69	22-1/4	22-5/8	71-1/2	9	11	5/8	177	183
	915-35EA-72	916-35EA-72	72	81	9-15/16	10-7/16	25-1/16	66-7/8	61-1/8	81-3/16	22-7/16	24-3/8	83-1/2	9	11	5/8	189	195
45°	915-45EA-24	916-45EA-24	24	33	9-9/16	10-1/16	9-1/16	22-3/4	22-1/8	26-1/8	16-1/8	16-1/2	25	6	11	1/2	90	101
	915-45EA-30	916-45EA-30	30	39	9-5/8	10-1/8	11-1/16	27-5/8	26-7/8	41-5/8	17-5/8	18	41	6	11	1/2	108	116
	915-45EA-36	916-45EA-36	36	45	9-5/8	10-1/8	13-1/16	32-7/16	31-3/4	46-3/8	19-1/16	19-3/8	47	6	11	1/2	119	123
	915-45EA-42	916-45EA-42	42	51	9-15/16	10-7/16	15-1/16	37-1/4	36-9/16	53-1/8	20-3/4	21-1/8	53	7-1/2	11	5/8	142	147
	915-45EA-48	916-45EA-48	48	57	9-15/16	10-7/16	17-1/16	42-1/16	41-3/8	58-1/4	22-3/16	21-7/8	59	7-1/2	11	5/8	153	159
	915-45EA-54	916-45EA-54	54	63	9-15/16	10-7/16	19-1/16	46-15/16	46-3/16	62-1/2	23-5/8	24	65-1/2	9	11	5/8	170	172
	915-45EA-60	916-45EA-60	60	69	9-15/16	10-7/16	21-1/16	51-3/4	51	66-3/4	25	25-3/8	71-1/2	9	11	5/8	179	184
	915-45EA-72	916-45EA-72	72	81	9-15/16	10-7/16	25-1/16	61-3/8	72-7/8	79-3/16	26-5/8	26-7/8	83-1/2	9	11	5/8	191	196

Note: Also available in rubber cushioned roller. Designated by (BA).



# 91 Series CEMA D Regreaseable Idlers

## Feeder / Picking Troughing Idlers – 5" & 6" Diameter

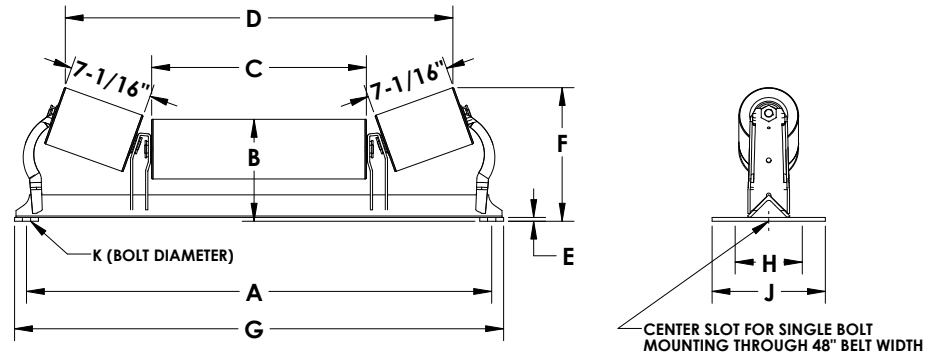

PART NUMBER		BW*	A	B		C	D		E	F		G	H**	J		K	WT (#)	
5"	6"			5"	6"		5"	6"		5"	6"			5"	6"		5"	6"
915-20P-24	916-20P-24	24	33	8-1/2	9	12-1/16	26-7/16	26-3/32	5/16	11	11-1/2	35	6	9-1/2	11	5/8	48	54
915-20P-30	916-20P-30	30	39	8-1/2	9	18-1/16	32-9/16	32-3/16	5/16	11	11-1/2	41	6	9-1/2	11	5/8	55	61
915-20P-36	916-20P-36	36	45	9	9-1/2	24-1/16	38-9/16	38-3/16	5/16	11	11-1/2	47	6	9-1/2	11	5/8	59	71
915-20P-42	916-20P-42	42	51	9	9-1/2	30-1/16	44-9/16	44-3/16	5/16	11-1/2	11-15/16	53	7-1/2	9-1/2	11	5/8	78	89
915-20P-48	916-20P-48	48	57	9-3/8	9-7/8	36-1/16	50-9/16	50-3/16	5/16	11-1/2	11-15/16	59	7-1/2	9-1/2	11	5/8	86	94
915-20P-54	916-20P-54	54	63	9-7/16	9-15/16	42-1/16	56-9/16	56-3/16	3/8	11-1/2	11-15/16	65-1/2	9	11	11	5/8	99	110
915-20P-60	916-20P-60	60	69	9-7/16	9-15/16	48-1/16	62-9/16	62-3/16	3/8	11-1/2	11-15/16	71-1/2	9	11	11	5/8	106	120
915-20P-72	916-20P-72	72	81	9-7/16	9-15/16	60-1/16	74-9/16	74-7/16	3/8	11-1/2	11-15/16	83-1/2	9	11	11	5/8	128	154

## Troughing Idlers (Unequal Length Rollers) 5" & 6" Diameter

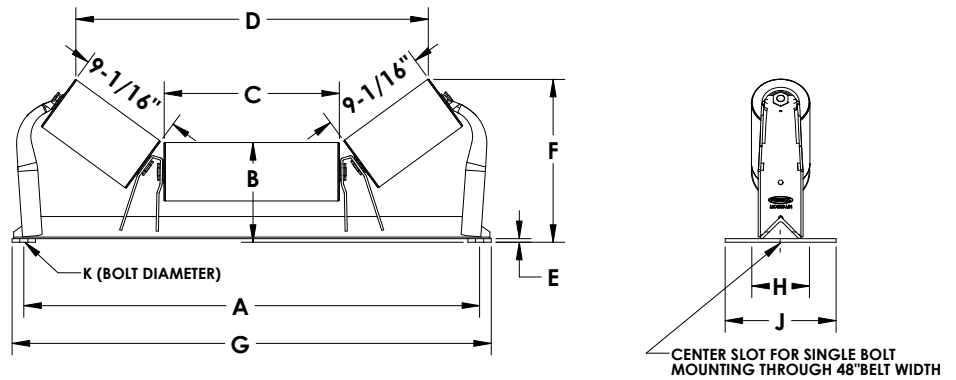

	PART NUMBER		BW*	A	B		C	D		E	F		G	H	J	K	WT (#)	
	5"	6"			5"	6"		5"	6"		5"	6"					5"	6"
35°	915-35U-30	916-35U-30	30	39	8-1/2	9	15-1/16	30-3/4	30-1/8	5/16	13-3/16	13-3/16	41	6	9-1/2	5/8	57	64
	915-35U-36	916-35U-36	36	45	9	9-1/2	21-5/16	37-1/16	36-1/2	5/16	13-3/16	13-3/16	47	6	9-1/2	5/8	65	75
	915-35U-42	916-35U-42	42	51	9	9-1/2	27-5/16	43-1/16	42-1/2	5/16	14-1/4	14-1/4	53	7-1/2	9-1/2	5/8	81	90
	915-35U-48	916-35U-48	48	57	9-3/8	9-7/8	33-5/16	49-1/16	48-1/2	5/16	14-1/4	14-1/4	59	7-1/2	9-1/2	5/8	92	100
	915-35U-54	916-35U-54	54	63	9-7/16	9-15/16	39-5/16	55-1/16	54-1/2	3/8	14-5/16	14-5/16	65-1/2	9	11	5/8	97	106
	915-35U-60	916-35U-60	60	69	9-7/16	9-15/16	45-5/16	61-1/16	60-1/2	3/8	14-5/16	14-5/16	71-1/2	9	11	5/8	106	111
45°	915-45U-30	916-45U-30	30	39	8-1/2	9	15-1/16	28-3/4	28-1/16	5/16	15-1/16	15-7/16	41	6	9-1/2	5/8	60	66
	915-45U-36	916-45U-36	36	45	9	9-1/2	21-5/16	35-1/8	34-3/8	5/16	15-1/16	15-7/16	47	6	9-1/2	5/8	68	78
	915-45U-42	916-45U-42	42	51	9	9-1/2	27-5/16	41-1/8	40-3/8	5/16	15-9/16	15-7/8	53	7-1/2	9-1/2	5/8	85	96
	915-45U-48	916-45U-48	48	57	9-3/8	9-7/8	33-5/16	47-1/8	46-3/8	5/16	15-9/16	15-7/8	59	7-1/2	9-1/2	5/8	95	102
	915-45U-54	916-45U-54	54	63	9-7/16	9-15/16	39-5/16	53-1/8	52-3/8	3/8	15-9/16	15-15/16	65-1/2	9	11	5/8	99	108
	915-45U-60	916-45U-60	60	69	9-7/16	9-15/16	45-5/16	59-1/8	58-3/8	3/8	15-9/16	15-15/16	71-1/2	9	11	5/8	109	113

91 Series

\* Belt Width (Reinforcing on 36" BW - 72" BW frame only).

\*\* Also available in rubber cushion rollers. Designated by (PI=picking impact) (UI=unequal impact).

# Regreaseable Idlers Parts

## Roller & Idler Components Parts 4", 5", & 6" Diameter

81 Series Replacement Rolls								
BW	Assembled Roll Approx. Length	4" Dia. Roll Part Number	WT (#)	5" Dia. Roll Part Number	WT (#)	6" Dia. Roll Part Number	WT (#)	
Equal Length Idler Rolls	18	7-1/16	814-18	6	815-18	8	816-18	9
	24	9-1/16	814-24	7	815-24	9	816-24	11
	30	11-1/16	814-30	8	815-30	11	816-30	12
	36	13-1/16	814-36	9	815-36	12	816-36	13
	42	15-1/16	814-42	10	815-42	13	816-42	15
	48	17-1/16	814-48	11	815-48	15	816-48	17
	54	19-1/16	814-54	12	815-54	16	816-54	19
	60	21-1/16	814-60	13	815-60	18	816-60	21
	Rubber Impact Idler Rolls	18	7-1/16	814-EI-18	8	815-EI-18	10	816-EI-18
24		9-1/16	814-EI-24	10	815-EI-24	12	816-EI-24	15
30		11-1/16	814-EI-30	12	815-EI-30	14	816-EI-30	17
36		13-1/16	814-EI-36	14	815-EI-36	16	816-EI-36	19
42		15-1/16	814-EI-42	17	815-EI-42	19	816-EI-42	22
48		17-1/16	814-EI-48	19	815-EI-48	21	816-EI-48	26
54		19-1/16	814-EI-54	21	815-EI-54	24	816-EI-54	27
60		21-1/16	814-EI-60	24	815-EI-60	26	816-EI-60	28

81 & 91 SERIES ROLL AND IDLER PARTS	
Part Number	Description
38-460083	Grease Tube
13-10041	Grease Zerk 1/8"
13-10043	Grease Zerk 1/4"
13-10044	Grease Relief Fitting 1/8"
08-10007	Hex Bushing 1/4"
13-10201	Center Clip 20°
13-10351	Center Clip 35°
13-10451	Center Clip 45°
13-10011	Screw-Rolock 1/4" x 3/8"
13-10039	Retainer Clip (Flat)
13-10040	Retainer Clip (Curved)
13-10052	Kit-Holder Down Clip (Ret & Fit)
09-104200	Rubber Disc 4" Dia. x 2" I.D.
09-105200	Rubber Disc 5" Dia. x 2" I.D.
09-104225	Rubber Disc 4" Dia. x 2 1/4" I.D.
09-105225	Rubber Disc 5" Dia. x 2 1/4" I.D.
09-106225	Rubber Disc 6" Dia. x 2 1/4" I.D.
03-01015	Kit-Bearing & Seal 81/91 Series

91 Series Replacement Rolls						
BW	Assembled Roll Approx. Length	5" Dia. Roll Part Number	WT (#)	6" Dia. Roll Part Number	WT (#)	
Equal Length Idler Rolls	18	7-1/16	915-18	8	916-18	9
	24	9-1/16	915-24	9	916-24	11
	30	11-1/16	915-30	11	916-30	12
	36	13-1/16	915-36	12	916-36	13
	42	15-1/16	915-42	13	916-42	15
	48	17-1/16	915-48	15	916-48	17
	54	19-1/16	915-54	16	916-54	19
	60	21-1/16	915-60	18	916-60	21
	72	25-1/16	915-72	23	916-72	27
Rubber Impact Idler Rolls	18	7-1/16	915-EI-18	10	916-EI-18	12
	24	9-1/16	915-EI-24	12	916-EI-24	15
	30	11-1/16	915-EI-30	14	916-EI-30	17
	36	13-1/16	915-EI-36	16	916-EI-36	19
	42	15-1/16	915-EI-42	19	916-EI-42	22
	48	17-1/16	915-EI-48	21	916-EI-48	26
	54	19-1/16	915-EI-54	24	916-EI-54	27
	60	21-1/16	915-EI-60	26	916-EI-60	28
	72	25-1/16	915-EI-72	31	916-EI-72	34

91 Series

# 40 Series Idlers

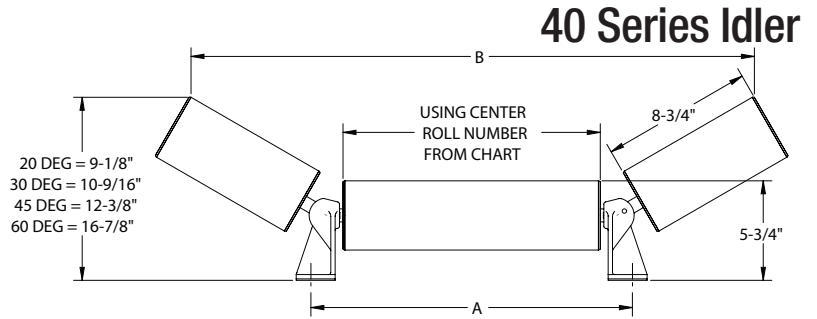

CENTER ROLL PART NUMBERS	POWERSCREEN #	RECOMMENDED BW	A	B				CENTER ROLL LENGTH	SHAFT LENGTH
				20°	30°	45°	60°T		
43-00010	07020238	24	11-7/8	27-15/16	25-13/16	21-3/4	13-9/16	8.14	9.20
43-00011	02021138	30	15-3/4	31-13/16	29-11/16	25-5/8	17-7/16	12.00	13.06
43-00012	08010101	30	18-5/8	34-11/16	32-9/16	28-1/2	20-5/16	14.87	15.93
43-00013	06530102	36	22-5/8	38-11/16	36-9/16	32-1/2	24-5/16	18.87	19.93
43-00014	05120115	36	24-9/16	40-5/8	38-1/2	34-7/16	26-1/4	20.87	21.87
43-00015	04220133	42	28-7/8	44-15/16	42-13/16	38-3/4	30-9/16	25.15	26.21
43-00016	09130180	42	30-1/2	46-9/16	44-7/16	40-3/8	32-3/16	26.75	27.81
43-00017	09120129	48	38-13/16	54-7/8	52-3/4	48-11/16	40-1/2	35.07	36.13
43-00018	03220103	54	39-9/16	55-5/8	53-1/2	49-7/16	41-1/4	33.87	36.87

## Center Brackets

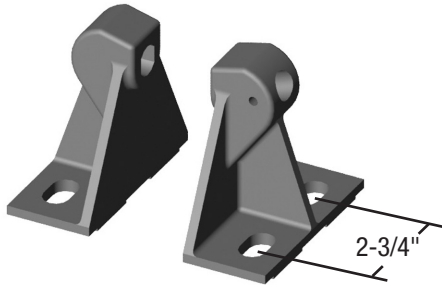

PART NUMBERS	POWERSCREEN #	DESCRIPTION	DEGREE
43-00021	LH2020608 RH2020609	Center bracket only	20
43-00022	LH2020606 RH2020607	Center bracket only	30
43-00023	LH2020604 RH2020605	Center bracket only	45
43-00024	LH2020610 RH2020611	Center bracket only	60

## Outside Rolls

PART NUMBER	POWERSCREEN #	DESCRIPTION	DEGREE	ROLL LENGTH
43-00019	8 - 3/4	Outside roller only	Fits all degrees	8-3/4"

## Return Rolls

PART NUMBERS	POWERSCREEN #	ROLL LENGTH	SHAFT LENGTH	METRIC SIZE	RECOMMENDED BELT WIDTH
43-00025	02021145	28.00"	33.00"	L840	24
43-00026	06530103	33.50"	38.50"	L978	30
43-00027	05420143	33.62"	38.62"	L980	30
43-00028	08010102	35.50"	40.50"	L1025	30
43-00029	05120116	40.00"	45.00"	L1145	36
43-00030	03220104	53.50"	58.50"	L1485	48
43-00031	07230107	62.00"	67.00"	L1700	60

## Return Roll U-Bolts

PART NUMBERS	SHAFT DIAMETER
13-03004	1"
13-03005	.75"

# CB 504 Series Idlers

## Troughing Idler – 4-1/2” Diameter

	4-1/2" PART NUMBER	BW	A	B	C	D	E	F	G	H	J	K	WT (#)
20°	CB45-20E-18	18	27	7 1/2	6-1/2	20-3/8	1/4	9-7/16	29	6	8	5/8	22
	CB45-20E-24	24	33	7-1/2	8-1/2	26-1/8	1/4	10-1/8	35	6	8	5/8	25
	CB45-20E-30	30	39	7-1/2	10-1/2	31-7/8	1/4	10-13/16	41	6	8	5/8	30
	CB45-20E-36	36	45	7-1/2	12-1/2	37-5/8	1/4	11-1/2	47	6	8	5/8	32
	CB45-20E-42	42	51	7-1/2	14-1/2	43-1/4	5/16	12-9/16	53	7-1/2	8	5/8	35
	CB45-20E-48	48	57	7-1/2	16-1/2	49	5/16	13-1/4	59	7-1/2	8	5/8	38
35°	CB45-35E-18	18	27	7-1/2	6 1/2	17-23/64	1/4	11-9/32	29	6	8	1/2	41
	CB45-35E-24	24	33	7-1/2	8-1/2	22-5/8	1/4	12-13/32	35	6	8	1/2	48
	CB45-35E-30	30	39	7-1/2	10-1/2	27-29/32	1/4	13-9/16	41	6	8	1/2	57
	CB45-35E-36	36	45	7-1/2	12 1/2	33-3/16	1/4	14-23/32	47	6	8	1/2	65
	CB45-35E-42	42	51	7-1/2	14-1/2	38-15/32	5/16	15-27/32	53	6	8	1/2	78
	CB45-35E-48	48	57	7-1/2	16-1/2	43-3/4	5/16	17	59	6	8	1/2	90

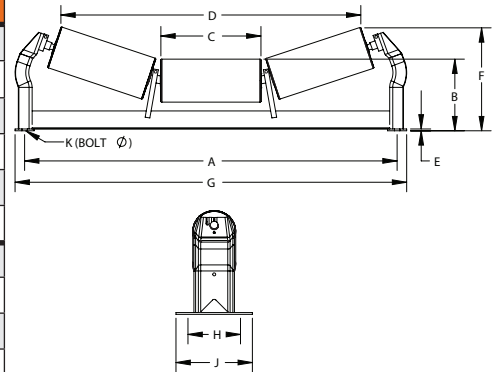

\*\* Also available in rubber cushioned roller. Designated by (EI).  
 Note: Also available in 4" diameter; dimensions are subject to change without notice.

## Low Profile Channel Mount – 4-1/2” Diameter

	4-1/2" PART NUMBER	BW	A	B	C	D	E	WT (#)
20°	CB45-20CM-18	18	23-3/4	4-7/8	6-1/2	20-1/8	7-1/4	36
	CB45-20CM-24	24	29-3/4	4-7/8	8-1/2	25-15/16	7-15/16	43
	CB45-20CM-30	30	35-3/4	4-7/8	10-1/2	31-21/32	8-5/8	52
	CB45-20CM-36	36	41-3/4	4-7/8	12-1/2	37-13/32	9-5/16	60
	CB45-20CM-42	42	47-3/4	4-7/8	14-1/2	43-3/16	10	73
	CB45-20CM-48	48	53-3/4	4-7/8	16-1/2	48-15/16	10-11/16	85
35°	CB45-35CM-18	18	23-3/4	4-7/8	6-1/2	17-3/8	7-25/32	37
	CB45-35CM-24	24	29-3/4	4-7/8	8-1/2	22-5/8	8-5/8	44
	CB45-35CM-30	30	35-3/4	4-7/8	10-1/2	27-15/16	10-15/16	53
	CB45-35CM-36	36	41-3/4	4-7/8	12-1/2	33-3/16	12-1/8	61
	CB45-35CM-42	42	47-3/4	4-7/8	14-1/2	38-15/32	13-1/4	74
	CB45-35CM-48	48	53-3/4	4-7/8	16-1/2	43-3/4	14-3/8	86

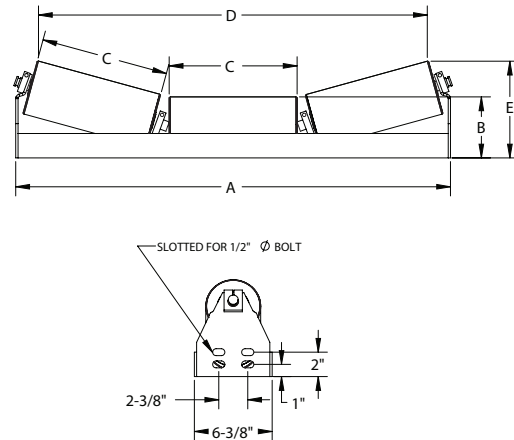

\*\* Also available in rubber cushioned roller. Designated by (CMI). Note: Dimensions are subject to change without notice. Certified prints available for construction.

## Bearing Stub Shaft Replacement Rollers 4" & 4-1/2" Diameter Ordering Guide

### CB45-10.50

1. Roll Diameter
2. Roll Length

CB 504 PARTS			
Part Number	Description	Part Number	Description
41-541250	2 1/2" Single Pin	30-456024	4-1/2" End Disc
41-542250	2 1/2" Double Pin	03-01017	CB 504 Bearing
41-542263	2 5/8" Double Pin	32-044081	1 1/2" Drop Bracket
41-541300	3" Single Pin	32-410450	4-1/2" Drop Bracket
41-542300	3" Double Pin	32-506000	Channel Mount Bracket
30-405044	4" End Disc		

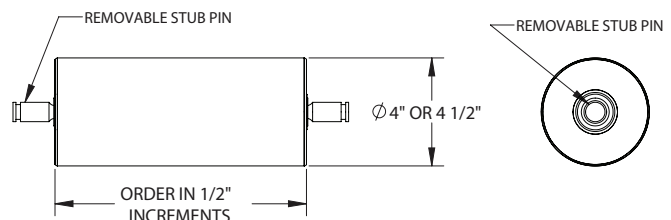

# Components Accessories

## Navigator Return Trainer– 7-3/4" & 7", 10" & 10-3/4" Diameter

Lagged 1.5" Drop

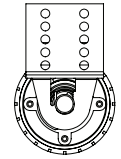
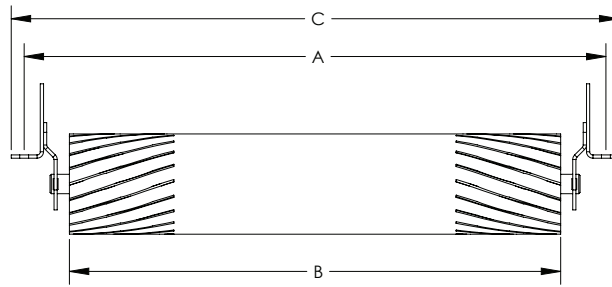

Lagged 4.5" Drop

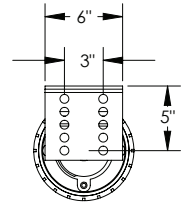
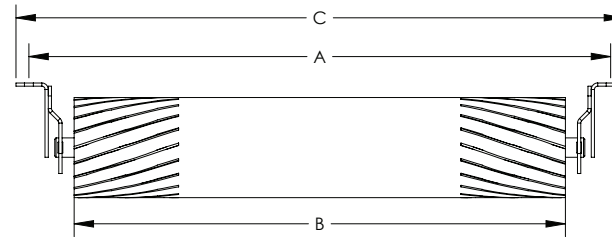

PART NUMBER		BW*	A	B	C	Diameter		WT (#)**		Standard Drop Bracket
LAGGED	NOT LAGGED					LAGGED	NOT LAGGED	LAGGED	NOT LAGGED	
NAV-24LAG	NAV-24	24	33	26	35	7-3/4	7	87	76	32-010009
NAV-30LAG	NAV-30	30	39	32	41	7-3/4	7	101	88	32-010009
NAV-36LAG	NAV-36	36	45	38	47	7-3/4	7	116	100	32-010009
NAV-42LAG	NAV-42	42	51	44	53	10-3/4	10	180	153	32-010019
NAV-48LAG	NAV-48	48	57	50	59	10-3/4	10	201	171	32-010019
NAV-54LAG	NAV-54	54	63	56	65	10-3/4	10	244	210	32-010020
NAV-60LAG	NAV-60	60	69	62	71	10-3/4	10	267	230	32-010020
NAV-66LAG	NAV-66	66	75	68	77	10-3/4	10	291	250	32-010020
NAV-72LAG	NAV-72	72	81	74	83	10-3/4	10	314	269	32-010020

## Return Guides Part Number: 42-000001

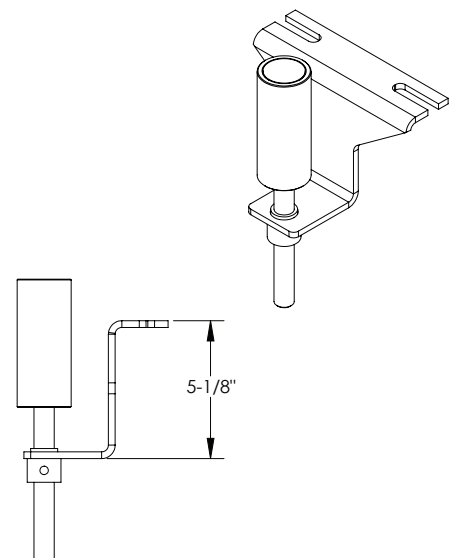
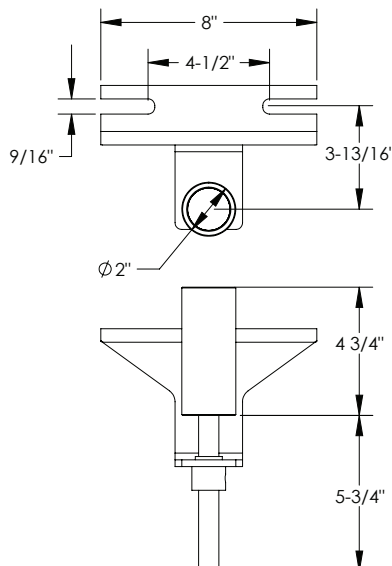

Accessories

# Component Accessories

## 80/81 & 90/91 Hex Style Roll Guard

PART NUMBER	BW	GUARD LENGTH
44-010018	18	21-1/8
44-010024	24	27-1/8
44-010030	30	33-1/8
44-010036	36	39-1/8
44-010042	42	45-1/8
44-010048	48	51-1/8
44-010054	54	57-1/8
44-010060	60	63-1/8
44-010072	72	75-1/8

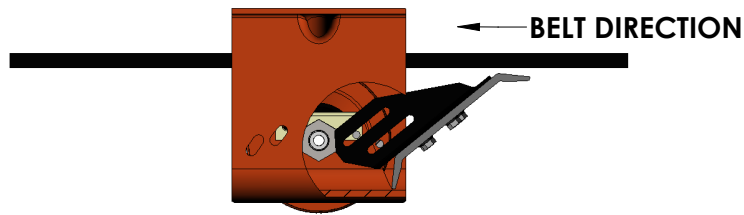

## Slotted Shaft Return Guard – Cema B, C, & D Idlers

\*fits on drop, rise, and channel mount brackets

PART NUMBER	BW	GUARD LENGTH
44-050118	18	21-1/8
44-050124	24	27-1/8
44-050130	30	33-1/8
44-050136	36	39-1/8
44-050142	42	45-1/8
44-050148	48	51-1/8
44-050154	54	57-1/8
44-050160	60	63-1/8
44-050172	72	75-1/8

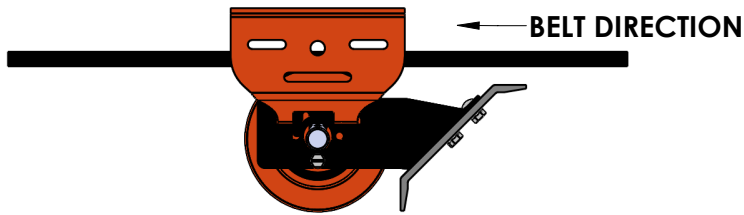

## Beater Bar Return Roll – 1 7/16" & 1 15/16" Shaft Size

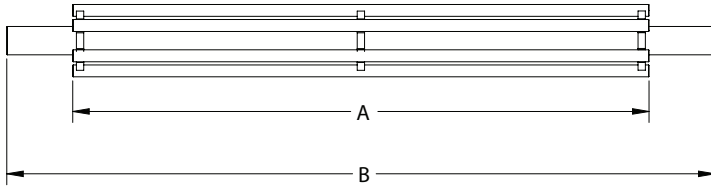

Roll Diameter		BW	A	B	WT		Roll Diameter		BW	A	B	WT (#)	
5"	6"				5"	6"	5"	6"				5"	6"
LSB-518-107	LSB-618-107	18	21-5/16	30-5/16	36	38	LSB-518-115	LSB-618-115	18	21-5/16	30-5/16	47	49
LSB-524-107	LSB-624-107	24	27-5/16	36-5/16	44	46	LSB-524-115	LSB-624-115	24	27-5/16	36-5/16	57	59
LSB-530-107	LSB-630-107	30	33-5/16	42-5/16	53	56	LSB-530-115	LSB-630-115	30	33-5/16	42-5/16	69	71
LSB-536-107	LSB-636-107	36	39-1/16	48-5/16	61	64	LSB-536-115	LSB-636-115	36	39-1/16	48-5/16	79	82
LSB-542-107	LSB-642-107	42	45-5/16	54-5/16	69	72	LSB-542-115	LSB-642-115	42	45-5/16	54-5/16	89	92
LSB-548-107	LSB-648-107	48	51-5/16	60-5/16	79	83	LSB-548-115	LSB-648-115	48	51-5/16	60-5/16	100	104
LSB-554-107	LSB-654-107	54	57-5/16	66-5/16	87	91	LSB-554-115	LSB-654-115	54	57-5/16	66-5/16	111	115
LSB-560-107	LSB-660-107	60	63-5/16	72-5/16	95	99	LSB-560-115	LSB-660-115	60	63-5/16	72-5/16	121	125
LSB-572-107	LSB-672-107	72	75-5/16	84-5/16	112	117	LSB-572-115	LSB-672-115	72	75-5/16	84-5/16	143	148

Part number for live shaft bearing 107: 03-02005

Part number for live shaft bearing 115: 03-02016

# Component Accessories

## Live Shaft Rollers – 4", 5" & 6" Diameter – Steel and Impact

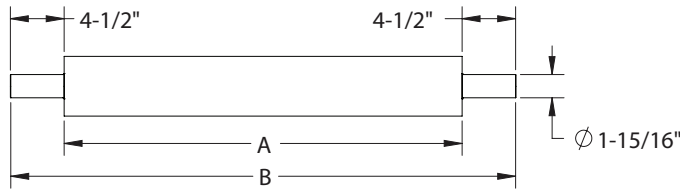

PART NUMBER						BW	A	B
4" DIA	WT (#)	5" DIA	WT (#)	6" DIA	WT (#)			
LS-418	41	LS-518	47	LS-618	54	18	21-5/16	30-5/16
LS-420	44	LS-520	51	LS-620	58	20	23-5/16	32-5/16
LS-424	51	LS-524	58	LS-624	66	24	27-5/16	36-5/16
LS-430	60	LS-530	68	LS-630	79	30	33-5/16	42-5/16
LS-436	69	LS-536	79	LS-636	91	36	39-5/16	48-5/16
LS-442	78	LS-542	89	LS-642	103	42	45-5/16	54-5/16
LS-448	87	LS-548	100	LS-648	115	48	51-5/16	60-5/16
LS-454	97	LS-554	111	LS-654	128	54	57-5/16	66-5/16
LS-460	106	LS-560	121	LS-660	140	60	63-5/16	72-5/16

Note: Impact designated by (LSI-)  
Bearings not included but available (03-02016 MP 1-15/16 Bearing)

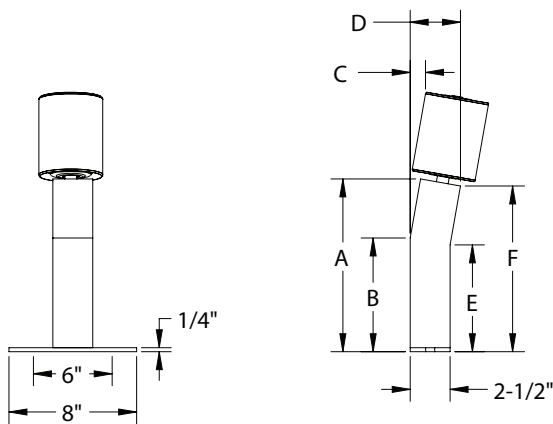

## Side Guide Idlers – 4" X 5-3/8" Rollers

Part Number	BW*	A	B	C	D	E	F
42-200020	14-20	9-3/16	7-3/16	11/16	3	6-13/16	8-5/16
42-200036	24-36	11-3/16	8-15/16	3/4	3-1/8	8-9/16	10-5/16
42-200048	42-48	13-7/16	11-3/16	3/4	3-1/8	10-13/16	12-9/16
42-200060	54-60	15-3/16	12-3/4	7/8	3-3/16	12-3/8	14-5/16
42-350030	14-24	12-11/16	10-5/8	1-5/16	3-5/16	10	11-1/4
42-350036	30-36	15-1/4	12-3/8	1-7/8	3-15/16	11-3/4	13-13/16
42-350048	42-48	17-15/16	14-1/8	2-9/16	4-9/16	13-1/2	16-1/2
42-350060	54-60	20-11/16	16	3-1/8	5-3/16	15-3/8	19-1/4

## Vertical Side Guide Roll – 2" & 4" Diameter

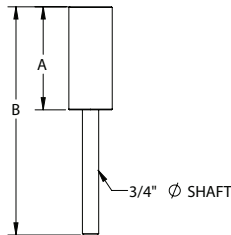

Part Number	A	B	WT (#)
42-020275	2-3/4	9-1/4	2
*46-200004	2-3/4	6-3/4	2
42-020475	4-3/4	10-1/2	3
*46-001247	4-3/4	7-3/4	3
42-604538	5-3/8	7-1/8	5

\* Threaded shaft

## Urethane Vertical Side Guide Roll 3-1/4" Diameter

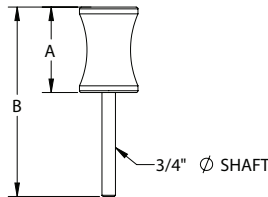

PART NUMBER	A	B	WT (#)
42-325275	2-3/4	9-1/4	5
*42-327275	2-3/4	6-3/4	5
42-325475	4-3/4	10-1/2	8
*42-327475	4-3/4	7-3/4	8

## Stub Roll Idlers – 4", 5" & 6" Diameter

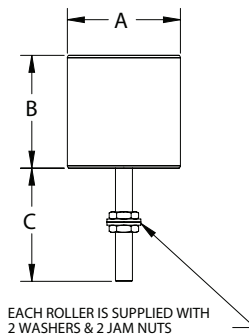

EACH ROLLER IS SUPPLIED WITH 2 WASHERS & 2 JAM NUTS

Part Number	A	B	C	SHAFT	THREAD
42-404458	4	4	4	17 MM	5/8-18
42-504458	5	4	4	17 MM	5/8-18
42-404558	4	4-1/2	4-1/2	17 MM	5/8-18
42-504558	5	4-1/2	4-1/2	17 MM	5/8-18
42-404475	4	4	4	3/4	3/4-16
42-505575	5	5	5	3/4	3/4-16
42-605575	6	5	5	3/4	3/4-16
42-405675	4	5	6	3/4	3/4-16
42-505675	5	5	6	3/4	3/4-16
42-606675	6	6	6	3/4	3/4-16

# Other Components Available

## Variable Pitch Idlers

- The variable pitch idler's outside rollers adjust from 5 to 35 degrees to meet numerous troughing requirements
- Available in CEMA C, D, and E
- SpinGuard® seal technology for long Lasting bearing protection
- Protects the belt from making sharp transitions
- Helps prevent spillage of material as each idler can be adjusted to keep a tight sealing system
- Available in both inline and offset versions  
 Inline: Easier to mount on the conveyors initially  
 Offset: Minimal roll gap to help prevent belt damage

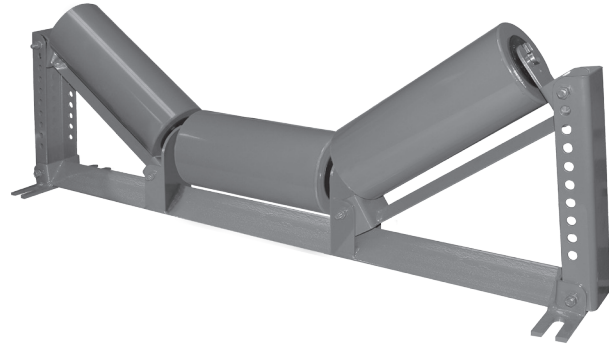

CEMA C Part Number			CEMA D Part Number		CEMA E Part Number		BW
4"	5"	6"	5"	6"	6"	7"	
C4-VPE-24	C5-VPE-24	C6-VPE-24	D5-VPE-24	D6-VPE-24	--	--	24
C4-VPE-30	C5-VPE-30	C6-VPE-30	D5-VPE-30	D6-VPE-30	--	--	30
C4-VPE-36	C5-VPE-36	C6-VPE-36	D5-VPE-36	D6-VPE-36	E6-VPE-36	E7-VPE-36	36
C4-VPE-42	C5-VPE-42	C6-VPE-42	D5-VPE-42	D6-VPE-42	E6-VPE-42	E7-VPE-42	42
C4-VPE-48	C5-VPE-48	C6-VPE-48	D5-VPE-48	D6-VPE-48	E6-VPE-48	E7-VPE-48	48
C4-VPE-54	C5-VPE-54	C6-VPE-54	D5-VPE-54	D6-VPE-54	E6-VPE-54	E7-VPE-54	54
C4-VPE-60	C5-VPE-60	C6-VPE-60	D5-VPE-60	D6-VPE-60	E6-VPE-60	E7-VPE-60	60
--	--	--	D5-VPE-72	D6-VPE-72	E6-VPE-72	E7-VPE-72	72
--	--	--	--	--	E6-VPE-84	E7-VPE-84	84
--	--	--	--	--	E6-VPE-96	E7-VPE-96	96

## Wire Rope Idlers

- Applicable for wire rope and rail type conveyors
- Offset center roller to stabilize idler and to provide zero roll gap so the belt doesn't pinch in the trough
- Includes SpinGuard® seal technology
- Easy clamping method for attaching to wire rope or bolting to rail frame
- Tubular cross member prevents excess build up of material
- Return brackets available
- Available in 35 degree as standard with 27 degree available upon request

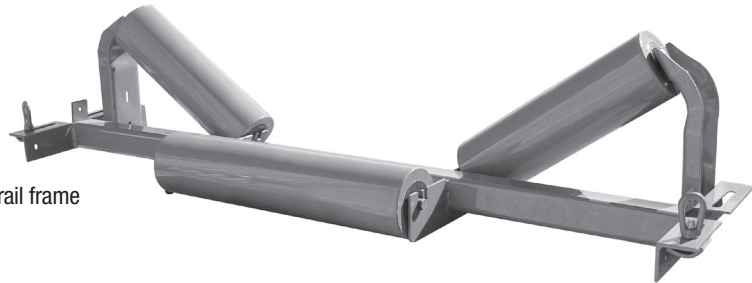

CEMA C Part Number		CEMA D Part Number		BW
5"	6"	5"	6"	
C5-35EW-24	C6-35EW-24	--	--	24
C5-35EW-30	C6-35EW-30	--	--	30
C5-35EW-36	C6-35EW-36	D5-35EW-36	D6-35EW-36	36
C5-35EW-42	C6-35EW-42	D5-35EW-42	D6-35EW-42	42
C5-35EW-48	C6-35EW-48	D5-35EW-48	D6-35EW-48	48
C5-35EW-54	C6-35EW-54	D5-35EW-54	D6-35EW-54	54
C5-35EW-60	C6-35EW-60	D5-35EW-60	D6-35EW-60	60
--	--	D5-35EW-72	D6-35EW-72	72



# Other Components Available

## Rubber Lagged Conveyor Rollers

Long lasting return roller solution in sticky material

- 60 durometer rubber hardness
- 1/4" or 1/2" rubber
- Installed on 4", 5", or 6" rolls
- SpinGuard® seal system
- 18" to 72" belt widths
- Available in CEMA C and D
- Also available installed on troughing and special application rollers

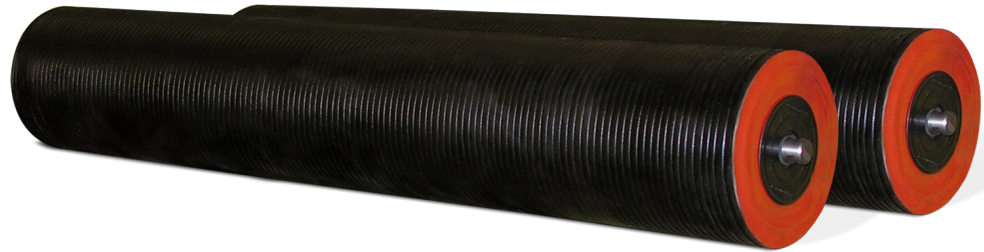

# Other Components

## Sealing System

- Keeps material from leaking out between belt and hopper skirting.
- Available in several configurations - 5" cartridges, 10" cartridges, or sealing bars available in 4' and 5' lengths.
- Lengths are flexible to customer needs.
- Takes away the sag of the belt between rolls in the conveyor load zone.

## Replacement Cartridge Part Numbers

BW	SINGLE PART NUMBERS	
	5"	6"
24	D5S-24-1	D6S-24-1
30	D5S-30-1	D6S-30-1
36	D5S-36-1	D6S-36-1
42	D5S-42-1	D6S-42-1
48	D5S-48-1	D6S-48-1
54	D5S-54-1	D6S-54-1
60	D5S-60-1	D6S-60-1
72	D5S-72-1	D6S-72-1

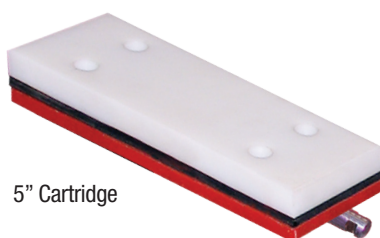

5" Cartridge

BW	DOUBLE PART NUMBERS	
	5"	6"
24	D5S-24-2	D6S-24-2
30	D5S-30-2	D6S-30-2
36	D5S-36-2	D6S-36-2
42	D5S-42-2	D6S-42-2
48	D5S-48-2	D6S-48-2
54	D5S-54-2	D6S-54-2
60	D5S-60-2	D6S-60-2
72	D5S-72-2	D6S-72-2

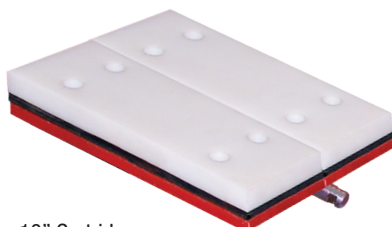

10" Cartridge

BW	SEAL BAR PART NUMBERS	
	48"	60"
24	38-000026	38-000027
30	38-000026	38-000027
36	38-000026	38-000027
42	38-000026	38-000027
48	38-000026	38-000027
54	38-000026	38-000027
60	38-000026	38-000027
72	38-000026	38-000027



Seal bar

# Other Components

## Impact Bed

Loading area support kit

CEMA C - 5" Diameter Bars				
Length	BW	20°	35°	45°
4' Impact Bed	24	I-C5204-241	I-C5354-241	I-C5454-241
	30	I-C5204-301	I-C5354-301	I-C5454-301
	36	I-C5204-361	I-C5354-361	I-C5454-361
	42	I-C5204-421	I-C5354-421	I-C5454-421
	48	I-C5204-481	I-C5354-481	I-C5454-481
	54	I-C5204-541	I-C5354-541	I-C5454-541
	60	I-C5204-601	I-C5354-601	I-C5454-601
	72	I-C5204-721	I-C5354-721	I-C5454-721
5' Impact Bed	24	I-C5205-241	I-C5355-241	I-C5455-241
	30	I-C5205-301	I-C5355-301	I-C5455-301
	36	I-C5205-361	I-C5355-361	I-C5455-361
	42	I-C5205-421	I-C5355-421	I-C5455-421
	48	I-C5205-481	I-C5355-481	I-C5455-481
	54	I-C5205-541	I-C5355-541	I-C5455-541
	60	I-C5205-601	I-C5355-601	I-C5455-601
	72	I-C5205-721	I-C5355-721	I-C5455-721

CEMA C - 6" Diameter Bars				
Length	BW	20°	35°	45°
4' Impact Bed	24	I-C6204-241	I-C6354-241	I-C6454-241
	30	I-C6204-301	I-C6354-301	I-C6454-301
	36	I-C6204-361	I-C6354-361	I-C6454-361
	42	I-C6204-421	I-C6354-421	I-C6454-421
	48	I-C6204-481	I-C6354-481	I-C6454-481
	54	I-C6204-641	I-C6354-641	I-C6454-641
	60	I-C6204-601	I-C6354-601	I-C6454-601
	72	I-C6204-721	I-C6354-721	I-C6454-721
5' Impact Bed	24	I-Cw205-241	I-C6355-241	I-C6455-241
	30	I-C6205-301	I-C6355-301	I-C6455-301
	36	I-C6205-361	I-C6355-361	I-C6455-361
	42	I-C6205-421	I-C6355-421	I-C6455-421
	48	I-C6205-481	I-C6355-481	I-C6455-481
	54	I-C6205-641	I-C6355-641	I-C6455-641
	60	I-C6205-601	I-C6355-601	I-C6455-601
	72	I-C6205-721	I-C6355-721	I-C6455-721

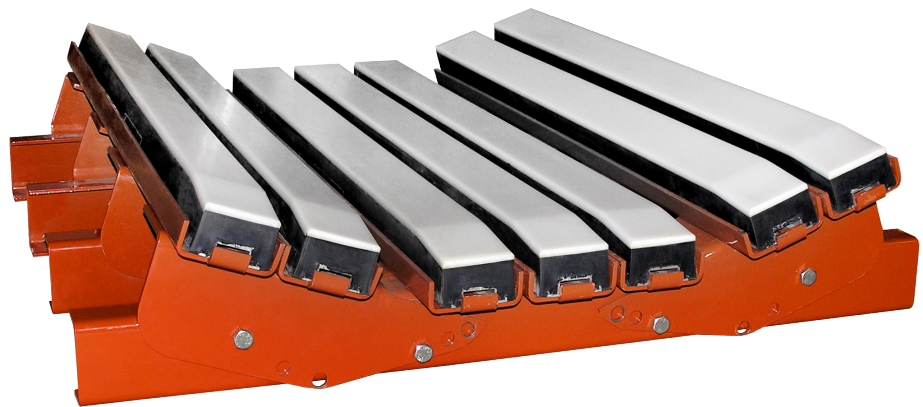

# Return & Flat Brackets Styles

## CEMA B, C, & D Return Brackets

**\*32-000019 4-1/4" Rise Bracket (2.94 lbs)**

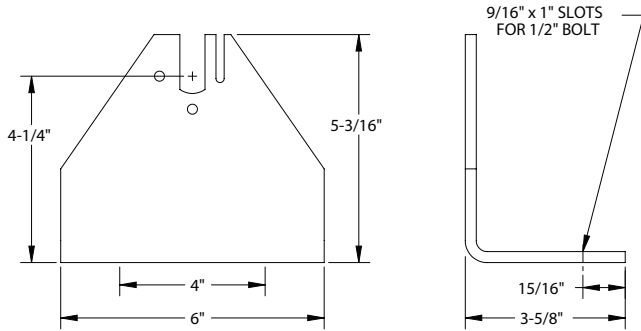

**\*32-000017 4-1/2" Drop Bracket (1.63 lbs)**

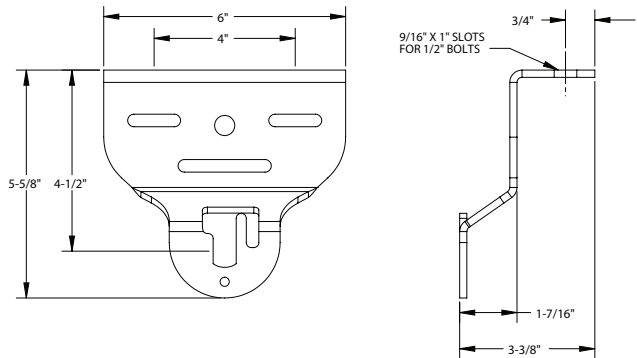

**\*32-000020 1-1/2" Rise Bracket (1.78 lbs)**

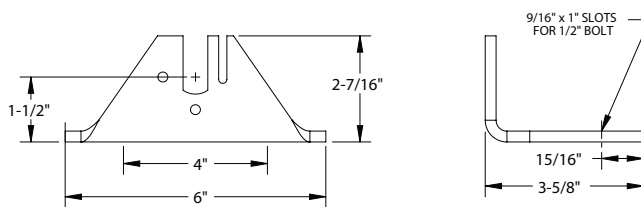

**\*32-000018 1-1/2" Drop Bracket (0.87 lbs)**

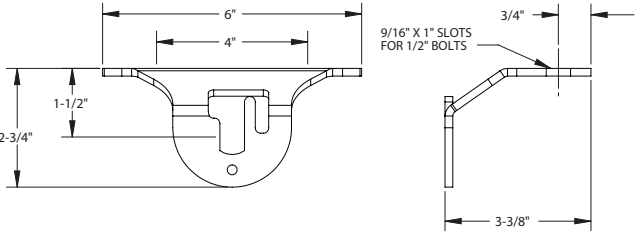

**\*32-000021 4-1/2" (2.32 lbs)**

**\*32-000022 1-1/2" (2.00 lbs)**

**Universal Return Roll Bracket**

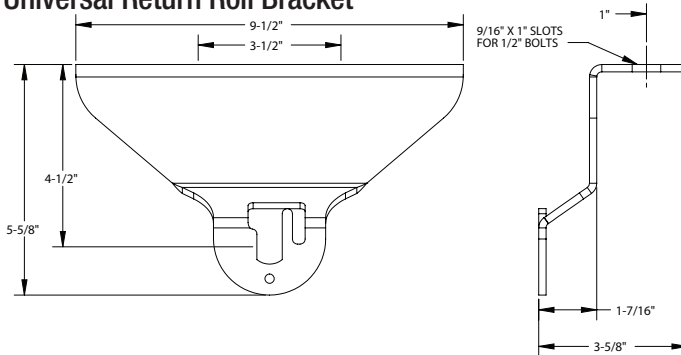

**\*32-000023 Channel Mount Bracket (2.28 lbs)**

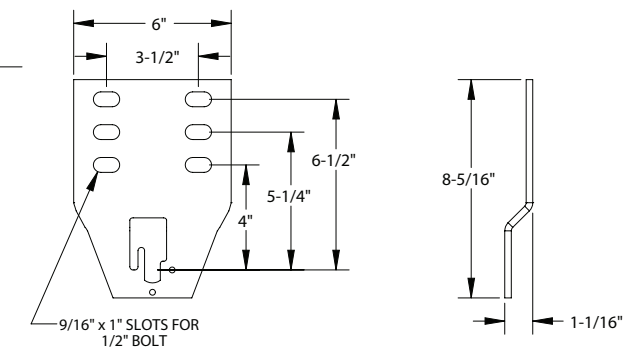

**32-010045 CEMA E Rise Bracket (7.22 lbs)**

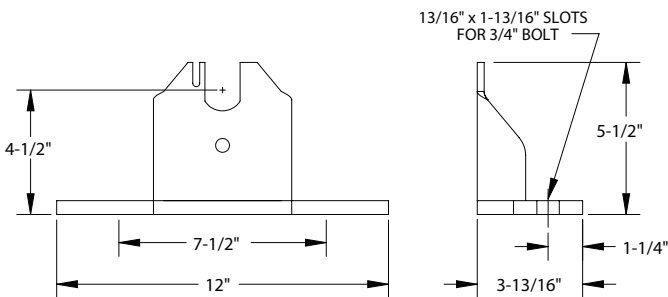

**32-010075 CEMA E 7" Drop Bracket (6.52 lbs)**

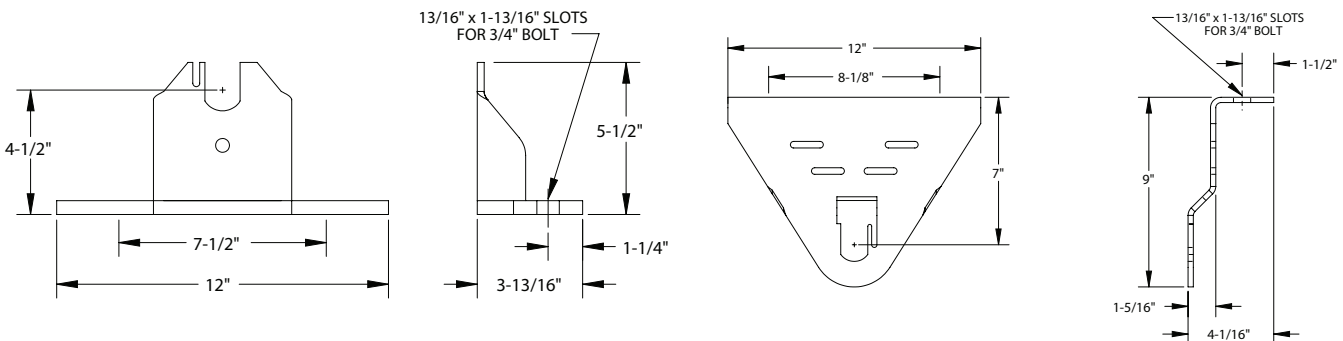

# Return & Flat Brackets Styles

## 81 & 91 SERIES BRACKETS – HEX

32-000412 4-1/4" Rise Hex Bracket (3.14 lbs)

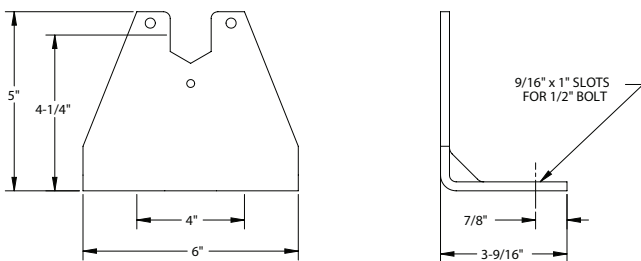

32-014046 4-1/2" Drop Hex Bracket (3.12 lbs)

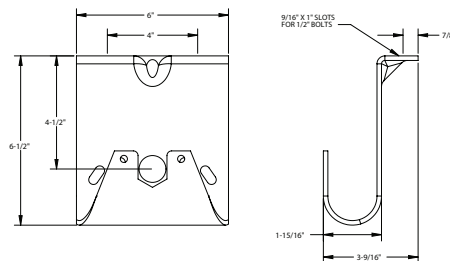

32-011608 1-1/2" Rise Hex Bracket (2.00 lbs)

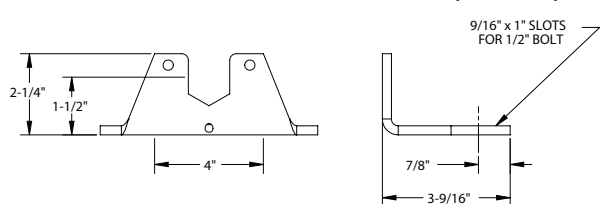

32-015120 1-1/2" Drop Hex Bracket (2.21 lbs)

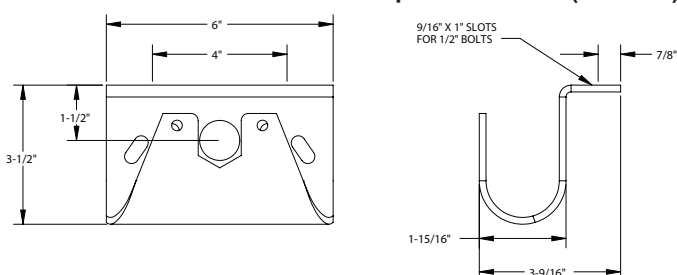

32-410450 4-1/2" CB Bracket (2.10 lbs)

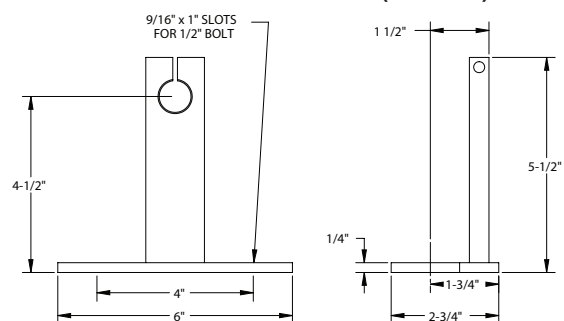

32-506000 CB Channel Mount Hex Bracket (2.00 lbs)

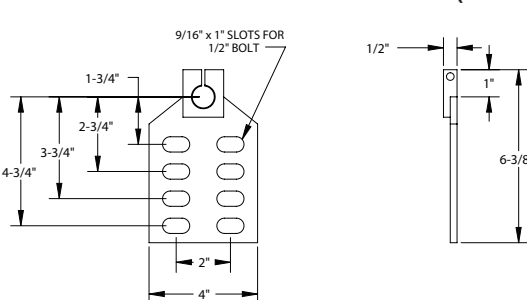

32-044081 1-1/2" CB Bracket (1.40 lbs)

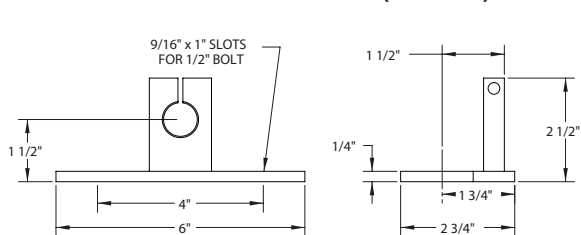

32-044080 CM Channel Mount Hex Bracket (2.00 lbs)

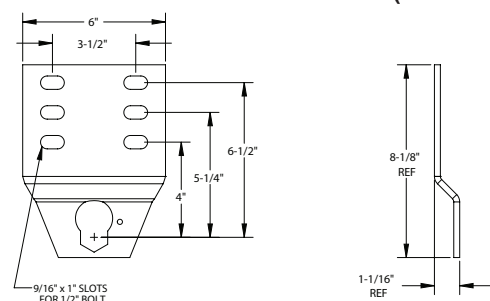

## Base Plate For CEMA B, C, D Idlers

54"-72" Belt Width CEMA C & D (2.67 lbs)

42"-48" BW CEMA B (1.34 lbs)

14"-36" BW CEMA B (0.97 lbs)

24-48 BW CEMA C & D

14"-20" BW CEMA C

3/8" PLATE SLOTS FOR 5/8" BOLT

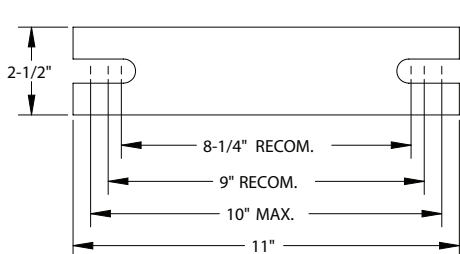

5/16" PLATE SLOTS FOR 1/2" BOLT OR 5/8" BOLT

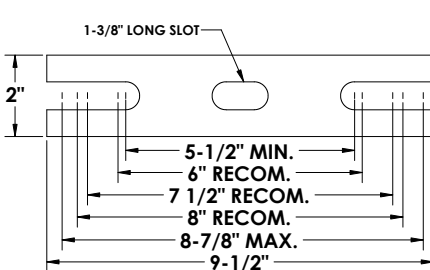

3/16" PLATE SLOTS FOR 1/2" BOLTS

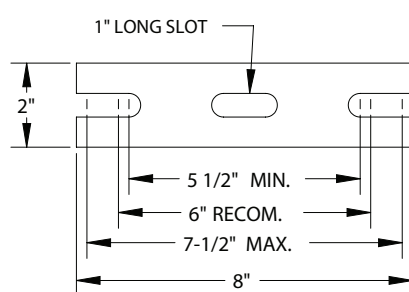

# Specialized Designs

There is no limit to the ingenuity at Superior Components. Superior realizes that each user has considerations specific to their individual applications and we are ready to customize our products for these applications.

Superior is able to modify bolt centers, roller heights, roller lengths, shaft styles, and any other idler dimension to fit your application.

To ensure the best quality on all of our conveyor components, all of our idlers are powder coated. Superior is proud to have the quickest deliveries in the industry. Whether you are in need of standard or specially designed idlers and pulleys, Superior can eliminate the hassles of finding the right component for any application. Here are just a few options customers have in custom ordering conveyor components:

- Modified bolt centers
- Neoprene & rubber coating
- Special roller lengths
- Various shaft styles
- Special dimensions
- Wire rope idlers
- Custom return rolls to fit existing brackets
- Special guide idlers
- Scale quality idlers
- Lagged Return Rollers

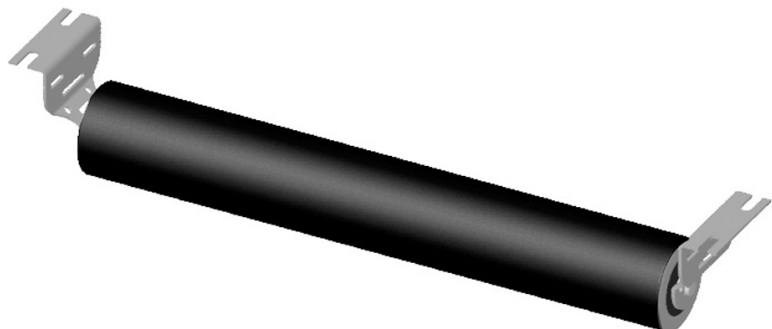
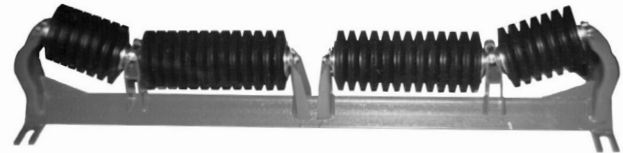
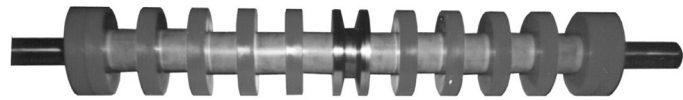
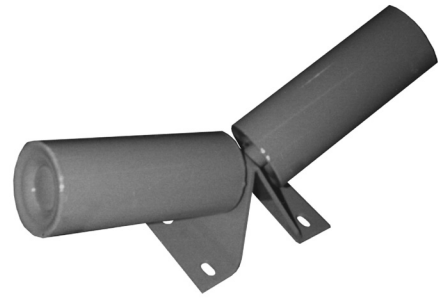
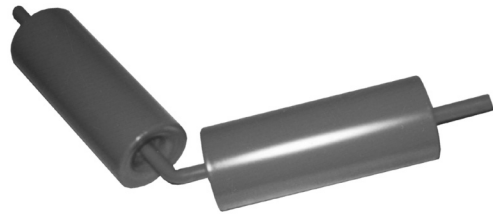

### Initial Selection; Steps 1, 2, and 3:

Select idler class by comparing calculated idler load with idler load ratings (CIL and CILR) from Tables 2-11 through 2-14. Select impact idler class, if necessary, as shown in Step 3. CEMA idler manufacturers have standard designs meeting these load ratings and dimensional standards shown in tables listed in this publication.

### Bearing L10 Life Correction; Steps 4, 5, and 6:

Factors K2 (Fig. 2.5) and K3A (Fig. 2.6) are multiplying factors used to adjust basic L10 life rating of idler class selected. Factor K2 is based on percent of idler load and K3A is factor of actual roll speed (RPM). Factor K3B (Fig. 2.7), step 5 is an optional step showing advantage of using larger diameter rolls. It can be used as a multiplier to save repeating step 5 if a larger diameter roll is used.

### Determine Potential Idler Life; Step 7:

Factors K4A (Fig. 2.8), K4B (Fig. 2.9), and K4C (Fig. 2.10) show conditions which will affect idler life and are independent of bearing L10 life, idler load and idler class. Use these figures to evaluate the potential expected idler life.

### Step No.1 Troughing Idlers Series Selection

Calculated Idler Load (lbs.) = CIL =  
 $(WB + (WM \times K1)) \times SI + IML$

Where:

WB= Belt weight (lbs./ft.) use actual or estimate from Table 2-1

WM= Material weight (lbs./ft.) =  $(Q \times 2000) / (60 \times V)$

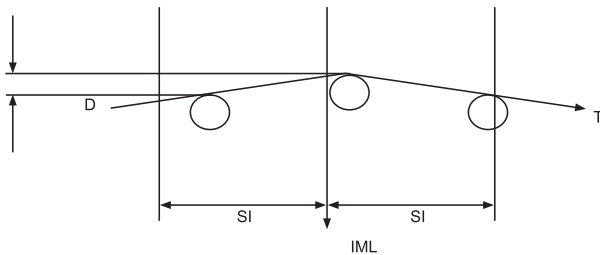

Q= Quantity of material conveyed (Tons per hour)

V= Design belt speed (FPM)

SI= Spacing of idlers (ft.)

K1= Lump adjustment factor (see Table 2-2)

Note: Actual weight of lump should be compared with WM value. In situations it may be necessary to use actual lump weight as WM.

IML= Idler misalignment load (lbs.) due to idler height deviation and belt tension =  $(D \times T) / (6 \times SI)$

Where:

D= Misalignment (inches)

T= Belt Tension (lbs.)

SI= Idler Spacing (feet)

When an idler is higher than the adjacent idler, a component of belt tension will add load to that idler. The amount of height deviation can vary with the installation and type of idler. CEMA publication on "Conveyor Installation Standards" (Appendix D, "Belt Conveyors for Bulk Material," Fifth Edition or later) lists recommendations on structure misalignment.

Use CIL and select proper series of idler from Tables 2-11 through 2-14. CIL value should be equal to or less than idler rating.

This troughing idler selection procedure for calculating idler

load does not include the following:

1. Impact force on idler at loading points.
2. Effect of belt transitions (head and tail pulley) on idler load.

**Table 2-1 WB Estimated average belt weight multiple and reduced ply belts. lbs / ft**

BELT WIDTH (inches (b))	MATERIAL CARRIED, lbs./cu. ft.		
	30-74	75-129	130-200
18	3.5	4	4.5
24	4.5	5.5	6
30	6	7	8
36	9	10	12
42	11	12	14
48	14	15	17
54	16	17	19
60	18	20	22
72	21	24	26
84	25	30	33
96	30	35	38

1. Steel cable belts increase above value by 50%.
2. Actual belt weights may vary with different constructions, manufacturers, cover gauges, etc. Use the above values for estimating. Obtain actual values from the belt manufacturer whenever possible.

**Table 2-2 K<sub>1</sub> Lump Adjustment Factor**

Material Lump Size (inches)	Material Weight, lbs./cu. ft.						
	50	75	100	125	150	175	200
4	1.0	1.0	1.0	1.0	1.1	1.1	1.1
6	1.0	1.0	1.0	1.1	1.1	1.1	1.1
8	1.0	1.0	1.1	1.1	1.2	1.2	1.2
10	1.0	1.1	1.1	1.1	1.2	1.2	1.2
12	1.0	1.1	1.1	1.2	1.2	1.2	1.3
14	1.1	1.1	1.1	1.2	1.2	1.3	1.3
16	1.1	1.1	1.2	1.2	1.3	1.3	1.3
18	1.1	1.1	1.2	1.2	1.3	1.3	1.4

### Step No. 2 Return idler Series Selection

Calculated Idler Load (lbs.) = CILR =  $(WB \times SI) + IML$

Use CILR and select proper series of idler from Tables 2-11 through 2-14. CILR should be equal to or less than return idler rating.

### Step No. 3 Impact Idler Series Selection

For homogeneous material without lumps:

Impact Force (lbs.) =  $F = (0.1389)Q\sqrt{H}$

Where:

Q= Rate of flow (ST/hr)

H= Height of fall (ft.)

The calculated impact force is then multiplied by an impact idler spacing factor, f (Table 2-3), to determine the impact force on one idler. Unit Impact Force (lbs.) =  $F_u = F(f)$

**Table 2-3 Impact Idler Spacing Factor**

SI impact	Factor f
1' 0"	0.5
1' 6"	0.7
2' 0"	0.9
>2' 0"	1

# Idler Selection Procedure

Use this unit impact force,  $F_u$ , and select proper series of impact idler from Tables 2-11 through 2-14.  $F_u$  should be equal to or less than idler rating.

For material containing large lumps:  
 Impact Force (lbs.) =  $F = W + (2kWH)^{1/2}$

Where:

W= Weight of lump (lbs.)

H= Height of fall (ft.)

k= Spring constant for specific idler type (lbs./ft.)

Use calculated energy rating, WH, and maximum lump size to select proper series of impact idler from Table 2-4. Both WH and lump size should be equal to or less than energy rating and maximum lump size.

Note: Both cases (material without lumps and material containing large lumps) should always be considered and the heavier duty idler selected to insure adequate impact resistance capabilities.

**Table 2-4 Energy Ratings for Impact Idlers**

3-Roll Rubber Impact Idlers (Equal Length Rolls)		
CEMA Series	WH (lbs.-ft.)	Maximum Lump Size (in.)
B	40	4
C	160	6
D	240	8
E	460	12

**Step No. 4 K2 = Effect of load on predicted bearing L10 life.**  
 When Calculated Idler Load (CIL) is less than CEMA load rating of series idler selected, the bearing L10 life will increase.

**Figure 2-5 Effect of Load on Predicted Bearing L10 Life**

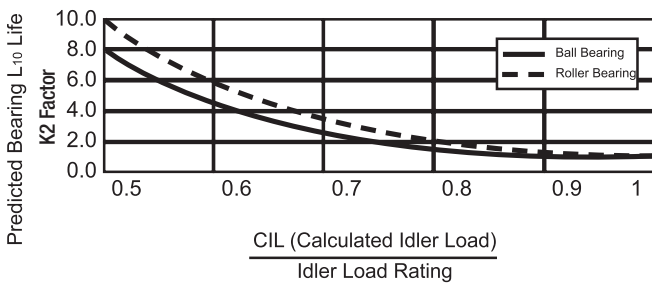

**Step No. 5 K3A = Effect of belt speed on predicted bearing L10 life**  
 CEMA L10 life ratings are based on 500 rpm. Slower speeds increase life and faster speeds decrease life. Figure 2-6 shows this relationship.

**Figure 2-6 Effect of Belt Speed on Predicted Bearing L10 Life**

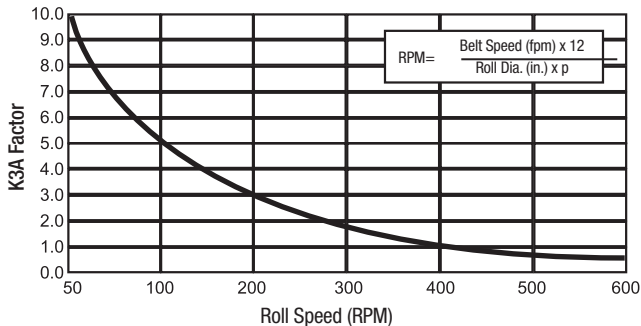

**Step No. 6 K3B= Effect of roll diameter on predicted bearing L10 life**

For a given belt speed, using larger diameter rolls will increase idler L10 life adjustments for various roll diameters using 4" diameter as a value of 1.0. Percent life increase can be calculated for each roll diameter increase.

Example: 1.5 for 6" dia. 1.25 for 5" dia.= 1.20 or 20% increase in L10 life.

**Figure 2-7 K3B= Effect of Roll Diameter on Predicted Bearing L10 Life (Based on the same belt speed)**

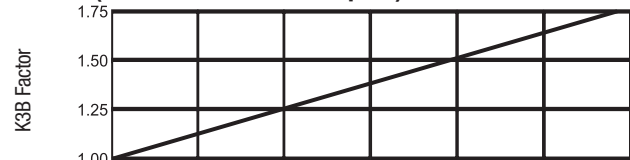

Note: In addition to increased predicted bearing L10 life, larger diameter rolls can increase idler wear life.

**Figure 2-8 K4A= Effect of maintenance on potential idler life**

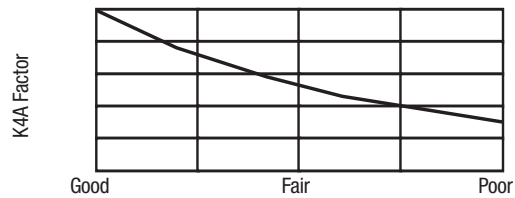

**Figure 2-9 K4B= Effect of environment on potential idler life**

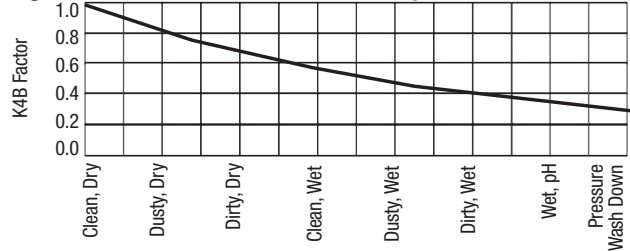

**Figure 2-10 K4C= Effect of operating temperature on potential idler life**

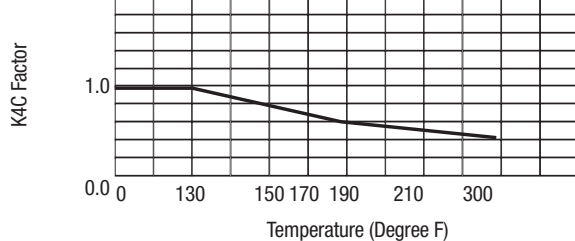

Based on collective application experience by CEMA idler manufacturers these conditions are very important in determining potential idler life. However, the exact mathematical basis is very subjective so contact your CEMA idler manufacturer for assistance or for any unusual conditions not listed.

**Figure 2-11 Load ratings for CEMA B Idlers, LBS**

BELT WIDTH (inches)	Troughed Angle			Single Roll Return
	20°	35°	45°	
18	410	410	410	220
24	410	410	410	190
30	410	410	410	165
36	410	410	396	155
42	390	363	351	140
48	381	353	342	125

Ratings based on Min. L10 of 30,000 hours at 500 RPM



# Idler Selection Procedure

Figure 2-12 Load ratings for CEMA C Idlers, LBS

BELT WIDTH (inches)	Troughed Angle			Single Roll Return	Two Roll Vee Return
	20°	35°	45°		
18	900	900	900	475	
24	900	900	900	325	500
30	900	900	900	250	500
36	900	837	810	200	500
42	850	791	765	150	500
48	800	744	720	125	500
54	750	698	675	*	500
60	700	650	630	*	500
66				*	500

Ratings based on Min. L10 of 30,000 hours at 500 RPM -  
\*CEMA D Return Idler

Figure 2-13 Load ratings for CEMA D Idlers, LBS

BELT WIDTH (inches)	Troughed Angle			Single Roll Return	Two Roll Vee Return
	20°	35°	45°		
24	1200	1200	1200	600	
30	1200	1200	1200	600	
36	1200	1200	1200	600	850
42	1200	1200	1200	500	850
48	1200	1200	1200	425	850
54	1200	1116	1035	375	850
60	1150	1070	1035	281	850
66				215	850
72	1050	977	945	155	850
78				125	850

Ratings based on Min. L10 of 60,000 hours at 500 RPM -  
\*CEMA D Return Idler

Figure 2-14 Load ratings for CEMA E Idlers, LBS

BELT WIDTH (inches)	Troughed Angle			Single Roll Return	BELT WIDTH (inches)	Troughed Angle			Single Roll Return
	20°	35°	45°			20°	35°	45°	
36	1800	1800	1800	1000	72	1800	1800	1800	700
42	1800	1800	1800	1000	78				625
48	1800	1800	1800	1000	84	1800	1674	1620	550
54	1800	1800	1800	925	90				475
60	1800	1800	1800	850	96	1750	1628	1575	400
66				775	102				250

Figure 2-15 Load ratings for CEMA F Idlers, LBS

BELT WIDTH (inches)	Troughed Angle			Single Roll Return
	20°	35°	45°	
60	3000	3000	3000	1500
72	3000	3000	3000	1200
84	3000	3000	3000	900
96	2800	2800	2800	600

CEMA D & E ratings based on Min. L10 of 60,000 hours at 500 RPM

Notes for tables 2-11 through 2-16

1. Troughing idler load ratings are for three equal length rolls.
2. Load ratings also apply for impact rolls.
3. Troughing idler load ratings are based on a load distribution of 70% on center roll and 15% on each end roll for all trough angles.

Figure 2-16 Load ratings for CEMA Picking Idlers, LBS

Belt Width	CEMA C	CEMA D	CEMA E
24	475	600	-
30	475	600	-
36	325	600	1260
42	250	600	1200
48	200	530	1000
54	150	440	1000
60	125	400	1000
66	-	-	1000
72	-	280	925
84	-	-	775
96	-	-	625

CEMA D & E ratings based on Min. L10 of 60,000 hours at 500 RPM

Figure 2-17 Load ratings for CEMA Live Shaft Idlers, LBS

Belt Width	CEMA C	CEMA D	CEMA E
18	1200	-	-
24	1200	1400	2100
30	1200	1400	2100
36	1200	1400	2100
42	1100	1400	2100
48	1000	1275	2100
54	875	1150	2100
60	780	1000	2100
72	-	850	2100
84	-	-	1825
96	-	-	1550

## Belt Carrying Capacity

The carrying capacity of a belt conveyor depends upon belt width, belt speed, and idler troughing configuration. The following information and charts will help you in selecting the proper size and style of idler.

A. Define the material and its characteristics: Refer to Table 1 for weights in Lbs per Cu. Ft. and surcharge angles for some bulk materials.

B. Select belt speed: Refer to Table 2 for maximum recommended belt speeds. The most economical selection usually dictates the use of maximum belt speeds.

C. Select required belt width: Using Table 3 and the correct surcharge angle for the material being handled, select a belt width. Table 3 gives theoretical carrying capacities with various belt widths and idler troughing angles. Table 3 is based on a belt speed of 100 FPM and a material weight of 100 lbs. Per Cu. Ft. Footnote (1) on the bottom of page 74 tells how to calculate the capacities for other belt speeds and material weights. When determining belt width, belt speed, and troughing configuration, select the narrowest belt that will handle the largest material lumps and transport the required capacity without exceeding the maximum recommended belt speed.

## Troughing Training

Self-aligning idlers operate effectively when empty belt tensions are 200-lbs./in. or less. When empty belt tensions exceed this range, the belt becomes too stiff and makes training difficult. Belt loaded at high tensions and which generate detraining forces due to off-loading cannot be re-aligned with self-aligning idlers. Self-aligning idlers work effectively at low belt tensions to overcome small amounts of idler skew, which make narrow belts easier to train. Self-aligning idlers are especially needed on low tension reversible belts. Conveyor belts that are 48" and wider usually do not need self-aligning idlers even at low belt tensions because the weight of the belt has more training force than is obtainable with a trainer.

\* The removal of one return idler on each side of a self-aligning return to increase conveyor belt wrap on the idler will increase its self-aligning capacity. An alternative in removing the return idlers is to raise the self-aligner above the return belt line.

# Idler Selection Procedure

Table 1 - Characteristics of Common Bulk Materials			
Material	Wt. in Lbs. per Cu. Ft.	Surcharge Angle in °	Maximum Conveying Angle in °
Ashes, Coal, Dry, - 3"	35-40	25-30	22
Cement, Portland	90-100	25	20
Cement, Clinker	75-80	20	18
Coal, Anthracite, Sized, 3/8" - 6"	55	12	16
Coal, Bitum., Slack	50	22	22
Coal, Bitum., ROM	50	20	18
Coke, Loose	25-30	15	20
Earth, Common, Loam, Dry	70-80	15-30	20
Earth, Clay, Dry	100-120	10-30	20
Earth, Moist	80-100	30	22
Gravel, Average, Blended	90-100	15-20	18
Gravel, Sharp	90-100	25	20
Gravel, Rounded	90-100	15	15
Iron Ore	135	20	22
Limestone, Crushed	85-90	25-30	20
Phosphate Rock	75-85	25	20
Salt, Coarse, Dry	40-45	10	20
Salt, Fine, Dry	70-80	15	22
Sand, Bank, Damp	110-120	20-30	22
Sand, Bank, Dry	90-110	10-20	15
Sand, Foundry, Shakeout	90	25	20
Sand, Silica, Dry	90-100	10-20	15
Sand, Saterated	110-130	0-15	15
Shale, Crushed	85-90	25	20
Slag, Furnace, Crushed	85-90	12	18
Slate, Crushed, - 1/2"	80-90	15	20
Soda Ash, Light	25-35	22	20
Soda Ash, Heavy	55-65	17	20
Sulphur, Crushed, - 1/2"	50-65	20	20
Sulphur, Lumpy, - 3"	80-85	25	20
Wheat	45-48	8-15	16
Wood Chips	15-25	30	25

Table 2 - Max Recommended Belt Speeds		
Material Being Conveyed	Belt Speeds (FPM)	Belt Width (in.)
Grain or other free-flowing, nonabrasive material	400	18
	600	24-30
	800	36-42
	1000	48-96
Coal, damp clay, soft ores, overburden and earth, fine-crushed stone	600	18
	800	24-36
	1000	42-60
	1200	72-96
Heavy, hard, sharp-edged ore, coarse-crushed stone	400	18
	600	24-36
	800	Over 36
Foundry sand, prepared or damp; shakeout sand with small cores, with or without small castings (not hot enough to harm belting)	350	Any Width
Prepared foundry sand and similar damp (or dry abrasive) materials discharged from belt by rubber-edged plows	200	Any Width
Nonabrasive materials discharged from belt by means of plows -except wood pulp, where 300 to 400 preferable	200	Any Width
Feeder belts, flat or troughed, for feeding fine, nonabrasive, or mildly abrasive materials from hoppers and bins.	50 to 100	Any Width

## Return Training

When self-aligning return idlers are used, they should be no closer than 12 belt widths from terminals and should not be located on vertical curves.

	Indoor	For wind and rain
In line at standard spacing *Returns removed to obtain maximum training	200 ft. 150 ft.	150 ft. 75-100 ft.

Suggested Spacing of Troughing Idlers							
Belt Width (inches)	Weight of Material Handled, lbs./cu. ft.						Return Idlers
	30	50	75	100	150	200	
18	5.5	5.0	5.0	5.0	4.5	4.5	10.0
24	5.0	4.5	4.5	4.0	4.0	4.0	10.0
30	5.0	4.5	4.5	4.0	4.0	4.0	10.0
36	5.0	4.5	4.0	4.0	3.5	3.5	10.0
42	4.5	4.5	4.0	3.5	3.0	3.0	10.0
48	4.5	4.0	4.0	3.5	3.0	3.0	10.0
54	4.5	4.0	3.5	3.5	3.0	3.0	10.0
60	4.0	4.0	3.5	3.0	3.0	3.0	10.0
72	4.0	3.5	3.5	3.0	2.5	2.5	8.0
84	3.5	3.5	3.0	2.5	2.5	2.0	8.0
96	3.5	3.5	3.0	2.5	2.0	2.0	8.0

Table 3 Maximum Belt Capacities

BELT WIDTH (inches)	Troughed Angle	Max Belt Capacity (TPH)					Max Material (inches) for 20° Surcharge	
		Surcharge Angle					All lumps uniform size	Mixed 10% lumps 90% fines
		5°	10°	20°	25°	30°		
18	20°	-	-	50	56	63	4	4
	35°	Not Recommended						
	45°	Not Recommended						
24	20°	-	-	96	108	120	5	7
	35°	-	102	122	132	142	5	7
	45°	106	115	132	140	170	5	7
30	20°	-	-	157	175	195	6	10
	35°	-	167	200	215	232	6	10
	45°	175	187	215	230	244	6	10
36	20°	-	-	230	260	290	7	12
	35°	-	248	295	318	343	7	12
	45°	258	278	318	340	360	7	12
42	20°	-	-	320	360	400	8	14
	35°	-	344	408	442	475	8	14
	45°	358	386	440	470	500	8	14
48	20°	-	-	430	480	530	10	16
	35°	-	457	540	645	630	10	16
	45°	475	510	584	623	660	10	16

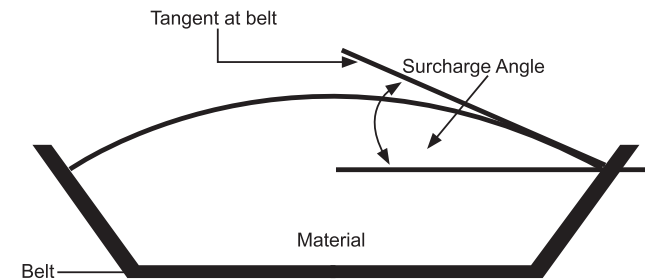

(1) All capacities shown are for material weighing 100 lbs. per cu. ft. and moving on belt 100fpm. For other weights, capacity equals table capacity.

$$\times \frac{\text{Wt./Cu. Ft.}}{100}$$

For other belt speeds, capacity equals table capacity (or calculated capacity).

$$\times \frac{\text{fpm}}{100}$$

(2) The surcharge angle is the angle formed between a horizontal line and a tangent to the material slope, both of which pass through the point where the slope meets the belt. Usually the surcharge angle is 10°-15° less than the angle of repose.

(3) "Mixed with 50% fines" means at least half of the material must be less than one half the maximum material size.

# Terms and Conditions

## SUPERIOR INDUSTRIES, LLC (d/b/a Superior Equipment and as Superior Components)

1. **OFFER AND ACCEPTANCE.** Superior Industries, LLC's ("Seller") acceptance of Buyer's order to purchase products is expressly made conditional on assent to these Terms and Conditions, which along with the Sales Order constitute a binding "Contract" between the parties. This Contract constitutes the complete and final agreement between Seller and Buyer for the products. Any additional or different terms or conditions contained in any document furnished by Buyer, including but not limited to, any purchase order or any acknowledgment, are deemed to be material and are hereby objected to and rejected by Seller. If such agreement shall be deemed an offer or counter-offer by Buyer, Seller expressly rejects such offer or counter-offer and limits acceptance to these Contract terms and expressly objects to any different or additional terms proposed by Buyer. Any actual performance by Buyer or Seller thereafter shall be deemed a renewal of the offer contained in this Contract and acceptance of this Contract without change. In the event of a conflict between the terms of this Contract and the terms of any other document, the terms of this Contract shall control. This offer to purchase Seller's products is valid for thirty (30) days from the date of the Sales Order.

2. **PAYMENT TERMS.** All prices specified in this Contract are FOB Seller's designated location which constitutes delivery. All risk of damage to or loss of the products from any cause whatsoever shall pass to Buyer upon delivery, even if Seller arranges for shipment of the product. Unless otherwise expressly provided on the reverse hereof, payment shall be made within thirty (30) days from the earlier of the date of delivery or the date of an invoice, without discount. Any discount which may be expressly provided on the reverse hereof applies to the sale price of the products at the shipping point, and does not apply to any charges made for taxes, storage, loading or transportation. All payments shall be made in United States dollars. Interest will be charged at the rate of eighteen percent (18%) per annum, or the maximum interest rate allowable by applicable law, whichever is lower, on all unpaid invoices. Buyer shall pay all taxes and charges of any nature imposed by any federal, state, or local governmental authority by reason of the sale or delivery of the products whether levied or assessed against Seller, Buyer, or the products. Such applicable taxes or charges, if not included in this Contract, shall be invoiced separately. If, in Seller's opinion, reasonable doubt exists as to Buyer's financial condition, Seller may, at any time and without prejudice to any other remedies, suspend or terminate performance of any order, decline to ship, stop any material in transit, or require full or partial payment by Seller in advance.

3. **DELIVERY.** Any delivery or promise date indicated on the Sales Order is an estimate of the date Seller believes the products will be available for delivery, provided, however, Seller shall not be responsible for any delays in delivery.

### 4. WARRANTY.

a. **Limited Warranty; Exclusion of Third Party Components.** Subject to the terms, conditions and limitations contained herein, Seller warrants only to the original Buyer that (a) Seller's new equipment products and Seller's new component products will not fail to operate in accordance with their respective specifications due to defects in material or workmanship during the period which ends two (2) years from the date of delivery, normal wear and tear excluded, and (b) Seller's new equipment products will not incur a failure of their respective structural components (i.e., trusses) due to defects in material or workmanship at any time during the period which ends five (5) years from the date of delivery, normal wear and tear excluded. The foregoing periods are sometimes referred to as "original warranty periods." The foregoing limited warranty does not apply to any part, portion or component of any product which is manufactured by a third-party ("Third-Party Component").

b. **DISCLAIMER OF ALL OTHER WARRANTIES, EXPRESS, IMPLIED OR STATUTORY.** THE LIMITED WARRANTY SET FORTH IN THE FOREGOING PARAGRAPH IS THE SOLE AND EXCLUSIVE WARRANTY WITH RESPECT TO THE PRODUCTS. SELLER MAKES NO OTHER EXPRESS WARRANTY OF ANY KIND OR NATURE AS TO THE PRODUCTS OR THEIR PERFORMANCE EXCEPT FOR THOSE LIMITED WARRANTIES EXPRESSLY SET FORTH IN THE FOREGOING PARAGRAPH AND SPECIFICALLY DISCLAIMS ANY AND ALL REPRESENTATIONS OR WARRANTIES OF ANY KIND OR NATURE CONCERNING THE PRODUCTS, INCLUDING, BUT NOT LIMITED TO, ANY REPRESENTATION OR WARRANTY THAT THE PRODUCTS COMPLY WITH ANY LAW, RULE OR REGULATION. SELLER MAKES NO WARRANTIES WITH RESPECT TO ANY THIRD PARTY COMPONENT AND SELLER SPECIFICALLY SELLS SUCH THIRD-PARTY COMPONENTS "AS IS" WITHOUT ANY WARRANTY. FURTHER, SELLER MAKES NO IMPLIED WARRANTY OF ANY KIND OR NATURE WITH RESPECT TO ITS PRODUCTS OR ANY THIRD-PARTY COMPONENT AND SPECIFICALLY DISCLAIMS ANY AND ALL IMPLIED WARRANTIES, INCLUDING, BUT NOT LIMITED TO, ANY AND ALL IMPLIED WARRANTIES OF MERCHANTABILITY, FITNESS FOR A PARTICULAR PURPOSE, NON-INFRINGEMENT, OR COMPLIANCE WITH ANY FEDERAL, STATE OR LOCAL LAW, RULE OR REGULATION. IN ADDITION, SELLER EXPRESSLY DISCLAIMS TO THE FULLEST EXTENT ALLOWED BY LAW, RULE OR REGULATION ANY WARRANTY PROVIDED UNDER ANY FEDERAL, STATE OR LOCAL LAW, RULE OR REGULATION.

c. **Terms and Conditions of Warranty; Voiding of Warranty; Notice Requirements.** The limited warranties set forth above shall be null and void if (a) any alterations or modifications are made to a product, (b) a product is not maintained in strict compliance with the maintenance requirements set forth in the maintenance manual for such product or otherwise provided to Buyer of such product, (c) any repairs are made to a product which are not authorized by Seller in writing, (d) any failure of a product to comply with the above limited warranty is not reported to Seller in writing within thirty (30) days of the date such failure first occurs, (e) a product is operated after the failure of any warranty first occurs, (f) a product is used for any purpose other than for the purpose for which it was manufactured, (g) a product is not operated in strict compliance with the terms and conditions set forth in any operating manual for the product (including but not limited to exceeding the load bearing capacity of the product), (h) a product is abused or damaged, (i) Buyer fails to deliver the product to Seller for inspection and testing if requested by Seller or Buyer disposes of the product or any part or component on or before the sixtieth (60th) day after sending a written claim under the warranty to Seller, or (j) such failure of the limited warranty results from a failure of any Third-Party Component.

d. **Course of Dealing; Course of Performance; Usage of Trade.** No course of dealing or course of performance of Seller with respect to the products sold under this Contract or with respect to any of its products to whomsoever sold and no usage of trade shall be considered in interpreting this Contract or any part thereof and none of the foregoing shall be considered a waiver or modification of any such terms, conditions, disclaimers or limitation of the limited warranties or disclaimers contained in this Contract. No statement, whether written or oral, made by any employee, sales person, distributor, agent or contractor of Seller which is not set forth in this Contract shall be considered a representation or warranty with respect to any product, its specifications or its performance and all such statements are hereby disclaimed.

e. **Exclusive Remedies for Breach of Warranty.** The sole and exclusive remedy for any failure of any product to comply with the limited warranty set forth above or any other warranty imposed upon Seller by law, if any, shall, at the election of Seller, in its sole discretion, be either (a) the repair or replacement of the product or component which failed to comply with such warranty or (b) the refund of the purchase price of the product. Buyer is responsible for all labor costs in connection with the repair or replacement of any equipment or component product; however, Seller will be responsible for its own labor performed in connection with any repair of equipment products at Seller's location. Except as provided below, any repair or replacement shall carry the same warranty as the original product but only for the remainder of the original warranty period. Buyer's exclusive remedy with respect to any claim arising out of or as a result of Third-Party Component shall be against the third-party manufacturer.

f. **Warranty Claims; Notice Requirement; Limited Time to Bring Claims.** Any and all claims under the above limited warranty shall be made to Seller only in writing and not later than thirty (30) days after the date the product first fails to comply with the above limited warranty but in no event later than the expiration of the original warranty period with respect to which the claim is being made. Any claim under the above limited warranty made after such period for making a claim shall be null and void. After receiving written notice of the warranty claim, Seller shall determine whether to (a) repair or replace the product or part or (b) refund the purchase price of the product. Seller may require Buyer to return any product or part thereof which Buyer claims to be defective to Seller at Buyer's cost for inspection as a condition to any claim under the above limited warranty. No product or part may be returned to Seller without Seller's prior written authorization. If a product which is returned is determined by Seller in its sole discretion not to have failed to comply with the limited warranty, Buyer shall pay costs of removal, repair and/or replacement for such product. If a product which is returned is determined by Seller in its sole discretion to have failed to comply with the limited warranty, Seller shall pay for all repair and/or replacement costs for such product (or refund the purchase price if so elected by Seller) and Seller shall reimburse Buyer for the reasonable costs of shipping the product or component to Seller.

# Terms and Conditions

g. **Limitation on Liability for Breach of Warranty and Other Claims.** If the warranty and the remedy for any failure of any product to comply with any warranty are deemed for any reason to fail their intended purpose, Seller's liability for any failure of any product to comply with any such warranty, together with any and all other liability, if any, arising out of or in connection with such product, including, but not limited to, all claims, whether in contract, tort, or otherwise, arising out of, connected with, or resulting from the manufacture, sale, delivery, resale, repair, replacement, or use of the product, shall not exceed the purchase price for such product. In no event shall Seller be responsible or liable to Buyer or any third party under any circumstances for any indirect, consequential, special, punitive or exemplary, damages or losses, including, but not limited to, damages for loss of profits, goodwill, use of the product or any other equipment or other intangible losses which may be incurred in connection with the product regardless of the type of claim or the nature of the cause of action, even if Seller has been advised of the possibility of such damage or loss. Any and all claims that Buyer has against Seller, whether or not Buyer is aware of such claims, must be brought by Buyer within thirty (30) days after the date that such claim first arose, but in any event within the applicable warranty period set forth above. Any claim not brought by Buyer within the applicable thirty (30) day period shall be deemed null and void.

5. **INDEMNIFICATION.** Buyer will indemnify and hold harmless Seller, its affiliates and their respective officers, directors, employees, agents and other representatives and defend any action brought against same with respect to any claims, judgments, actions, suits, demands, damages, liabilities, costs or expenses (including, but not limited to, reasonable attorneys' fees and legal expenses) associated with or arising from the ownership, use or operation of the products by Buyer or any third party, including without limitation, product liability, an international, federal or state occupational safety and health statute, or any other governmental regulations or laws.

6. **TERMINATION OF PERFORMANCE.** Buyer may cancel its order only with the written consent of Seller and upon terms that will indemnify Seller from any loss, damage and expense arising from such cancellation. Seller may terminate this Contract pursuant to Sections 2 and/or 11 hereof, and in such event, Seller shall have no further liability to produce or ship any products hereunder and shall have no liability for damages to Buyer or any third party.

7. **TECHNICAL ADVICE.** No obligation or liability shall arise out of Seller's rendering of technical advice in connection with Buyer's order of products. Any technical advice furnished, or recommendation made by Seller or any employee or representative of Seller, concerning any use or application of any products or parts furnished under this Contract is believed to be reliable, but Seller makes no warranty, express or implied, of results to be obtained. Buyer assumes all responsibility for loss or damage resulting from the handling or use of any such products or parts in accordance with such technical advice or recommendation. The selection of the products ordered, or design of any custom products, shall be Buyer's sole and ultimate responsibility, and Seller shall have no liability whatsoever for any design defects of custom products, or if the products ordered are unsuitable for Buyer's intended use. Any advice or assistance provided by Seller to Buyer in connection with Buyer's selection or design of the products is at Buyer's risk, and Seller makes no representation or warranty whatsoever in connection with such advice or assistance.

8. **ASSIGNMENT.** Buyer shall not assign its rights or obligations under this Contract without the prior written consent of Seller, which consent may be withheld for any reason in the sole discretion of Seller. Any attempt at such assignment by Buyer without the prior written consent of Seller shall be deemed null and void. This Contract will be binding upon the parties hereto, and their successors and permitted assigns.

9. **SECURITY INTEREST OF SELLER.** Title to the products will not pass to Buyer until all required payments have been made to Seller. Until the purchase price and all other applicable costs and expenses are paid in full, Seller reserves a purchase money security interest in the products and the proceeds therefrom, and Seller thereby possesses the rights of a secured party under the Uniform Commercial Code. Upon Seller's request, Buyer shall execute all necessary financing statements and other documents evidencing this security interest with the appropriate state and local authorities. Seller is entitled to and is hereby granted reasonable access to Buyer's locations as necessary to exercise its remedies as a secured party.

10. **GOVERNING LAW.** This Contract shall be construed, interpreted, and governed by the laws of the State of Minnesota without regard to its conflict of laws principles. The exclusive forum for any disputes arising out of or relating to this Contract shall be any federal or state court sitting in the State of Minnesota. The parties irrevocably consent to such exclusive jurisdiction in such courts and to the proper venue therein.

11. **FORCE MAJEURE.** Seller does not assume the risk of and shall not be liable for failure to perform any obligation relating to the products caused by civil insurrection, war, fire, strike, labor stoppages or other labor disturbances, acts of God, acts or omissions of Buyer, acts or omissions of the United States Government, floods, epidemics, freight embargoes, shortages of fuel, energy or materials, failure of suppliers or subcontractors to satisfactorily meet scheduled deliveries, or any other cause beyond the reasonable commercial control of Seller.

12. **NOTICES.** Any notices, consents or other communications required or permitted under this Contract must be in writing and delivered personally, overnight air courier, registered or certified mail or facsimile. Unless otherwise stated in this Contract, notices, consents or other communication will be deemed received (a) on the date delivered, if delivered personally or by facsimile transmission; (b) on the next business day if sent via overnight air courier; or (c) three (3) business days after being sent, if sent by registered or certified mail.

13. **SEVERABILITY; WAIVER.** The invalidity or unenforceability of any provision of this Contract shall not affect the validity or enforceability of any other provision of this Contract. No waiver of any of the provisions of this Contract shall be deemed, or shall constitute a waiver of any other provision, whether or not similar, nor shall any waiver constitute a continuing waiver. No waiver shall be binding unless executed in writing by the party making the waiver. The Section headings included herein are for the convenience of the parties only and in no way alter, modify, amend, limit or restrict the contractual obligations of the parties.

14. **NO THIRD-PARTY BENEFICIARIES; SETOFF.** Nothing in this Contract is intended to, or shall, create any third-party beneficiaries, whether intended or incidental, and neither party shall make any representations to the contrary. Seller shall have the right to deduct from any sums it owes to Buyer, any sums or the value of any obligation owed by Buyer to Seller.

15. **ENTIRE AGREEMENT.** The terms set forth herein constitute the sole terms and conditions of the Contract between Buyer and Seller. Notwithstanding the foregoing or any other term of this Contract, to the extent this Contract conflicts with the terms or conditions of any written distributor agreement between the parties, the written distributor agreement shall control. No other warranty, term, condition or understanding, whether oral or written shall be binding upon Seller, unless hereafter expressed in writing, approved and signed by Seller.

16. **SURVIVAL.** The provisions of Sections 3, 4, 5, and 7 through 16 shall survive the termination and performance of this Contract.

# Anatomy of a Superior Idler

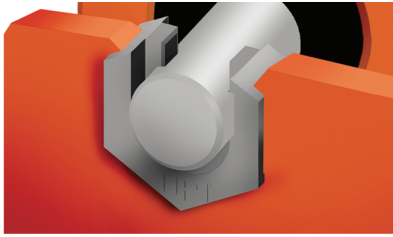

Hex Nut Adaptor

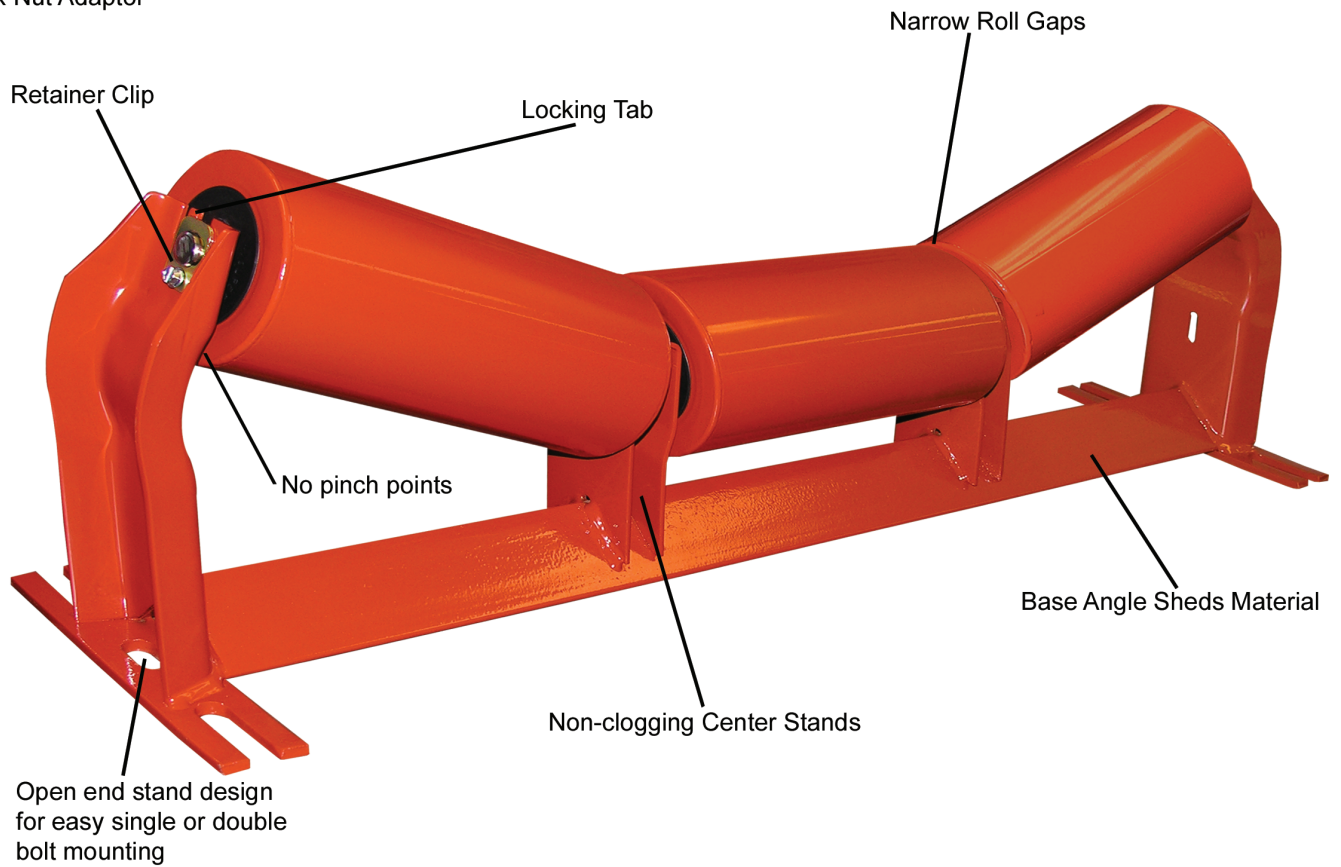



- ▶ Styles
- ▶ Ordering Guide
- ▶ Roll Interchange
- ▶ **CEMA B**
- ▶ Troughing Idlers – Equal Length Rollers
- ▶ Troughing Idlers – Rubber Cushion Impact
- ▶ Urathon® Return Roll
- ▶ Return Idlers
- ▶ Flat Idlers
- ▶ Return Idlers – Rubber Cushion
- ▶ Flat Idlers – Rubber Cushion
- ▶ Troughing Idlers – Self-Aligning
- ▶ Return Idlers – Self-Aligning
- ▶ Offset Center Roll Idlers
- ▶ Channel Mount Idlers
- ▶ Channel Mount Impact Idlers
- ▶ **CEMA C**
- ▶ Troughing Idlers – Equal Length Rollers
- ▶ Return Idlers
- ▶ Flat Idlers
- ▶ Garland Idlers
- ▶ Troughing Idlers – Rubber Cushion Impact
- ▶ Return Idlers – Rubber Cushion
- ▶ Flat Idlers – Rubber Cushion
- ▶ V-Return Idlers
- ▶ Urathon Return Rolls
- ▶ Troughing Idlers – Self-Aligning
- ▶ Return Idlers – Self-Aligning
- ▶ Troughing Idlers – Feeder / Picking
- ▶ Troughing Idlers – Unequal Length Rolls
- ▶ Offset Center Roll Idlers
- ▶ Channel Mount Idlers
- ▶ Low Profile Standard Mount
- ▶ Channel Mount Impact Idlers
- ▶ **CEMA D**
- ▶ Troughing Idlers – Equal Length Rolls
- ▶ Return Idlers
- ▶ Flat Idlers
- ▶ V-Return Idlers
- ▶ Troughing Idlers – Rubber Cushion Impact
- ▶ Return Idlers – Rubber Cushion
- ▶ Flat Idlers – Rubber Cushion
- ▶ Urathon Return Rolls
- ▶ Troughing Idlers – Self-Aligning
- ▶ Return Idlers – Self-Aligning
- ▶ Feeder / Picking Idlers
- ▶ Troughing Idlers – Unequal Length Rollers
- ▶ **CEMA E**
- ▶ Troughing Idlers – Equal Length Rollers
- ▶ Troughing Idlers – Rubber Cushion Impact
- ▶ Return Idlers – Rubber Cushion
- ▶ Troughing Idler – Self-Aligning
- ▶ Return Idlers
- ▶ Flat Idlers – Rubber Cushion
- ▶ Flat Idlers
- ▶ Return Idlers – Self-Aligning
- ▶ Urathon Return Rolls
- ▶ V-Return Idlers
- ▶ **CEMA F**
- ▶ Troughing Idlers – Equal Length Rollers
- ▶ **OTHER STYLES**
- ▶ Component Parts & Replacement Rolls
- ▶ CEMA B & C Replacement Rolls
- ▶ CEMA D & E Replacement Rolls
- ▶ 81 Series CEMA C Regreaseable Idlers
- ▶ 91 Series CEMA D Regreaseable Idlers
- ▶ Regreaseable Idler Parts
- ▶ 40 Series
- ▶ CB504 Series
- ▶ Component Accessories
- ▶ Navigator® Training Idlers
- ▶ Return Guides
- ▶ 80/81 & 90/91 Hex Style Roll Guard
- ▶ Slotted Shaft Return Guard
- ▶ Beater Bar Return Roll
- ▶ Live Shaft Rollers
- ▶ Side Guide Idlers
- ▶ Vertical Side Guide Roll
- ▶ Urethane Vertical Side Guide Roll
- ▶ Stub Roll Idlers
- ▶ Variable Pitch Idlers
- ▶ Wire Rope Pitch
- ▶ Rubber Lagged Conveyor Rollers
- ▶ Sealing System
- ▶ Impact Beds
- ▶ Return & Flat Bracket Styles
- ▶ Specialized Designs
- ▶ Idler Selection Procedure