

MHS6203 HORIZONTAL SCREEN MODULE



STANDARD FEATURES

Module Structure

- ▶ Bolt together on site, quick set up time with basic tools
- ▶ Pre-wired “plug and play” design, minimal on-site wiring
- ▶ Robust weather-protected control panel with user-friendly controls
- ▶ Galvanized steel structure including walkways, steps and guard rails
- ▶ Extra heavy-duty I-beam frame
- ▶ Rigid diagonal truss construction
- ▶ Integrated rolling chute mechanism and integrated trouser leg chutes
- ▶ CE compliant module structure and components
- ▶ Packed for container shipment for site installation and set-up

Underscreen Conveyor

- ▶ 48" (1200mm) fully skirted underscreen fines conveyor
- ▶ 15 hp (11kW) electric motor, vulcanized EP400/4+2 3-ply belt
- ▶ Direct drive motor and gearbox
- ▶ Easy access belt take-ups
- ▶ High performance belt wiper

Blending Chutes

- ▶ Replaceable, heavy-duty 3/8" (10 mm) AR 400 liners
- ▶ 4-section (25%) blending gate system for all decks
- ▶ Product combinations: bottom deck & fines; center & bottom decks; top & center decks

Terex® Cedarapids LJ-TS Horizontal Screen

- ▶ 6' x 20' (6.1m x 1.8m) 3-deck (LJ-TSH6203-32 or LJ-TSS6203-32) horizontal screen with ElJay® oval stroke design
- ▶ Three-shaft vibrator mechanism with adjustable stroke angle, stroke length, and speed
- ▶ Through-hardened forged alloy steel, high performance gear
- ▶ Patented double O-ring sealed vibrator construction
- ▶ 160 mm spherical self-aligning anti-friction roller bearings with patented flow through oil lubrication system
- ▶ Rivet bolted (cold rivet) 1/4" (6mm) thick side plate design
- ▶ 5/16" (7mm) laminated reinforcing plates
- ▶ Gland-type non-wearing shaft seal
- ▶ Crowned deck frames
- ▶ Clamp bars adjust for all wire media thickness
- ▶ Discharge lips with 1/4" (6mm) thick AR steel liners
- ▶ Bolt-on 24" (600mm) feed box with 1/4" (6mm) AR steel liners
- ▶ Heavy-duty coil spring suppression with rubber surge snubbers

Power Panel

- ▶ Electric power panel for screen and on plant collection conveyor, 50 hz standard

Off-Plant Conveyor Motor Starters

- ▶ Additional motor starters for off-plant feed conveyor up to 10 hp (7.5kW) and four product conveyors up to 10 hp (7.5kW)

SPECIFICATIONS

Terex® Minerals Processing Systems MHS6203 Horizontal Screen Module

Blending Capabilities

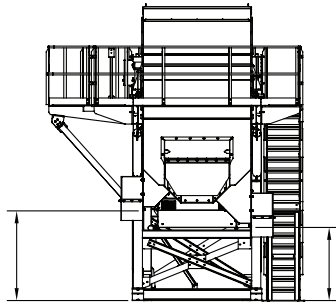
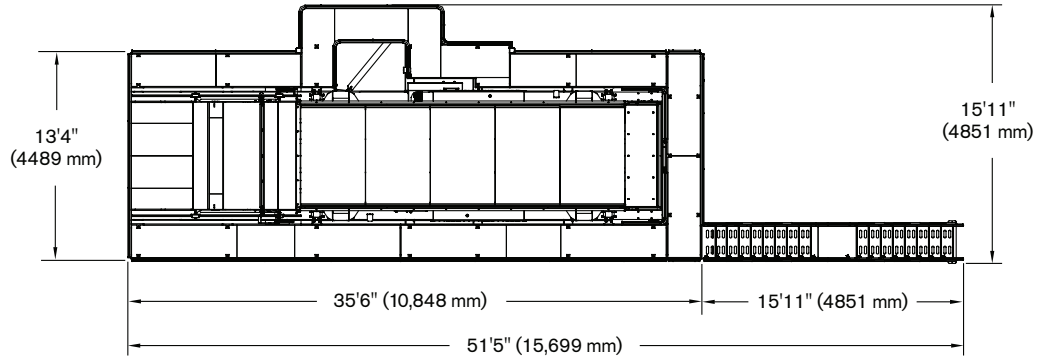
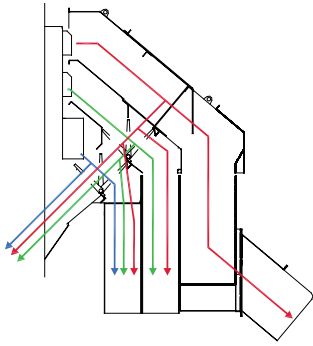

5'6" (1684 mm)
Mid Deck Chute
Discharge Height

4'6" (1372 mm)
Bottom Deck Chute
Discharge Height

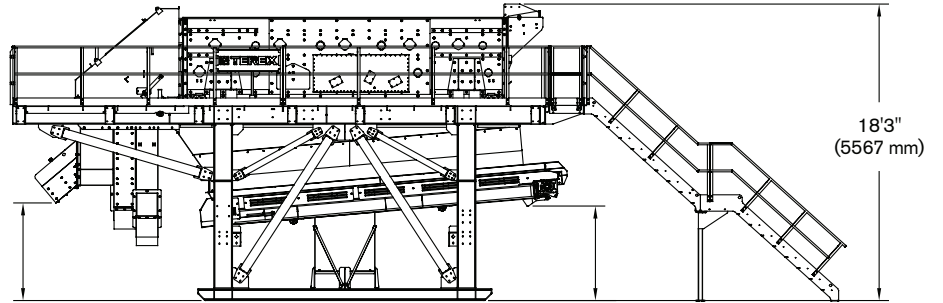

6' (1833 mm)
Top Deck Chute
Discharge Height

5'10"
(1773 mm)

MHS6203 Horizontal Screen Module Specifications	
Screen Size	6' x 20' (1829 x 6096 mm)
Screen Motor	40 hp (30 kW)
Underscreen Conveyor Width	48" (1219 mm)
Underscreen Conveyor Motor	15 hp (11 kW)
Estimated Module Weight	58,860 lbs (26,700 kg)

Access Stairs Configurations Four positions available

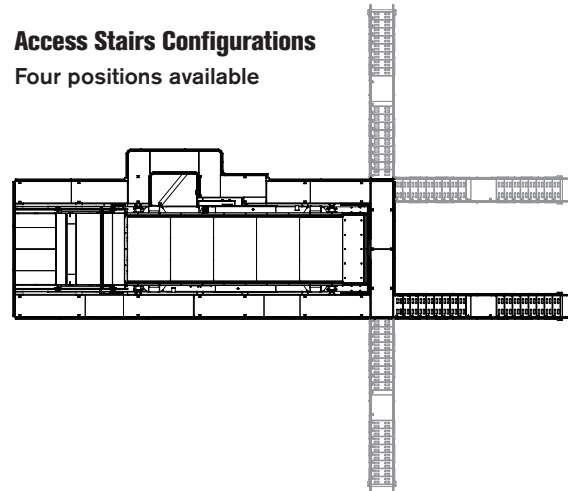

www.terexmps.com

Effective Date: November 2012. Product specifications and prices are subject to change without notice or obligation. The photographs and/or drawings in this document are for illustrative purposes only. Refer to the appropriate Operator's Manual for instructions on the proper use of this equipment. Failure to follow the appropriate Operator's Manual when using our equipment or to otherwise act irresponsibly may result in serious injury or death. The only warranty applicable to our equipment is the standard written warranty applicable to the particular product and sale and Terex makes no other warranty, express or implied. Products and services listed may be trademarks, service marks or trade-names of Terex Corporation and/or its subsidiaries in the USA and other countries. All rights are reserved. Terex is a registered trademark of Terex Corporation in the USA and many other countries. © 2012 Terex Corporation.

Terex® Minerals Processing Systems, 909 17th Street NE, Cedar Rapids, IA 52402 USA
Tel +1 319 363 3511 Fax +1 319 399 4871 www.terexmps.com

Form 25770 (11/12)



WORKS FOR YOU.™