

KOMATSU®

PC800LC-8

(SN 65001 and up)

NET HORSEPOWER
363 kW **487 HP** @ 1800 rpm

OPERATING WEIGHT
83780–87554 kg **184,705–193,025 lb**

BUCKET CAPACITY
1.70–4.50 m³ **2.25–6.0 yd³**

PC
800
LC



Photo may include optional equipment.

HYDRAULIC EXCAVATOR

WALK-AROUND

Performance Features

- **Fast Work Equipment Speed**
An arm quick-return circuit provides fast cycle times and high productivity
- **Large Digging Forces**
The new Power Max system provides increased arm and bucket digging forces
- **Heavy Lift Mode** increases lifting force by 10%
- **Two-mode Setting for Boom Control**
Operator can select powerful digging or smooth boom operation
- **Shockless Boom Control**
Operator can reduce vibration and shock while minimizing bucket spillage
- **Swing Priority Mode** provides loading efficiency at higher swing angles

Reliability Features

- **Strengthened Boom and Arm**
- **High-pressure In-line Filtration**
Each main pump has a high pressure in-line filter to provide an extra level of hydraulic system protection
- **Fuel Pre-filter** with water separator
- **O-ring Face Seals** provide excellent sealing performance for hydraulic hoses
- **Highly Reliable Electronic Devices**
Exclusively designed electronic devices have passed severe testing.
 - Controllers • Sensors • Connectors
 - Heat resistant wiring

The Super Digger

- **Powerful Digging Forces**
This optional spec with 2 arm cylinders increases arm digging force by 19% (available for the 11'10" arm only)



Maintenance Features

- **Reversible Cooling Fan**
Hydraulically-driven fan can reverse rotation to simplify cleaning the cooler assembly
- **Centralized Engine Checkpoints**
- **Slip-resistant plates for improved foot traction during maintenance**
- **Large Handrails, Steps, and Catwalk**
Wider step ladder provides easier access for machine servicing



KOMTRAX equipped machines can send location, SMR and operation maps to a secure website utilizing wireless technology. Machines also relay error codes, cautions, maintenance items, fuel levels, and much more.

NET HORSEPOWER
363 kW 487 HP @ 1800 rpm

OPERATING WEIGHT
83780 – 87554 kg
184,705 – 193,025 lb

BUCKET CAPACITY
1.70 – 4.50 m³
2.25 – 6.0 yd³

Ecology and Economy

• Low Emission Engine

A powerful, turbocharged and air-to-air aftercooled SAA6D140E-5 engine provides 363 kW **487 HP** net. This engine is EPA Tier 3 and EU Stage 3A emissions certified, without sacrificing power or productivity.

• Four-level Economy Mode Setting

Provides the operator additional flexibility to match performance to the application to optimize fuel efficiency

• Low Operational Noise

- Electronically controlled variable speed fan drive
- Large hybrid fan
- Low-noise muffler

Working Environment

• Large Comfortable Cab

- Low-noise cab design with viscous damper mounts
- Pressurized cab with large-capacity air conditioner
- High-back, heated operator seat with console-mounted armrests
- OPG top guard Level 2 (ISO 10262) capable with optional bolt-on top guard



Photo may include optional equipment.

Large TFT LCD Color Monitor

- Easy to see and use large 7" multi-function color monitor
- Can be displayed in 12 languages for global support

TFT: Thin Film Transistor LCD: Liquid Crystal Display

PERFORMANCE FEATURES



Komatsu develops and produces all major components, such as engines, electronics and hydraulic components, in house. With this “Komatsu Technology,” and adding customer feedback, Komatsu is achieving great advancements in technology. To achieve both high levels of productivity and economical performance, Komatsu has developed the main components with a total control system. The result is a new generation of high performance and environment friendly excavators.

Low Emission Engine

The Komatsu SAA6D140E-5 engine is EPA Tier 3 and EU Stage 3A emissions certified, without sacrificing power or machine productivity.



Four-level Economy Mode Setting

Provides the operator with additional flexibility to match performance to the application to optimize fuel efficiency.



Low Operational Noise

Low noise levels resulting from an electronically controlled variable speed fan drive, large hybrid fan, and low-noise muffler.

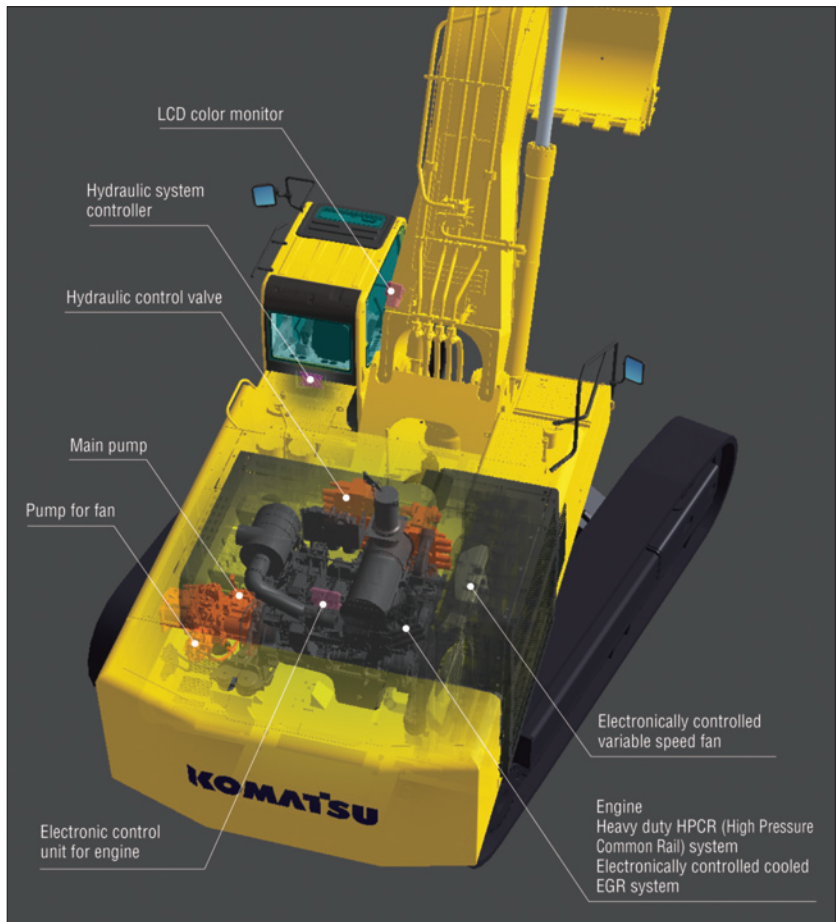

Electronically Controlled Variable Speed Fan

The electronic control system sets the revolution speed of the cooling fan according to the coolant, hydraulic oil, and ambient temperature; effectively uses the engine output to prevent wasteful fuel consumption; and reduces noise during low-speed fan revolution.

Eco-gauge that Assists Energy-saving Operations

Equipped with Eco-gauge for environment friendly energy-saving operations. By operating in the green range, CO₂ emission and fuel consumption can be reduced.



Eco-gauge

Auto Deceleration and Auto Idling Systems

The Auto Deceleration system reduces engine speed to lower fuel consumption and operating noise. The engine idling speed can be set at a lower speed through the monitor with the new auto idling system.

Working Modes Selectable

Power and Economy modes have been improved.

P mode – Power or work priority mode has low fuel consumption, but fast equipment speed and maximum power.

E mode – Economy or fuel saving mode further reduces fuel consumption, but maintains P-mode work equipment speed for light-duty applications.

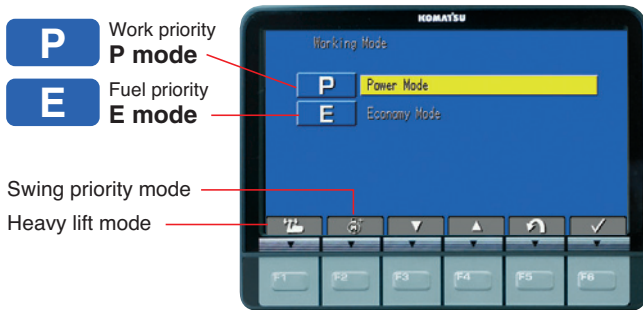

You can select Power or Economy modes using the monitor panel.

Two-mode Setting for Boom

Smooth mode provides easy operation for gathering blasted rock and scraping operations. When maximum digging force is needed, switch to **Power mode** for more effective excavating.

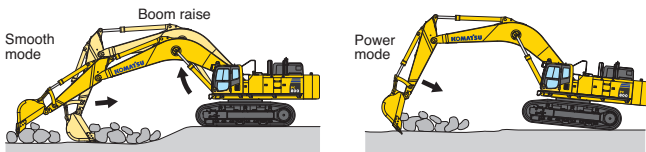

Shockless Boom Control

The PC800LC-8 boom circuit features a shockless valve (double-check slow return valve) to automatically minimize the amount of vibration present when operating the boom. Operator fatigue and bucket spillage, caused by vibration, is reduced.

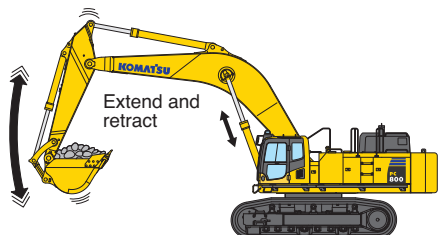

Large Digging Force

With the one-touch Power Max. function, digging force is increased. (8.5 seconds of operation)

Maximum arm crowd force (SAE):
 237 kN (24.2t) ➔ **260 kN (26.5t)** **9.7% UP**
(with Power Max.)

Maximum bucket digging force (SAE):
 296 kN (30.2t) ➔ **324 kN (33.0t)** **9.5% UP**
(with Power Max.)

*Measured with the 3600 mm 11'10" arm

Work Equipment Speed Increased

Work equipment speed becomes faster with the arm quick return circuit. This returns a portion of oil directly to the hydraulic tank during arm dump to reduce hydraulic loss and increase speed.

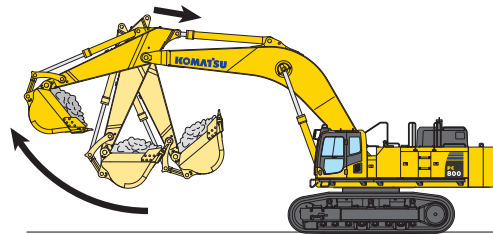

The Super Digger

Using two arm cylinders, the arm digging force is increased by 19%, providing additional breakout in hard digging applications. The Super Digger uses a standard length front, so there is no reduction in working range.



Photo may include optional equipment.

RELIABILITY FEATURES

Strengthened Boom and Arm

Thanks to large cross-sectional structures, thick high tensile strength steel plates, and partition walls, the boom and arm exhibit excellent durability and are highly resistant to bending and torsional stress.

Boom Foot Hoses

The boom foot hoses are arranged under the boom foot to reduce hose bend during operation to extend hose life.

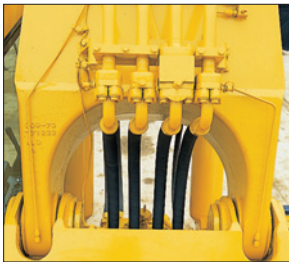

O-ring Face Seal

All hydraulic hoses use O-ring seals. This provides improved sealing performance during operation.

Frame Structure

The revolving frame and center frame swing circle mounts are one-piece non-welded structures that transmit force directly through the thick plate without passing through any welded joints.

Fuel Pre-Filter (with Water Separator)

Removes water and contaminants from the fuel to improve fuel system reliability.



High-Pressure In-line Filtration

An in-line filter in the outlet port of each main hydraulic pump provides an extra level of hydraulic system protection, reducing failures caused by contamination.

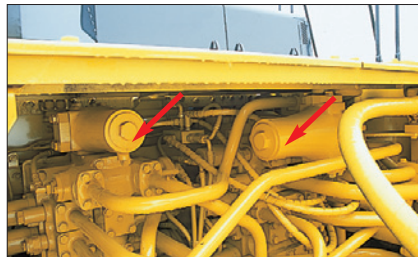

Metal Guard Rings

Metal guard rings protect all the hydraulic cylinders and improve reliability.

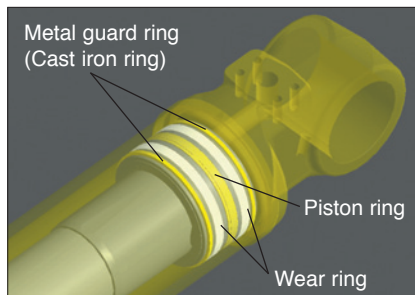

Heat-Resistant Wiring

Heat-resistant wiring is utilized for the engine electric circuit and other major component circuits.

Circuit Breaker

With a circuit breaker, the machine can be easily restarted after repair.

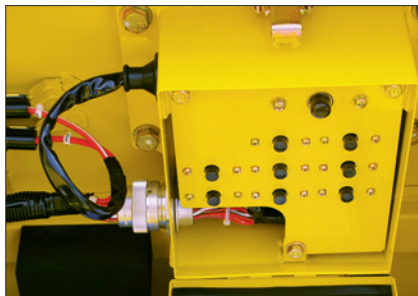

Sturdy Undercarriage

The undercarriage is strengthened to provide excellent reliability and durability when working on rocky ground or blasted rock.

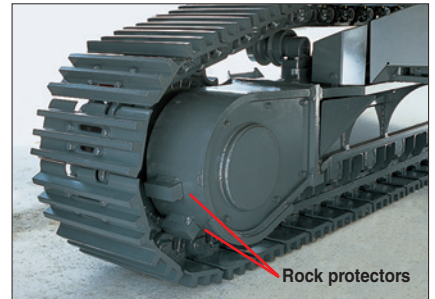

Sturdy guards shield the travel motors and piping from rock damage.

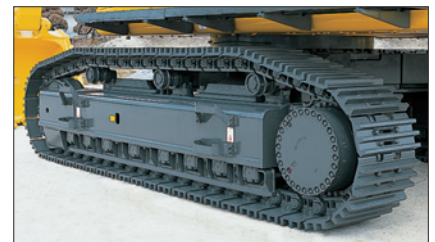

Track roller guard (full length, optional)

Strengthened Revolving Frame Underguard

Guards the machine body against rock damage and protects hydraulic components and the engine from intruding objects.

DT-Type Connectors

DT-type connectors seal tight and have high reliability.

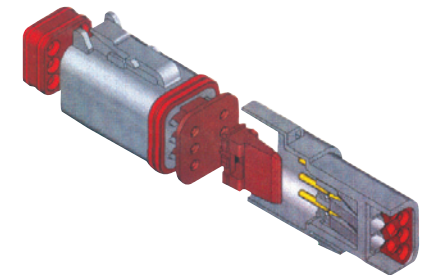

WORKING ENVIRONMENT



Photo may include optional equipment

Low Noise Design Cab

The newly designed cab is highly rigid and has excellent sound absorption ability. With improvements in noise source reduction and the use of a low noise engine, hydraulic equipment, and air conditioner, the operator can work in quiet conditions.

Wide Newly-designed Cab

The newly designed wide spacious cab includes a high-back, heated seat with a reclining backrest. The seat height and longitudinal inclination are easily adjusted using a pull-up lever. You can set the appropriate operational position of the armrest together with the console. Reclining the seat enables you to place it into a fully flat position with the headrest attached.



Seat with headrest reclined full flat

Pressurized Cab

The air conditioner, air filter and a higher internal cab air pressure (+6.0 mm Aq +0.2" Aq) minimize the amount of external dust that enters the cab.

WORKING ENVIRONMENT

Multi-position Controls

The multi-position, Proportional Pressure Control (PPC) levers allow the operator to work in comfort while maintaining precise control.

A doubleslide mechanism allows the seat and control levers to move together or independently, allowing the operator to position the controls for maximum productivity and comfort.



Seat sliding amount: 340 mm 13.4"

Low Vibration with Cab Damper Mounting

The PC800LC-8 uses viscous cab damper mounts that incorporate a longer stroke and the addition of a spring. The cab damper mounting combined with a high rigidity deck reduces vibration at the operator seat.

Automatic Air Conditioner

Allows you to easily and precisely set the cab atmosphere using the large LCD. The bi-level control function improves air flow to keep the inside of the cab comfortable throughout the year.

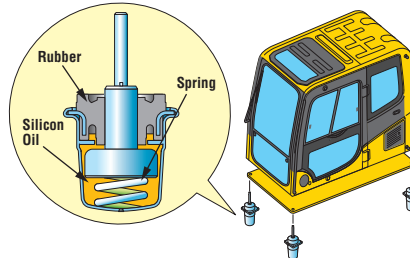
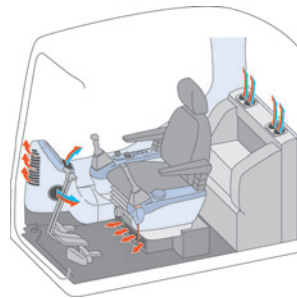

Cab Equipment



Skylight



Sliding Window and Large Side Mirror



Defroster



Cab Frame Mounted Wiper



Bottle Holder and Magazine Rack

General Features

Step Light with Timer

Provides light for about one minute to improve visibility for the operator when exiting the machine.



Pump/engine Room Partition

Separates the engine room from the hydraulic compartment.

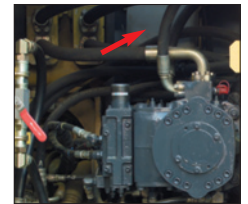

Thermal and Fan Guards

Guards are placed around high-temperature parts of the engine and fan drive.

Slip-resistant Plates

Durable slip-resistant plates maintain excellent foot traction.

Horn Interconnected with Warning Light

Provides a visual and audible notice of the excavator's operation when activated.



OPG Level 2 top guard (optional)

OPG top guard Level 2 (ISO 10262) capable with optional bolt-on top guard

Large LCD Color Monitor

Multi-Lingual LCD Monitor

A large user-friendly color monitor panel enables accurate and smooth work. The screen visibility is improved by using a TFT liquid crystal display that can be easily read at various angles and lighting conditions. All switches are simple and easy to operate, while the industry-first function keys simplify operation. The monitor displays data in 12 languages to globally support operators around the world.

Indicators

- 1 Auto-decelerator
- 2 Working mode
- 3 Travel speed
- 4 Engine water temperature gauge
- 5 Hydraulic oil temperature gauge
- 6 Fuel gauge
- 7 Eco-gauge
- 8 Function switches menu

Basic operation switches

- 1 Auto-decelerator
- 2 Working mode selector
- 3 Travel speed selector
- 4 Buzzer cancel
- 5 Wiper
- 6 Windshield washer



Mode Selection

The multi-function color monitor has Power mode (two levels), Economy mode (four levels), and Heavy Lift mode.

Working Mode	Application	Advantage
P	Power Mode	<ul style="list-style-type: none"> ● Maximum production/power ● Fast cycle time
E (E0,E1,E2,E3)	Economy Mode	<ul style="list-style-type: none"> ● Good cycle time ● Good fuel economy

Heavy Lift Mode

Gives the operator 10% more lifting force on the boom when needed for handling rock or heavy lifting applications.

Swing Priority Mode

Allows the operator to use the same easy motion for 180° loading as for 90° loading operations. By altering the oil flow, this setting allows you to select either boom or swing as the priority for increased production.

Selection	Result
ON	Oil flow to the swing motor is increased. 180° loading operations are most efficient.
OFF	Oil flow to the boom is increased. 90° loading operations are most efficient.

Rear-view Monitoring System (standard)

On the large LCD color monitor, the operator can access and view one standard camera that will display areas directly behind the machine. An optional 2-camera system is available.



MAINTENANCE FEATURES

Centralized Engine Checkpoints

Engine check points are concentrated on one side of the engine to simplify daily checks. Thermal guards are placed around high-temperature parts such as the turbocharger.



Wide Catwalk and Large Handrails

Easier operator cab access and maintenance checks.



Wide Access Steps

Allow access from the left hand catwalk to the top of the machine for engine and maintenance checks.



Long-life Oil, Filter

Uses high-performance filtering materials and long-life oil. Extends the oil and filter replacement interval.



Hydraulic oil filter (Eco-white element)

Engine oil & Engine oil filter	every 500 hours
Hydraulic oil	every 5000 hours
Hydraulic oil filter	every 1000 hours

Slip-Resistant Plates

Provided for improved foot traction.



Dust Indicator with 5-Step Indication

5-step indicator identifies air filter condition.



Reversible Cooling Fan

The hydraulically-driven fan can reverse rotation to blow out the coolers and simplify required maintenance.

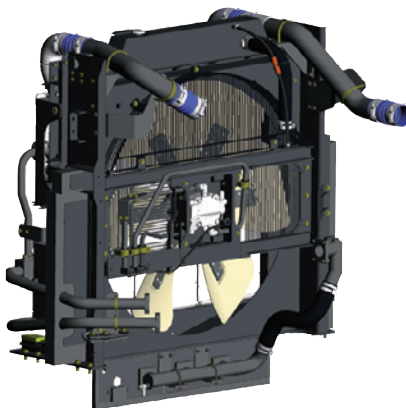

Washable Cab Floor Mat

Cab floor mat is easy to keep clean. The gently inclined surface has a flanged floor mat and drainage holes for runoff.



Electric Operated Grease Gun Equipped with Indicator

Greasing is made easy with the electric operated grease gun and indicator.

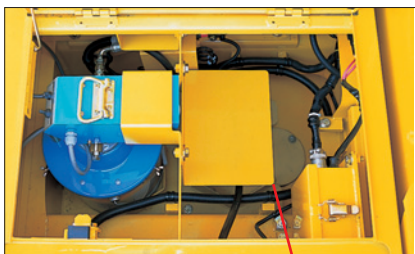

Grease can drum storage location



Grease gun

The grease gun can be reached from ground level

Indicator

Convenient Utility Space

Provides great convenience to store tools, spare parts and other supplies.



Self-Diagnostic Monitor

The PC800LC-8 features an advanced on-board diagnostics system. The Komatsu-exclusive system identifies maintenance items, reduces diagnostic times, indicates oil and filter replacement hours, and displays error codes.

Continuous Machine Monitoring

When the starting switch is turned ON, check-before-starting items and caution items appear on the LCD. If abnormalities are found, a warning lamp blinks and a warning buzzer sounds. The machine continuously runs checks to minimize the development of serious problems and allow the operator to concentrate on the work at hand.

Abnormalities Display with Code

When an abnormality occurs during operation, a user code is displayed. When an important user code is displayed, a caution lamp blinks and a warning buzzer sounds to alert the operator to take action.

Maintenance Function

When the machine exceeds the oil or filter replacement time, the maintenance monitor will display lights to inform the operator.

Trouble Data Memory Function

The monitor stores abnormality data for effective troubleshooting.

EMMS

Equipment Management Monitoring System

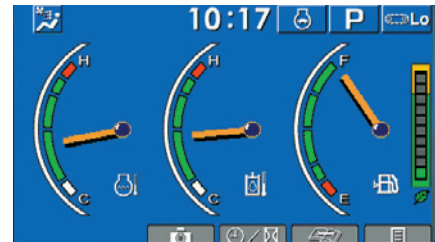

Normal display

The maintenance time display screen shows a list of maintenance items with their respective intervals and remaining hours.

	Interval	Remain
Engine Oil Change	500 h	499 h
Eng Oil Filter Change	500 h	499 h
Fuel Main Filter Change	1000 h	999 h
Fuel Pre Filter Change	500 h	499 h
Hyd Oil Filter Change	1000 h	999 h
H/Tank Breather Change	500 h	499 h

Maintenance time display

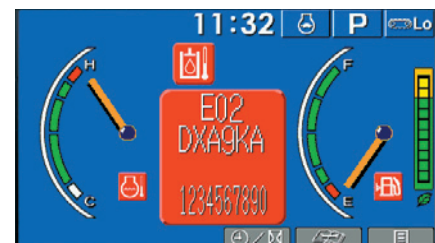

Error code display



Photo may include optional equipment.

KOMTRAX® EQUIPMENT MONITORING



KOMTRAX is Komatsu's remote equipment monitoring and management system. KOMTRAX gathers critical machine and operation information and provides it in a user-friendly format so that you can make well-informed decisions. KOMTRAX gives you more control of your equipment and better control of your business!

KOMTRAX comes standard on all new Komatsu excavators with free communications services for the first five years of ownership. It is a powerful tool and makes Komatsu excavators an even better purchase!

Fleet Optimization

KOMTRAX tells you how your machines and operators are performing. KOMTRAX provides:

- Fuel consumption data and trends, by unit or fleet
- Machine fuel level
- Machine utilization
- Actual working hours/Machine idle hours
- Attachment usage hours
- Machine travel hours
- Machine load analysis
- Operating mode ratios

Location and Asset Management

KOMTRAX tells you where your machines are and can help prevent unauthorized use. KOMTRAX provides:

- GPS location/Operation maps
- Out-of-area and movement alert with location and time
- Engine, nighttime, and calendar lock

Maintenance Management

KOMTRAX monitors the health of your machines and provides critical information so that you, and your distributor, can take proactive maintenance measures and reduce downtime. KOMTRAX provides:

- Service Meter Reading (SMR)
- Cautions/Abnormality codes
- Maintenance replacement notifications

Easy and Flexible Access to Information

With KOMTRAX, information about your machines is available anytime, anywhere. KOMTRAX provides:

- A user-friendly KOMTRAX website that provides customized access to your machine information
- E-mail and text alerts
- Web dial-up service
- Monthly fleet summary reports

For more information, ask your distributor, pick up a KOMTRAX brochure, or go to www.komatsuamerica.com/komtrax.

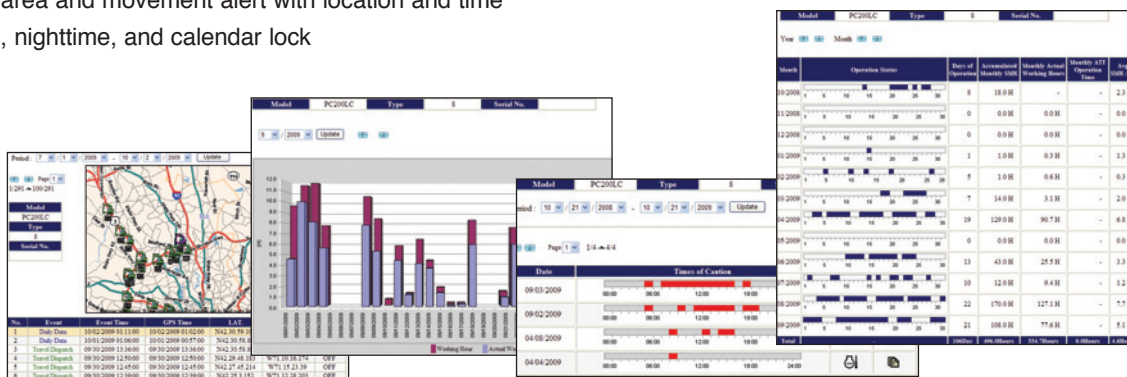

PARTS & SERVICE SUPPORT



Komatsu builds the most reliable and technologically-advanced excavators in the industry. Komatsu, and your Komatsu distributor, can provide comprehensive parts and service support during the entire life-cycle of your machine.

The Parts You Need . . . When You Need Them!

Because downtime can be costly, Komatsu makes sure that the parts you need are ready when you need them; with the same Komatsu quality and fit as the original.

To provide superior support, your local Komatsu distributor maintains an extensive supply of genuine Komatsu parts. If the part is not in stock, our integrated distributor/OEM parts network, which consists of a Master Parts Distribution Center, located in Ripley, TN



and eight regional Parts Depots, can get you any part within 24 hours. Internet parts ordering, using **e-partscentral**, allows quick and easy product purchases.

Komatsu Remanufactured Products — complete engines, transmissions, torque converters and even circuit boards — offer like-new performance, same-as-new warranties, at a significant cost reduction.

Worry-Free Ownership

At Komatsu, we work hard to help you successfully manage the complete life-cycle of your machines. Key components in achieving this goal are Komatsu Customer Support Programs (CSP's). CSP's can be customized to fit your

business plan, schedule, and budget. They let you enjoy worry-free ownership and let you get back to the job you do best — running your business.

Komatsu Oil & Wear Analysis (KOWA) assists in monitoring your machine's condition and scheduling repairs. Our new **Track Management System (TMS)** allows you to optimize the life of your undercarriage by reducing costs and extending its life.



Other CSP's address routine service requirements. From **Planned Maintenance (PM-Pro)** to **Repair & Maintenance (R&M)** contracts, Komatsu has you covered. While Komatsu's standard warranty covers your machine for 1 year with unlimited hours, our **Advantage Extended Coverage** will also add value to your investment and give you the peace of mind that unexpected repairs are covered.

By partnering with Komatsu and your local Komatsu distributor, you will get the most out of your Komatsu excavator; optimize production, minimize expense, maximize resale value, and enjoy worry-free ownership.



SPECIFICATIONS



ENGINE

Model Komatsu SAA6D140E-5
 Type 4-cycle, water-cooled, direct injection
 Aspiration Turbocharged, aftercooled, cooled EGR
 Number of cylinders 6
 Bore 140 mm **5.51"**
 Stroke 165 mm **6.50"**
 Piston displacement 15.24 ltr **930 in³**
 Governor All-speed, electronic
 Horsepower:
 SAE J1995 Gross 370 kW **496 HP**
 ISO 9249 / SAE J1349 Net 363 kW **487 HP**
 Hydraulic fan at maximum speed Net 338 kW **454 HP**
 Rated rpm 1800 rpm
 Fan drive type Hydraulic

EPA Tier 3 and EU Stage 3A emissions certified



HYDRAULIC SYSTEM

Type EOLSS (Electronic Open-center Load Sensing System)
 Number of selectable working modes 3

Main pump:

Type Two (2) variable-capacity piston pumps
 Pumps for Boom, arm, bucket, swing, and travel circuits
 Maximum flow 2 x 494 ltr/min **2 x 130.5 U.S. gal/min**

Fan drive pump Variable capacity piston type

Hydraulic motors:

Travel Two (2) axial piston motors with parking brake
 Swing Two (2) axial piston motors with swing holding brake

Relief valve setting:

Implement circuits 31.4 MPa 320 kg/cm² **4,550 psi**
 Travel circuit 34.3 MPa 350 kg/cm² **4,980 psi**
 Swing circuit 28.4 MPa 290 kg/cm² **4,120 psi**
 Heavy lift circuit 34.3 MPa 350 kg/cm² **4,980 psi**
 Pilot circuit 2.9 MPa 30 kg/cm² **430 psi**

Hydraulic cylinders:

(Number of cylinders—bore x stroke x rod diameter)
 Boom 2 – 200 mm x 1950 mm x 140 mm **7.9" x 76.8" x 5.5"**
 Arm
 Std. 1 – 200 mm x 2250 mm x 140 mm **7.9" x 88.6" x 5.5"**
 SE 2 – 185 mm x 1610 mm x 120 mm **7.3" x 63.4" x 4.7"**
 Bucket
 Std. 1 – 185 mm x 1610 mm x 130 mm **7.3" x 63.4" x 5.1"**
 SE 1 – 225 mm x 1420 mm x 160 mm **8.9" x 55.9" x 6.3"**



SWING SYSTEM

Driven method Two (2) hydraulic motors
 Swing reduction Planetary gear
 Swing circle lubrication Grease-bathed
 Swing lock Oil disc brake
 Swing speed 6.8 rpm
 Swing torque 28968 kg·m **209,461 ft. lbs.**



DRIVES AND BRAKES

Steering control Two levers with pedals
 Drive method Fully hydrostatic
 Travel motor Axial piston motor, in-shoe design
 Reduction system Planetary triple reduction
 Maximum drawbar pull 559 kN 57000 kgf **125,660 lb**
 Gradeability 70%
 Maximum travel speed
 Low 2.8 km/h **1.7 mph**
 High 4.2 km/h **2.6 mph**
 Service brake Hydraulic lock
 Parking brake Oil disc brake



UNDERCARRIAGE

Center frame H-leg
 Track frame Box-section
 Seal of track Sealed
 Track adjuster Hydraulic
 No. of shoes, each side 51
 No. of carrier rollers, each side 3
 No. of track rollers, each side 9



SERVICE REFILL CAPACITIES

Fuel tank 980 ltr **258.9 U.S. gal**
 Radiator 100 ltr **26.4 U.S. gal**
 Engine 53 ltr **14.0 U.S. gal**
 Final drive, each side 20 ltr **5.3 U.S. gal**
 Swing drive 24.5 x 2 ltr **6.5 x 2 U.S. gal**
 Hydraulic tank 470 ltr **124.2 U.S. gal**



OPERATING WEIGHT (APPROXIMATE)

Operating weight, including 8200 mm **26'11"** boom, 3600 mm **11'10"** arm, SAE heaped 3.1 m³ **4.05 yd³** backhoe bucket, operator, lubricant, coolant, full fuel tank, and standard equipment.

Double-Grouser Shoes	Operating Weight	Ground Pressure
810 mm 32"	84180 kg 185,585 lb	0.95 kg/cm ² 13.46 psi
1010 mm 40"	85579 kg 188,670 lb	0.77 kg/cm ² 10.99 psi



DIMENSIONS

	PC800LC-8			PC800LC-8 SE Spec
	8.2 m 26'11"	8.2 m 26'11"	8.2 m 26'11"	7.1 m 23'4"
Boom length	8.2 m 26'11"	8.2 m 26'11"	8.2 m 26'11"	7.1 m 23'4"
Arm length	3600 mm 11'10"	4600 mm 15'1"	5600 mm 18'4"	2945 mm 9'8"
A Overall length	14405 mm 47'3"	14435 mm 47'4"	14115 mm 46'4"	13130 mm 43'1"
B Length on ground (transport)	8105 mm 26'7"	8225 mm 27'0"	7940 mm 26'1"	7935 mm 26'0"
C Overall height (to top of boom)	4690 mm 15'5"	5630 mm 18'6"	6260 mm 20'6"	4615 mm 15'2"
D Overall width	3195 mm 10'6"			
E Overall height (to top of cab)	3570 mm 11'9"			
F Ground clearance, counterweight	1560 mm 5'1"			
G Minimum ground clearance	840 mm 2'9"			
H Tail swing radius	4400 mm 14'5"			
I Length of track on ground	5020 mm 16'6"			
J Track length	6330 mm 20'9"			
K Track gauge	3500 mm 11'6"			
L Width of crawler When retracted	4310 mm 14'2" 3590 mm 11'9"			
M Shoe width	810 mm 32"			
N Grouser height	50 mm 2.0"			
O Height (to top of exhaust)	4005 mm 13'2"			

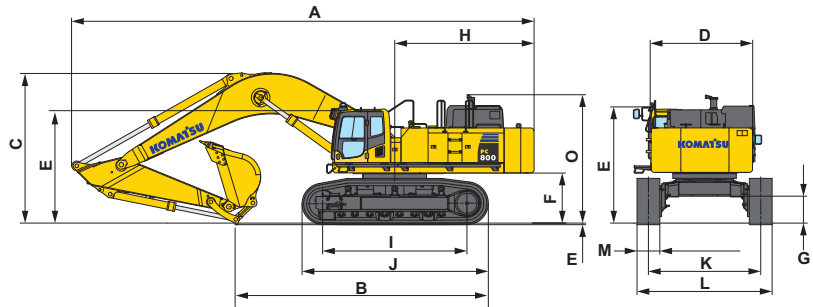

BACKHOE BUCKET, ARM, AND BOOM COMBINATION

Bucket Type	Bucket			Standard Boom Length 8200 mm 26'11"			SE Boom Length 7100 mm 23'4"
				Arm Length			SE Arm Length
	Capacity	Width	Weight	3600 mm 11'10"	4600 mm 15'1"	5600 mm 18'4"	2945 mm 9'8"
Komatsu HP	1.70 m ³ 2.23 yd ³	914 mm 36"	2544 kg 5609 lb	V	V	V	V
	2.09 m ³ 2.73 yd ³	1067 mm 42"	2732 kg 6023 lb	V	V	W	V
	2.48 m ³ 3.25 yd ³	1219 mm 48"	2998 kg 6610 lb	V	V	X	V
	2.89 m ³ 3.78 yd ³	1372 mm 54"	3190 kg 7032 lb	V	V	Y	V
	3.29 m ³ 4.31 yd ³	1524 mm 60"	3456 kg 7619 lb	V	W	Z	V
Heavy Duty Plate Lip w/ Wear Plate	3.71 m ³ 4.85 yd ³	1676 mm 66"	3652 kg 8052 lb	W	X	Z	V
	4.12 m ³ 5.39 yd ³	1829 mm 72"	3919 kg 8639 lb	X	Y	Z	V
	4.53 m ³ 5.93 yd ³	1981 mm 78"	4115 kg 9072 lb	Y	Z	Z	W
Komatsu HPS	1.70 m ³ 2.23 yd ³	914 mm 36"	2748 kg 6059 lb	V	V	V	V
	2.09 m ³ 2.73 yd ³	1067 mm 42"	2963 kg 6533 lb	V	V	X	V
	2.48 m ³ 3.25 yd ³	1219 mm 48"	3257 kg 7180 lb	V	V	Y	V
	2.89 m ³ 3.78 yd ³	1372 mm 54"	3475 kg 7662 lb	V	W	Z	V
	3.29 m ³ 4.31 yd ³	1524 mm 60"	3769 kg 8309 lb	V	X	Z	V
Heavy Duty Plate Lip & Horiz. Strips	3.71 m ³ 4.85 yd ³	1676 mm 66"	3993 kg 8802 lb	W	Y	Z	V
	4.12 m ³ 5.39 yd ³	1829 mm 72"	4286 kg 9449 lb	X	Y	Z	W
Komatsu HPX	1.70 m ³ 2.23 yd ³	914 mm 36"	2916 kg 6429 lb	V	V	V	V
	2.09 m ³ 2.73 yd ³	1067 mm 42"	3131 kg 6903 lb	V	V	X	V
	2.48 m ³ 3.25 yd ³	1219 mm 48"	3425 kg 7550 lb	V	V	Y	V
	2.89 m ³ 3.78 yd ³	1372 mm 54"	3643 kg 8032 lb	V	W	Z	V
	3.29 m ³ 4.31 yd ³	1524 mm 60"	3937 kg 8679 lb	W	X	Z	V
Severe Duty Wear Plate & Horiz. Strips & Cast Steel	3.71 m ³ 4.85 yd ³	1676 mm 66"	4160 kg 9172 lb	X	Y	Z	V
	4.12 m ³ 5.39 yd ³	1829 mm 72"	4454 kg 9819 lb	X	Y	Z	W
Shrouds							

V – Used with densities up to 3,500 lb/yd³, W – Used with densities up to 3,000 lb/yd³
 X – Used with densities up to 2,500 lb/yd³, Y – Used with densities up to 2,000 lb/yd³, Z – Not useable

SPECIFICATIONS

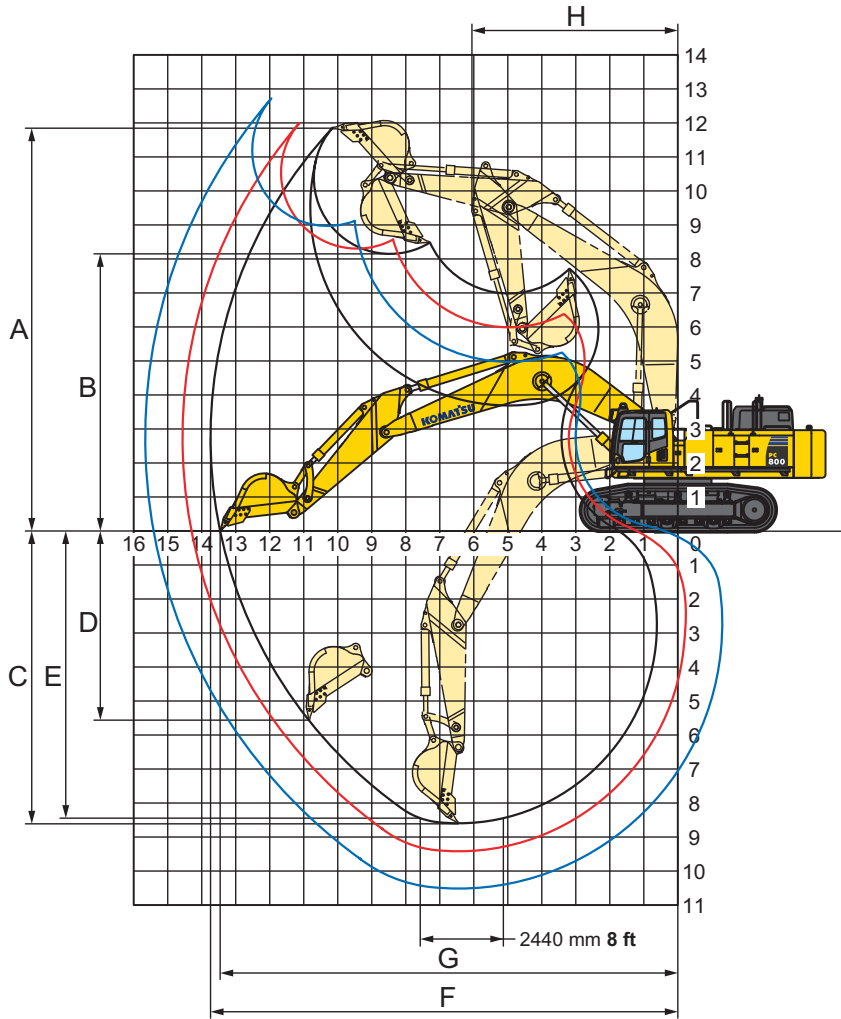

	Standard Spec			Super Digger	SE Spec
Boom length	8200 mm 26'11"			8040 mm 26'5"	7100 mm 23'4"
Arm length	3600 mm 11'10"	4600 mm 15'1"	5600 mm 18'4"	3600 mm 11'10"	2945 mm 9'8"
A Max. digging height	11840 mm 38'10"	12000 mm 39'4"	12690 mm 41'8"	11840 mm 38'10"	11330 mm 37'2"
B Max. dumping height	8145 mm 26'7"	8295 mm 27'3"	8890 mm 29'2"	8145 mm 26'7"	7525 mm 24'8"
C Max. digging depth	8600 mm 28'3"	9590 mm 31'6"	10595 mm 34'9"	8600 mm 28'3"	7130 mm 23'5"
D Max. vertical wall digging depth	5575 mm 18'3"	6575 mm 21'7"	7920 mm 26'0"	5575 mm 18'3"	4080 mm 13'5"
E Max. digging depth of cut for 8' level bottom	8445 mm 27'8"	9455 mm 31'0"	10500 mm 34'5"	8445 mm 27'8"	6980 mm 22'11"
F Max. digging reach	13740 mm 45'1"	14575 mm 47'1"	15635 mm 51'4"	13740 mm 45'1"	12265 mm 40'3"
G Max. digging reach at ground level	13460 mm 44'2"	14310 mm 46'1"	15385 mm 50'6"	13460 mm 44'2"	11945 mm 39'2"
H Min. swing radius	6060 mm 19'11"	6085 mm 20'0"	6145 mm 20'2"	6060 mm 19'11"	5645 mm 18'6"
Bucket digging force (SAE) at power max.	324 kN 33000 kgf / 72,750 lb	324 kN 33000 kgf / 72,750 lb	324 kN 33000 kgf / 72,750 lb	345 kN 35200 kgf / 77,600 lb	428 kN 43600 kgf / 96,120 lb
Arm crowd force (SAE) at power max.	260 kN 26500 kgf / 58,420 lb	233 kN 23800 kgf / 52,470 lb	198 kN 20200 kgf / 44,530 lb	312 kN 31800 kgf / 70,110 lb	363 kN 37000 kgf / 81,570 lb
Bucket digging force (ISO) at power max.	364 kN 37200 kgf / 82,010 lb	364 kN 37200 kgf / 82,010 lb	364 kN 37200 kgf / 82,010 lb	397 kN 40500 kgf / 89,290 lb	471 kN 48000 kgf / 105,820 lb
Arm crowd force (ISO) at power max.	273 kN 27900 kgf / 61,510 lb	242 kN 24700 kgf / 54,450 lb	205 kN 20900 kgf / 46,080 lb	327 kN 33300 kgf / 73,410 lb	373 kN 38100 kgf / 84,000 lb

LIFTING CAPACITIES



LIFTING CAPACITY

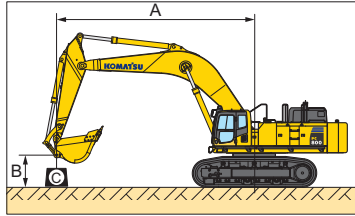

- A: Reach from swing center
- B: Bucket hook height
- C: Lifting capacity
- Cf: Rating over front
- Cs: Rating over side
- ⊗: Rating at maximum reach

Conditions:

- Arm length: 3599 mm **11'10"**
- Boom length 8200 mm **26'11"**
- Bucket 3.1 m³ **4.05 yd³** (SAE heaped)
Bucket weight: 2950 kg **6,500 lb.**
- Heavy Lift mode: On

PC800LC-8 Shoe: 810 mm 32"												Unit: kg lb	
B \ A	3.0 m 10'		4.6 m 15'		6.1 m 20'		7.6 m 25'		9.1 m 30'		⊗ Maximum		
	Cf	Cs	Cf	Cs	Cf	Cs	Cf	Cs	Cf	Cs	Cf	Cs	
9.1 m 30'											*8350	*8350	
											*18,400	*18,400	
7.6 m 25'									*12700	*12700	*8450	*8450	
									*28,100	*28,100	*18,600	*18,600	
6.1 m 20'							*16100	*16100	*13900	*13900	*8800	*8800	
							*35,500	*35,500	*30,700	*30,700	*19,400	*19,400	
4.6 m 15'					*25200	*25200	*18750	*18750	*15450	*15450	*9350	*9350	
					*55,500	*55,500	*41,300	*41,300	*34,000	*34,000	*20,600	*20,600	
3.0 m 10'					*27400	*27400	*21250	20150	*16950	15000	*10200	9200	
					*60,400	*60,400	*46,800	44,400	*37,400	33,000	*22,500	20,200	
1.5 m 4'					*28850	26800	*22950	19100	*18150	14350	*11450	9000	
					*63,200	59,000	*50,600	42,100	*40,000	31,600	*25,200	19,900	
0.0 m 0'			*15100	*15100	*27900	25950	*23700	18350	*18850	13800	*13250	9150	
			*33,300	*33,300	*61,500	57,200	*52,200	40,500	*41,500	30,500	*29,200	20,200	
-1.5 m -4'	*14100	*14100	*14250	*14250	*30650	25700	*23650	17950	*18900	13500	*14400	9650	
	*31,100	*31,100	*31,400	*31,400	*67,600	56,600	*52,200	39,600	*41,700	29,800	*31,700	21,300	
-3.0 m -10'	*16000	*16000	*24400	*24400	*29250	25850	*23000	17900	*18400	13400	*15000	10750	
	*35,300	*35,300	*53,700	*53,700	*64,500	57,000	*50,700	39,500	*40,600	29,600	*33,100	23,700	
-4.6 m -15'	*26000	*26000	*33800	*33800	*26750	25950	*21200	18150	*16750	13600	*15600	12750	
	*57,300	*57,300	*74,500	*74,500	*58,900	57,200	*46,800	40,000	*36,900	30,000	*34,500	28,200	
-6.1 m -20'			*28200	*28200	*22550	*22550	*17650	*17650			*16050	*16050	
			*62,200	*62,200	*49,700	*49,700	*38,900	*38,900			*35,400	*35,400	

PC800LC-8 Shoe: 1010 mm 40"												Unit: kg lb	
B \ A	3.0 m 10'		4.6 m 15'		6.1 m 20'		7.6 m 25'		9.1 m 30'		⊗ Maximum		
	Cf	Cs	Cf	Cs	Cf	Cs	Cf	Cs	Cf	Cs	Cf	Cs	
9.1 m 30'											*8350	*8350	
											*18,400	*18,400	
7.6 m 25'									*12700	*12700	*8450	*8450	
									*28,100	*28,100	*18,600	*18,600	
6.1 m 20'							*16100	*16100	*13900	*13900	*8800	*8800	
							*35,500	*35,500	*30,700	*30,700	*19,400	*19,400	
4.6 m 15'					*25200	*25200	*18750	*18750	*15450	*15450	*9350	*9350	
					*55,500	*55,500	*41,300	*41,300	*34,000	*34,000	*20,600	*20,600	
3.0 m 10'					*27400	*27400	*21250	20500	*16950	15450	*10200	9500	
					*60,400	*60,400	*46,800	45,200	*37,400	34,100	*22,500	21,000	
1.5 m 4'					*28650	27600	*22950	19650	*18150	14800	*11450	9350	
					*63,200	60,800	*50,600	43,400	*40,000	32,600	*25,200	20,600	
0.0 m 0'			*15100	*15100	*27900	26750	*23700	18950	*18850	14300	*13250	9500	
			*33,300	*33,300	*61,500	59,000	*52,200	41,800	*41,500	31,500	*29,200	20,900	
-1.5 m -4'	*14100	*14100	*14250	*14250	*30650	26500	*23650	18550	*18900	13950	*14400	10050	
	*31,100	*31,100	*31,400	*31,400	*67,600	58,400	*52,200	40,900	*41,700	30,800	*31,700	22,100	
-3.0 m -10'	*16000	*16000	*24400	*24400	*29250	26700	*23000	18500	*18400	13900	*15000	11150	
	*35,300	*35,300	*53,700	*53,700	*64,500	58,800	*50,700	40,800	*40,600	30,600	*33,100	24,600	
-4.6 m -15'	*26000	*26000	*33800	*33800	*26750	*26750	*21200	18750	*16750	14100	*15650	13200	
	*57,300	*57,300	*74,500	*74,500	*58,900	*58,900	*46,800	41,300	*36,900	31,000	*34,500	29,200	
-6.1 m -20'			*28200	*28200	*22550	*22550	*17650	*17650			*16050	*16050	
			*62,200	*62,200	*49,700	*49,700	*38,900	*38,900			*35,400	*35,400	

Ratings are based on SAE Standard No. J1097. Rated loads do not exceed 87% of hydraulic lift capacity or 75% of tipping load.
*Load is limited by hydraulic capacity rather than tipping.

PC800LC-8 HYDRAULIC EXCAVATOR

LIFTING CAPACITIES



LIFTING CAPACITY

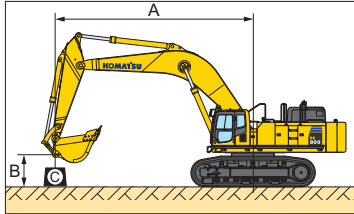

- A: Reach from swing center
- B: Bucket hook height
- C: Lifting capacity
- Cf: Rating over front
- Cs: Rating over side
- ☉: Rating at maximum reach

Conditions:

- Arm length: 4593 mm **15'1"**
- Boom length 8200 mm **26'11"**
- Bucket 2.8 m³ **3.66 yd³** (SAE heaped)
Bucket weight: 2730 kg **6,017 lb.**
- Heavy Lift mode: On

PC800LC-8 Shoe: 810 mm 32"												Unit: kg lb	
B \ A	3.0 m 10'		4.6 m 15'		6.1 m 20'		7.6 m 25'		9.1 m 30'		☉ Maximum		
	Cf	Cs	Cf	Cs	Cf	Cs	Cf	Cs	Cf	Cs	Cf	Cs	
9.1 m 30'											*7050	*7050	
											*15,500	*15,500	
7.6 m 25'											*7100	*7100	
											*15,700	*15,700	
6.1 m 20'									*12350	*12350	*7350	*7350	
									*27,200	*27,200	*16,200	*16,200	
4.6 m 15'					*21350	*21350	*16600	*16600	*13950	*13950	*7750	*7750	
					*47,000	*47,000	*36,600	*36,600	*30,800	*30,800	*17,100	*17,100	
3.0 m 10'					*24400	*24400	*19350	*19350	*15650	15100	*8350	7950	
					*53,800	*53,800	*42,700	*42,700	*34,500	*33,300	*18,500	17,500	
1.5 m 4'					*27950	27300	*21600	19350	*17150	14400	*9250	7750	
					*61,600	60,300	*47,700	42,600	*37,800	31,800	*20,400	17,100	
0.0 m 0'			*16300	*16300	*30000	26000	*23000	18350	*18200	13750	*10500	7850	
			*36,000	*36,000	*66,200	57,300	*50,700	40,500	*40,100	30,400	*23,200	17,300	
-1.5 m -4'	*12350	*12350	*15650	*15650	*30650	25300	*23400	17750	*18650	13300	*12350	8200	
	*27,300	*27,300	*34,600	*34,600	*67,500	55,700	*51,600	39,100	*41,100	29,400	*27,300	18,000	
-3.0 m -10'	*14400	*14400	*25100	*25100	*30100	25150	*23200	17450	*18550	13050	*13350	8900	
	*31,800	*31,800	*55,300	*55,300	*66,300	55,400	*51,200	38,500	*40,900	28,800	*29,500	19,600	
-4.6 m -15'	*21650	*21650	*34100	*34100	*28450	25400	*22200	17550	*17700	13100	*14050	10250	
	*47,800	*47,800	*75,200	*75,200	*62,700	56,000	*49,000	38,700	*39,100	28,900	*31,000	22,600	
-6.1 m -20'	*30450	*30450	*33000	*33000	*25400	*25400	*19950	17900	*15550	13400	*14750	12700	
	*67,100	*67,100	*72,700	*72,700	*56,100	*56,100	*44,000	39,500	*34,300	29,600	*32,500	28,100	

PC800LC-8 Shoe: 1010 mm 40"												Unit: kg lb	
B \ A	3.0 m 10'		4.6 m 15'		6.1 m 20'		7.6 m 25'		9.1 m 30'		☉ Maximum		
	Cf	Cs	Cf	Cs	Cf	Cs	Cf	Cs	Cf	Cs	Cf	Cs	
9.1 m 30'											*7050	*7050	
											*15,500	*15,500	
7.6 m 25'											*7100	*7100	
											*15,700	*15,700	
6.1 m 20'									*12350	*12350	*7350	*7350	
									*27,200	*27,200	*16,200	*16,200	
4.6 m 15'					*21350	*21350	*16600	*16600	*13950	*13950	*7750	*7750	
					*47,000	*47,000	*36,600	*36,600	*30,800	*30,800	*17,100	*17,100	
3.0 m 10'					*24400	*24400	*19350	*19350	*15650	*15650	*8350	8300	
					*53,800	*53,800	*42,700	*42,700	*34,500	*34,500	*18,500	18,300	
1.5 m 4'					*27950	*27950	*21600	20050	*17150	15000	*9250	8150	
					*61,600	*61,600	*47,700	44,200	*37,800	33,100	*20,400	18,000	
0.0 m 0'			*16300	*16300	*30000	27000	*23000	19100	*18200	14350	*10500	8200	
			*36,000	*36,000	*66,200	59,500	*50,700	42,100	*40,100	31,600	*23,200	18,100	
-1.5 m -4'	*12350	*12350	*15650	*15650	*30650	26300	*23400	18500	*18650	13900	*12350	8600	
	*27,300	*27,300	*34,600	*34,600	*67,500	58,000	*51,600	40,800	*41,100	30,600	*27,300	18,900	
-3.0 m -10'	*14400	*14400	*25100	*25100	*30100	26150	*23200	18200	*18550	13650	*13350	9350	
	*31,800	*31,800	*55,300	*55,300	*66,300	57,600	*51,200	40,100	*40,900	30,100	*29,500	20,600	
-4.6 m -15'	*21650	*21650	*34100	*34100	*28450	26400	*22200	18300	*17700	13700	*14050	10700	
	*47,800	*47,800	*75,200	*75,200	*62,700	58,200	*49,000	40,300	*39,100	30,200	*31,000	23,600	
-6.1 m -20'	*30450	*30450	*33000	*33000	*25400	*25400	*19950	18650	*15550	14000	*14750	13300	
	*67,100	*67,100	*72,700	*72,700	*56,100	*56,100	*44,000	41,100	*34,300	30,900	*32,500	29,300	

Ratings are based on SAE Standard No. J1097. Rated loads do not exceed 87% of hydraulic lift capacity or 75% of tipping load.
*Load is limited by hydraulic capacity rather than tipping.



LIFTING CAPACITY

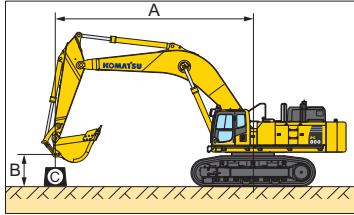

- A: Reach from swing center
- B: Bucket hook height
- C: Lifting capacity
- Cf: Rating over front
- Cs: Rating over side
- ⊗: Rating at maximum reach

Conditions:

- Arm length: 5600 mm **18'4"**
- Boom length 8200 mm **26'11"**
- Bucket 2.8 m³ **3.66 yd³** (SAE heaped)
- Bucket weight: 2730 kg **6,017 lb.**
- Heavy Lift mode: On

PC800LC-8 Shoe: 810 mm 32"												Unit: kg lb	
B \ A	3.0 m 10'		4.6 m 15'		6.1 m 20'		7.6 m 25'		9.1 m 30'		⊗ Maximum		
	Cf	Cs	Cf	Cs	Cf	Cs	Cf	Cs	Cf	Cs	Cf	Cs	
9.1 m 30'												*4650	*4650
7.6 m 25'												*10,300	*10,300
6.1 m 20'												*4750	*4750
4.6 m 15'									*11550	*11550	*5000	*5000	
3.0 m 10'					*22450	*22450	*17000	*17000	*13900	*13900	*5350	*5350	
1.5 m 4'					*26650	*26650	*19600	19300	*15600	14500	*5850	*5850	
0.0 m 0'			*16900	*16900	*29100	26200	*21550	18400	*17000	13700	*6550	6450	
-1.5 m -4'	*10400	*10400	*14700	*14700	*29950	25050	*22550	17550	*17850	13100	*7550	6650	
-3.0 m -10'	*11400	*11400	*20050	*20050	*29850	24500	*22750	17050	*18100	12700	*9050	7150	
-4.6 m -15'	*19700	*19700	*27750	*27750	*29050	24500	*22350	16900	*17800	12550	*11400	8050	
-6.1 m -20'	*27550	*27550	*33300	*33300	*27050	24850	*21000	17100	*16600	12700	*12550	9600	

PC800LC-8 Shoe: 1010 mm 40"												Unit: kg lb	
B \ A	3.0 m 10'		4.6 m 15'		6.1 m 20'		7.6 m 25'		9.1 m 30'		⊗ Maximum		
	Cf	Cs	Cf	Cs	Cf	Cs	Cf	Cs	Cf	Cs	Cf	Cs	
9.1 m 30'												*4650	*4650
7.6 m 25'												*10,300	*10,300
6.1 m 20'												*4750	*4750
4.6 m 15'									*11550	*11550	*5000	*5000	
3.0 m 10'					*22450	*22450	*17000	*17000	*13900	*13900	*5350	*5350	
1.5 m 4'					*26650	*26650	*19600	*19600	*15600	15100	*5850	*5850	
0.0 m 0'			*16900	*16900	*29100	27200	*21550	19150	*17000	14300	*6550	*6550	
-1.5 m -4'	*10400	*10400	*14700	*14700	*29950	26050	*22550	18300	*17850	13650	*7550	7050	
-3.0 m -10'	*11400	*11400	*20050	*20050	*29850	25500	*22750	17750	*18100	13250	*9050	7550	
-4.6 m -15'	*19700	*19700	*27750	*27750	*29050	25500	*22350	17650	*17800	13150	*11400	8450	
-6.1 m -20'	*27550	*27550	*33300	*33300	*27050	25500	*21000	17850	*16600	13300	*12550	10050	

Ratings are based on SAE Standard No. J1097. Rated loads do not exceed 87% of hydraulic lift capacity or 75% of tipping load.
 *Load is limited by hydraulic capacity rather than tipping.



STANDARD EQUIPMENT

ENGINE AND RELATED ITEMS:

- Air cleaner, double element, dry type
- Engine, Komatsu SAA6D140E-5
- Fuel pre-filter (10 micron) with water separator
- Fuel primary filter (2 micron)
- Variable speed cooling fan, hydraulic drive, reversible

ELECTRICAL SYSTEM:

- Alternator, 90 amp, 24V
- Auto decelerator
- Batteries, 220 Ah, 2 x 12V
- Horn, electric
- Interconnected horn and warning light
- Power supply, 12V
- Starting motor, 11kW
- Step light with timer
- Work lights-2 boom, 2 cab top front, 1 cab bottom

UNDERCARRIAGE:

- 810 mm **32"** double grouser
- 9 track/3 carrier rollers (each side)
- Hydraulic track adjusters (each side)
- Variable track gauge
- Sealed track

GUARDS AND COVERS:

- Radiator and oil cooler with net
- Engine thermal guards and fan guard
- Pump/engine room partition cover
- Revolving frame undercover
- Track frame center undercover (center)
- Travel motor guards

OPERATOR ENVIRONMENT:

- Damper mount, all-weather, sound-suppressed cab with tinted safety glass windows, lockable door, intermittent window wiper and washer, floor mat, cigarette lighter and ashtray, automatic air conditioner, AM-FM radio, seat belt (retractable) 78 mm **3"**
- Multi-function color monitor, full control dial, service meter, gauges (coolant temperature, hydraulic oil temperature and fuel level), caution lights (electric charge, engine oil pressure, and air cleaner clogging), indicator lights (engine preheating and swing lock), level check lights (coolant and engine oil level), self-diagnostic system with trouble data memory
- High-back suspension seat, heated

- Cab with pull-up type front window
- Rear-view mirrors (RH & LH)
- Rear-view camera (1)
- Operator Protective Guard (OPG), Level 1 top guard

HYDRAULIC CONTROLS:

- Fully hydraulic, with Electronic Open-Center Load-Sensing (EOLSS) and engine speed sensing (pump and engine mutual control system)
- Boom and arm holding valves (8200 mm **26'11"** std. boom only)
- Control levers, wrist control levers for arm, boom, bucket, and swing with PPC system
- Control levers and pedals for steering and travel with PPC system
- In-line high-pressure filters
- Heavy lift mode system
- One axial piston motor per track for travel with counter balance valve
- Power maximizing system
- Shockless boom control
- Swing priority selection system
- Two-mode setting for boom
- Two axial piston motors for swing with single-stage relief valve
- Two control valves, 5+4 spools (boom, arm, bucket, swing, travel)
- Two variable capacity piston main pumps
- Working modes (Power & Economy w/4 settings)

DRIVE AND BRAKE SYSTEM:

- Brakes, hydraulic lock travel brakes, oil disc parking
- Hydrostatic two travel speed system with planetary final drive

OTHER STANDARD EQUIPMENT:

- Automatic swing holding brake
- Auxiliary pump drive
- Catwalk and handrails
- Corrosion resistor
- Counterweight, 13600 kg **29,975 lb**
- Grease gun, electric pump w/indicator
- KOMTRAX
- Large handrails
- Lift capacity chart
- Marks and plates, English
- One-touch engine oil drainage
- Paint, Komatsu standard
- PM tune-up service connector
- Slip-resistant plates
- Travel alarm



OPTIONAL EQUIPMENT

- | | | |
|--|---|--|
| <ul style="list-style-type: none"> ● Arms: <ul style="list-style-type: none"> — 3600 mm 11'10" std. arm assembly — 3600 mm 11'10" Super Digger arm assembly — 4600 mm 15'1" arm assembly — 5600 mm 18'4" arm assembly — 2945 mm 9'8" SE arm assembly | <ul style="list-style-type: none"> ● Booms: <ul style="list-style-type: none"> — 8200 mm 26'11" std. boom assembly — 8040 mm 26'5" Super Digger boom assembly — 7100 mm 23'4" SE boom assembly ● Additional rear-view camera (1) RH side ● Counterweight removal device ● Full length track roller guard | <ul style="list-style-type: none"> ● OPG front guard, Level 2 ● OPG top guard, Level 2 ● Rain visor ● Shoes: <ul style="list-style-type: none"> — 1010 mm 40" double grouser ● Service valve (removes holding valves) ● Sun visor |
|--|---|--|

AESS799-01

©2011 Komatsu Printed in USA

D02(1.5M)OSP

2/11 (EV-1)

KOMATSU®