



Terex® Minerals Processing Systems

Terex® Simplicity TXW620HT | Horizontal Twin Screw Wash Plant



# TXW620HT

6' x 20' HORIZONTAL  
TWIN SCREW WASH PLANT

**Terex® Simplicity TXW620HT | 6' x 20' Horizontal Twin Screw Wash Plant**

- 6' x 20' Triple Shaft Horizontal three deck screen with complete spray system.
- Portable chassis made using heavy-duty I-beam construction with four cribbing support legs with two manual landing jacks for easy truck removal. Chassis includes a triple axle suspension, twelve (12) 11:00 x 22.5 x 12 ply tires, mounted on 10-hole Budd wheels, 5th wheel, air brakes on two axles, mud flaps and tail lights.
- The unit shall include a 50 HP 1200 rpm, TEFC electric motor for screen drive and walkway access around three sides of the screen with an access ladder.
- The under-screen fines collection flume made using ¼" plate with splash-type spray system. Water spray system on all screen decks, flume and washout.
- 36" x 25' Twin Screw with two 15 HP drives.
- Standard hinged slurry box with spray bar, manifold with the necessary hardware, valves and hoses.
- Heavy-duty discharge chute made from ½" plate and lined with A.R. plate in heavy wear areas. The discharge chute includes a top deck over chute with discharge to the front of the plant. The middle deck chute discharges to the side, the bottom deck chute discharges to a 24" cross conveyor. (Optional 24" cross conveyors available for 2nd deck.)
- All standard guards provided. NOTE: Terex Simplicity does not warrant that our guards will meet all local codes. It is the responsibility of the end user to have them checked by a local inspector.
- Unit to be painted Terex White.
- Optional electrical switchgear available upon request.
- NOTE: Dimensions and specifications are subject to change without notice.



Travel Height	14' 8"
Travel Width	13' 1"
Travel Length	46' 6"
King Pin Weight	22,750 lbs.
Tri-Axle Suspension Weight	46,000 lbs.
Total Weight	69,750 lbs.

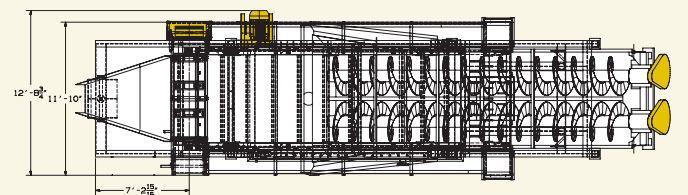
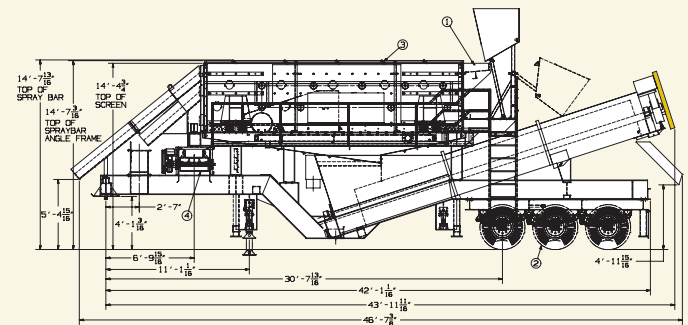
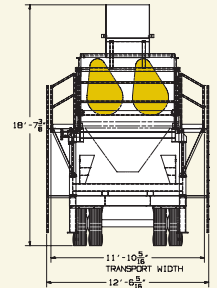

Effective Date: March, 2010. Product specifications and prices are subject to change without notice or obligation. The photographs and/or drawings in this brochure are for illustrative purposes only. Refer to the appropriate Operator's Manual for instructions on the proper use of this equipment. Failure to follow the appropriate Operator's Manual when using our equipment or to otherwise act irresponsibly may result in serious injury or death. The only warranty applicable to our equipment is the standard written warranty applicable to the particular product and sale and Terex makes no other warranty, express or implied. Products and services listed may be trademarks, service marks or trade-names of Terex Corporation and/or its subsidiaries in the USA and other countries and all rights are reserved. Terex is a registered trademark of Terex Corporation in the USA and many other countries. Copyright © 2010 Terex Corporation.