

# KOMATSU®

## WA320-7

Tier 4 Interim Engine

# WA320

### NET HORSEPOWER

165 HP @ 2100 rpm  
123 kW @ 2100 rpm

### OPERATING WEIGHT

33,731–33,984 lb  
15,300–15,415 kg

### BUCKET CAPACITY

3.7–4.2 yd<sup>3</sup>  
2.8–3.2 m<sup>3</sup>



PHOTOS MAY INCLUDE OPTIONAL EQUIPMENT

WA320

# WALK-AROUND

WA320-7



Photos may include optional equipment

# WA320-7

## Tier 4 Interim Engine

### NET HORSEPOWER

165 HP @ 2100 rpm  
123 kW @ 2100 rpm

### OPERATING WEIGHT

33,731–33,984 lb  
15300–15415 kg

### BUCKET CAPACITY

3.7–4.2 yd<sup>3</sup>  
2.8–3.2 m<sup>3</sup>



## HIGH PRODUCTION WITH LOW FUEL CONSUMPTION

### Hydrostatic Transmission:

- Quick Acceleration
- Dynamic Braking
- Variable Speed Traction Control
- Creeping Mode

**Komatsu SmartLoader Logic** helps reduce fuel consumption with no decrease in production.

**A powerful Komatsu SAA6D107E-2 engine** provides a net output of 123 kW **165 HP** with up to 10% improved fuel consumption. This engine is EPA Tier 4 Interim and EU stage 3B emissions certified.

**Komatsu Variable Geometry Turbocharger (KVG T)** uses a hydraulic actuator to provide optimum air flow under all speed and load conditions.

**Komatsu Diesel Particulate Filter (KDPF)** captures 90% of particulate matter and provides automatic regeneration that does not interfere with daily operation.

### Increased cooling capacity

- Auto-reversing fan is standard
- Wider core coolers

**An all new cab** provides the operator with improved comfort and visibility.

### New high resolution monitor panel

- Enhanced and intuitive on-board diagnostics
- Integrated with KOMTRAX Level 4
- Integrated with Komatsu Tier 4 technology

### Rearview monitoring system (standard)

### New high capacity air suspension seat

- Seat mounted EPC controls with F-N-R switch
- Seat heater is standard

### Energy saving guidance

- Six operator guiding messages
- Enhanced eco-gauge

**Komatsu Auto Idle Shutdown** helps reduce idle time and reduce operating costs.



**Remote boom positioner** can set kickout.

**Variable displacement piston pumps with CLSS** help reduce fuel consumption.

## KOMTRAX®

Komtrax equipped machines can send location, SMR and operation maps to a secure website utilizing wireless technology. Machines also relay error codes, cautions, maintenance items, fuel levels, and much more.

# HIGH PRODUCTIVITY & LOW FUEL CONSUMPTION

WA320-7

## High Performance Komatsu SAA6D107E-2 Engine

The Komatsu SAA6D107E-2 engine is EPA Tier 4 Interim and EU Stage 3B emissions certified and provides exceptional performance while reducing fuel consumption. Based on Komatsu proprietary technologies developed over many years, this new diesel engine reduces exhaust gas particulate matter (PM) by more than 90% and nitrogen oxides (NOx) by more than 45% when compared to Tier 3 levels.

Through the in-house development and production of engines, electronics, and hydraulic components, Komatsu has achieved great advancements in technology, providing high levels of performance and efficiency in virtually all applications. The operator will notice high torque at low speeds, excellent operation and low fuel consumption to provide maximum productivity.



## Komatsu Diesel Particulate Filter (KDPF)

Komatsu has developed a high efficiency diesel particulate filter that captures more than 90% of particulate matter. Both passive and active regeneration are automatically initiated by the engine controller depending on the soot level of the KDPF. A special oxidation catalyst with a fuel injection system is used to oxidize and remove particulate matter while the machine is running so the regeneration process will not interfere with daily operation.

The operator can also initiate regeneration manually or disable regeneration depending on the work environment.

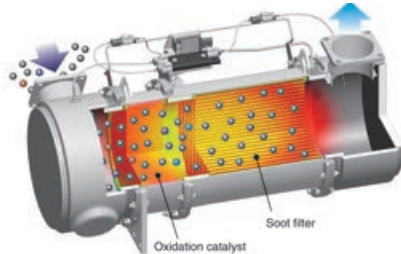

## Closed Crankcase Ventilation (CCV)

Crankcase emissions (blow-by gas) are passed through a CCV filter. The CCV filter traps oil mist which is returned back to the crankcase while the gas, which is almost oil mist free, is fed back to the air intake.



## Heavy Duty High Pressure Common Rail (HPCR) Fuel Injection System

The heavy duty HPCR system is electronically controlled to deliver a precise quantity of pressurized fuel into the combustion chamber using multiple injection events to achieve complete fuel burn and reduce exhaust gas emissions. Fuel injector reliability has been improved by using ultra-hard wear resistant materials.

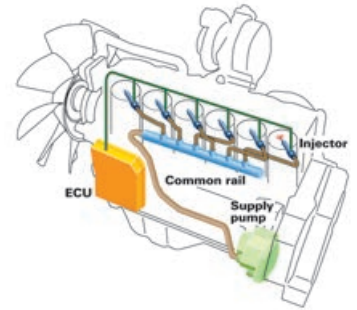

## Komatsu Variable Geometry Turbocharger (KVTG)

Using Komatsu proprietary technology, a newly designed variable geometry turbocharger with a hydraulic actuator is used to manage and deliver optimum air flow to the combustion chamber under all speed and load conditions. The robust hydraulic actuator provides power and precision, resulting in cleaner exhaust gas, quick acceleration and improved fuel economy while maintaining performance.

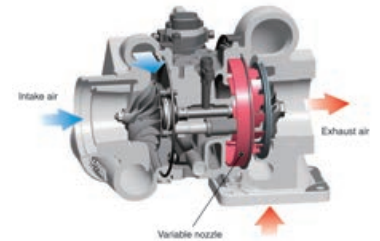

## Redesigned Combustion Chamber

The combustion chamber located at the top of the engine piston has a new shape designed to improve combustion and further reduce NOx, PM, fuel consumption, and noise levels.

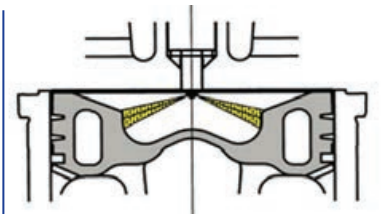

## Cooled Exhaust Gas Recirculation (EGR)

Cooled EGR, a technology that has been well proven in Komatsu Tier 3 engines, reduces NOx emissions to meet Tier 4 levels. The hydraulically actuated EGR system has increased capacity and uses larger and more robust components to ensure reliability for demanding work conditions.

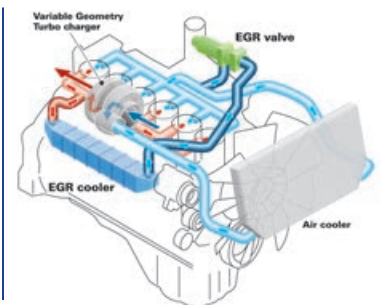

## Komatsu SmartLoader Logic

Wheel loaders have different torque requirements depending on working conditions. Komatsu SmartLoader Logic reads data from various sensors and vehicle controls to precisely control the torque output. This lowers the torque output during less demanding work, saving fuel. And because its seamless to the operator, it operates without decreasing production.

## Closed Center Load Sensing System

The 1-pump, 2-motor system utilizes a Closed Center Load Sensing pump (CLSS). This system minimizes hydraulic loss for better fuel economy by delivering just as much flow as the job requires. This means there is no wasted flow.

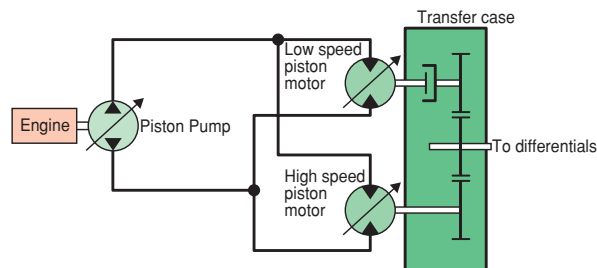

## Variable Traction Control System

The new variable speed control system is designed to adjust the operating speed for each working condition. S-mode reduces tire spin in slippery or snowy conditions. Auto-mode automatically optimizes the tractive effort for various working conditions. Max traction provides the full, 100%, tractive effort.

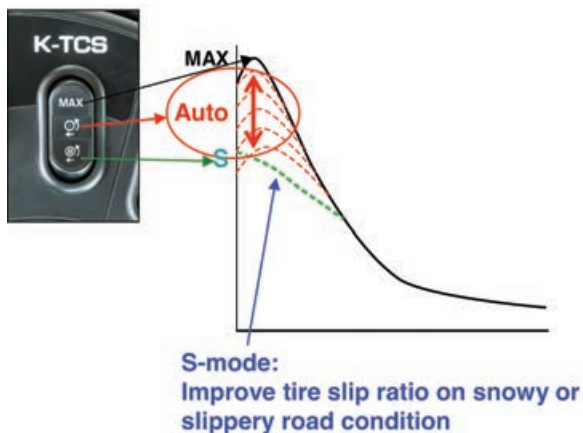

## Fuel consumption decreased by up to 10%

(Compared with the WA320-6)

## Hydrostatic Transmission

The HST provides quick travel response and aggressive drive into the pile. Full auto-shifting eliminates any gear shifting and kick-down operation to allow the operator to concentrate on the digging and loading. The HST also acts as a dynamic brake to slow the loader. This prolongs the life of the wet disc brakes.

## Eco-Guidance

In order to support optimum operation, the following 4 recommendations are displayed to improve fuel saving operation:



- 1) Avoid Excessive Engine Idling
- 2) Use Economy Mode to Save Fuel
- 3) Avoid Hydraulic Relief Pressure
- 4) Traction Control Recommendation

The operator can access the Eco guidance menu to check the Operation Records, Eco Guidance Records, and Average Fuel Consumption logs.

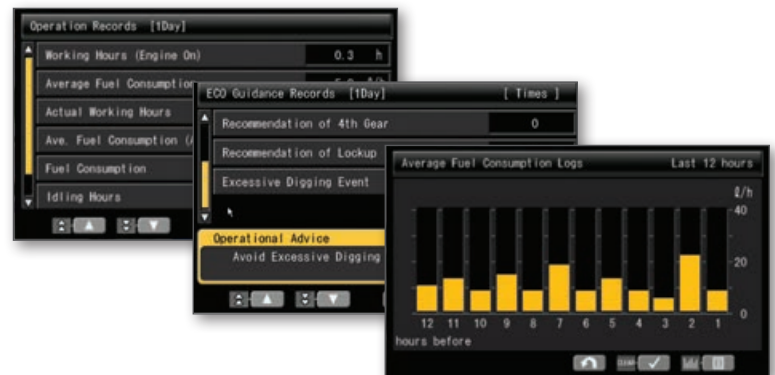

## Creep Mode

Creep mode limits the travel speed while still allowing for full hydraulic flow.



### New Designed Cabin

The new cabin offers better ergonomics, more storage space and more features to improve operator comfort.



WA320-7

#### Heated Operator Seat with Air Suspension

A new higher capacity heated, air suspension seat with suspension damper is now standard. The arm rest angle is fully adjustable for optimum operator comfort.



#### Tiltable / Telescopic Steering Wheel

The WA320-7 comes standard with a tiltable and telescopic steering wheel that can be moved forward and out of the way for easy entry and exit of the cab.



#### Low Noise Design

Operator's ear noise level : 70 dB(A)

Dynamic noise level (outside): 107 dB(A)

The large cab is mounted with Komatsu's unique ROPS/FOPS viscous mounts. The low-noise engine, hydraulically driven fan, and hydraulic pumps are mounted with rubber cushions, and the cab sealing is designed to provide a quiet, low-vibration, dustproof, and comfortable operating environment.



#### Increased Cab Storage Area

The WA320-7 cab features a storage box on the left hand side of the cab to allow the operator to store items out of the way. A storage box on the right hand side of the cab allows the operator to keep a beverage or lunch out of the way.



## Ergonomic Comfort

The dashboard and cab have been redesigned to improve operator comfort. The monitor can be controlled by the multi-switch panel. Also, the front glass of the cab has been lowered to improve visibility.



### Rear View Monitoring System (standard)

The operator can view the area directly behind the machine with a full color monitor that is located on the right side of the cab. This monitor can be always on or only on when the loader goes into reverse. Visual guidelines can also be added to show the machine's travel path.



### Seat Belt Caution Indicator

A warning indicator on the monitor appears when the seat belt is not engaged.



### Engine Shutdown Secondary Switch

The engine stop switch is incorporated to allow shutdown of the machine when accessing the key switch is not possible.



### Auxiliary Input (MP3 Jack) 12 V Outlets

An Aux input to allow use of an MP3 player or other device is now standard as well as two 12 volt outlets. These are all easily accessible to the left rear of the operator's seat.

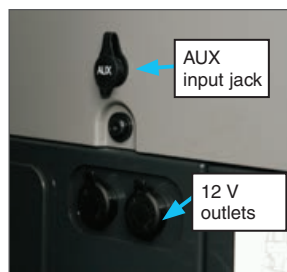



### Easy Entry and Egress

The WA320-7 has an inclined ladder with wide steps and well placed hand holds to ease entry and exit from the cab. The door latch can be reached from ground level to ease opening and closing the door.

### Electronically Controlled Suspension System (ECSS)

The Electronically Controlled Suspension System (ECSS) or ride control system uses an accumulator which absorbs some of the shock in the boom arm, giving the operator a much smoother ride. This reduces operator fatigue and reduces material spillage during load and carry operations. ECSS is speed sensitive, meaning that the boom won't move during stationary digging. ECSS is standard on the WA320-7.

### Multi-Function Mono Lever

The multi-function mono lever with EPC control for 3rd spool is standard. It includes a forward-neutral-reverse switch for quick and easy travel. Third spool attachments can be set to continual or proportional control via the monitor panel allowing the operator to control the boom, bucket and attachment all with a single lever.



### Remote Boom Positioner

The operator can set the upper boom kickout from the cab.

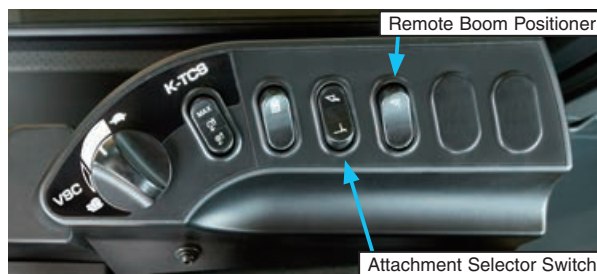

### Attachment Selector Switch

Coupler equipped machines which use buckets and forks require a different flat level setting when switching between attachments. The attachment selector switch found in coupler equipped machines tells the loader which flat level to use.



## INFORMATION & COMMUNICATION TECHNOLOGY

### New High Resolution LCD Monitor Panel

The new 7" color LCD monitor panel displays operational information, Eco-Guidance and maintenance records. Information such as traction mode, coolant temp, oil and fuel levels are easy to read to keep the operator informed of the machine's settings and conditions.

#### Machine monitor

- 1 LCD unit
- 2 LED unit
- 3 Engine tachometer
- 4 Speedometer
- 5 ECO gauge
- 6 Air conditioner display
- 7 Traction level
- 8 Engine coolant temperature gauge
- 9 Fuel gauge
- 10 HST oil temperature gauge
- 11 Variable speed display
- 12 Message pilot lamp
- 13 Pilot lamps

#### Switch panel

- 1 Air conditioner switches / Numeral key pad
- 2 Function switches

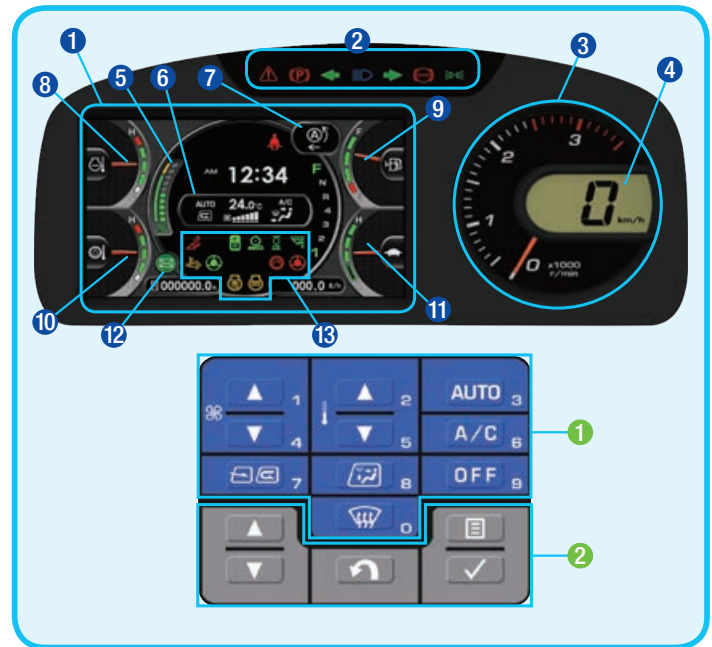

### Easy To Use Tab System

The easy to use tab system is controlled through the switch panel. Reading like pages, the tabs hold and display operational records, fuel consumption, KDPF regeneration information and much more. Finding the right information is quick and easy.



### Maintenance and Service Mode

Maintenance menu and service mode mean that a technician doesn't need to plug a laptop into the machine. Customizable service screens help speed diagnostics.



### Know One, Know Them All

Commonality between product lines means that if an operator is familiar with one machine, they will be familiar with others as well. This makes it easier on operators switching between machines on a job site.

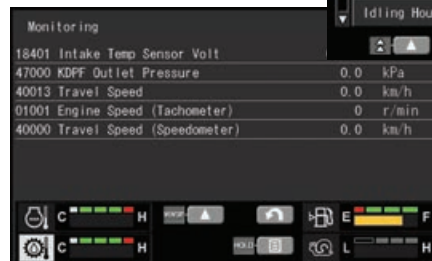



Photos may include optional equipment

### Full Side-Opening Gull-Wing Engine Doors

The large gull-wing type engine doors are operated with low effort assisted by gas springs. The doors open in two steps for easy access to maintenance points. Large steps and hand holds are provided on each side of the frame to help access.



Photos may include optional equipment

### Swing-out Type Cooling Unit

The large capacity cooling unit swings open for cleaning. It features wider spacing of cooling fins to reduce clogging.



Photos may include optional equipment

### Auto Reversing Fan

The engine cooling fan is driven hydraulically. It can be set to reverse automatically during operation. Fan reverse mode and timing can be controlled through the monitor.



### Maintenance Function

The monitor informs the operator when the replacement interval for oil and filters will be reached.



### Battery Disconnect

The battery disconnect switch is located in front of the right side battery box. This can be used to disconnect power when performing service work on the machine.



## Engine Compartment

The WA320-7 engine compartment was laid out for easy serviceability. Great attention was paid to the location of the maintenance items, such as the filters, dipstick and oil fill locations. The same goes for the KDPF and CCV filter, as even the top of the hood was redesigned to ease removal of the KDPF for cleaning or replacement.



## KDPF Regeneration

The LCD color monitor panel provides the operator with the status of the KDPF regeneration, without interfering with daily operation.

When the machine automatically initiates active regeneration, an icon will appear to notify the operator.

KDPF regeneration indicator



## Manual Stationary Regeneration

Under most conditions, active regeneration will occur automatically with no effect on machine operation. In case the operator needs to disable active regeneration or initiate a manual stationary regeneration, this can be easily accomplished through the monitor panel.

A soot level indicator is displayed to show how much soot is trapped in the KDPF.

Soot level indicator



## Rear Full Fenders (Option)

The WA320-7 has a new rear fender option. The rear fenders open upward and use gas assist struts which require low lift force.

The fenders swing up with the gull wing doors to give the technician easy access to the engine compartment. Mud flaps are also included on the rear fenders.



## Cab Air Intake Filter

The cab air intake filter is located beneath the door, on the left hand side of the machine behind a lockable door, for easy access and security.





## Komatsu CARE – Complimentary Scheduled Maintenance

- PM services for the earlier of 3 years / 2000 hours
- Performed by factory certified technicians
- Komatsu Genuine parts and fluids
- Significantly lowers your cost of ownership while maintaining high uptime and reliability
- Increases resale value and provides detailed maintenance records
- Extended PM services can be purchased beyond the complimentary period to provide additional peace of mind and maximize uptime



## Komatsu CARE – Extended Coverage

- Extended Coverage can provide peace of mind by protecting customers from unplanned expenses that effect cash flow
- Purchasing extended coverage locks-in the cost of covered parts and labor for the coverage period and helps turn these into fixed costs



## Komatsu Parts Support

- 24/7/365 to fulfill your parts needs
- 9 parts Distribution Centers strategically located across the U.S. and Canada
- Distributor network of more than 300 locations across U.S. and Canada to serve you
- Online part ordering through Komatsu eParts
- Remanufactured components with same-as-new warranties at a significant cost reduction



## Komatsu Oil and Wear Analysis (KOWA)

- KOWA detects fuel dilution, coolant leaks, and measures wear metals
- Proactively maintain your equipment
- Maximize availability and performance
- Can identify potential problems before they lead to major repairs
- Reduce life cycle cost by extending component life

## KOMTRAX EQUIPMENT MONITORING

GET THE WHOLE STORY WITH  
**KOMTRAX**®

### ✓ WHAT

- KOMTRAX is Komatsu's remote equipment monitoring and management system
- KOMTRAX **continuously monitors and records** machine health and operational data
- Information such as fuel consumption, utilization, and a detailed history **aids in making repair or replacement decisions**

### ✓ WHEN

- Know when your machines are **running or idling** and make decisions that will improve your fleet utilization
- Detailed movement records ensure you know when and where your equipment is moved
- Up to date records allow you to **know when maintenance was done** and help you plan for future maintenance needs

### ✓ WHERE

- KOMTRAX data **can be accessed virtually anywhere** through your computer, the web or your smart phone
- Automatic alerts keep fleet managers up to date on the latest machine notifications

### ✓ WHY

- Knowledge is power - **make informed decisions** to manage your fleet better
- Knowing your idle time and fuel consumption will help maximize your machine efficiency
- **Take control of your equipment** - any time, anywhere

### ✓ WHO

- KOMTRAX is **standard** equipment on all Komatsu construction products



#### Monthly Operational Analysis



#### Fleet Working Status

Machine No.	Model	Serial No.	Hours	Days of Operation	Days of Maintenance	Days of Idle
WA320-7	WA320-7	12345	1000	10	2	8
WA320-7	WA320-7	6789	1500	15	3	12
WA320-7	WA320-7	2345	800	8	1	7
WA320-7	WA320-7	5678	1200	12	2	10
WA320-7	WA320-7	9012	900	9	1	8
WA320-7	WA320-7	3456	1100	11	2	9
WA320-7	WA320-7	7890	1300	13	3	10
WA320-7	WA320-7	1122	1400	14	2	12
WA320-7	WA320-7	3333	1600	16	3	13
WA320-7	WA320-7	4444	1700	17	4	13
WA320-7	WA320-7	5555	1800	18	4	14
WA320-7	WA320-7	6666	1900	19	5	14
WA320-7	WA320-7	7777	2000	20	5	15
WA320-7	WA320-7	8888	2100	21	6	15
WA320-7	WA320-7	9999	2200	22	6	16
WA320-7	WA320-7	0000	2300	23	7	16
WA320-7	WA320-7	1111	2400	24	7	17
WA320-7	WA320-7	2222	2500	25	8	17
WA320-7	WA320-7	3333	2600	26	8	18
WA320-7	WA320-7	4444	2700	27	9	18
WA320-7	WA320-7	5555	2800	28	9	19
WA320-7	WA320-7	6666	2900	29	10	19
WA320-7	WA320-7	7777	3000	30	10	20

#### Location/Hours/Working



**KOMTRAX**®

For construction and compact equipment.

**KOMTRAX Plus**™

For production and mining class machines.

# SPECIFICATIONS

WA320-7



## ENGINE

Model..... Komatsu SAA6D107E-2\*  
 Type ..... Water-cooled, 4-cycle  
 Aspiration..... Turbo-charged, after-cooled, cooled EGR  
 Number of cylinders..... 6  
 Bore ..... 107 mm **4.21"**  
 Stroke ..... 124 mm **4.88"**  
 Piston displacement..... 6.69 ltr **408 in³**  
 Governor ..... All-speed, electronic  
 Horsepower:  
   SAE J1995..... Gross 127 kW **170 HP**  
   ISO 9249 / SAE J1349 ..... Net 123 kW **165 HP**  
   Rated rpm ..... 2100 rpm  
   Max power - ISO 14396 ..... 126 kW **169 HP** @ 1900 rpm  
 Fan drive method for radiator cooling ..... Hydraulic  
 Fuel system ..... Direct injection  
 Lubrication system:  
   Method ..... Gear pump, force-lubrication  
   Filter ..... Full-flow type  
 Air cleaner ..... Dry type with double elements and dust evacuator, plus dust indicator

\*EPA Tier 4 Interim and EU stage 3B emissions certified



## TRANSMISSION

Transmission..... Hydrostatic, 1 pump, 2 motors with speed range select

Travel speed	Forward	Reverse
<b>1st</b>	1.0 - 13.0 km/h <b>0.6 - 8.1 mph</b>	1.0 - 13.0 km/h <b>0.6 - 8.1 mph</b>
<b>2nd</b>	13.0 km/h <b>8.1 mph</b>	13.0 km/h <b>8.1 mph</b>
<b>3rd</b>	18.7 km/h <b>11.6 mph</b>	18.7 km/h <b>11.6 mph</b>
<b>4th</b>	38.0 km/h <b>23.6 mph</b>	38.0 km/h <b>23.6 mph</b>

Measured with 20.5-R25 tires



## AXLES AND FINAL DRIVES

Drive system ..... Four-wheel drive  
 Front ..... Fixed, semi-floating  
 Rear ..... Center-pin support, semi-floating, 24° total oscillation  
 Reduction gear ..... Spiral bevel gear  
 Differential gear ..... Torque proportioning  
 Final reduction gear ..... Planetary gear, single reduction



## BRAKES

Service brakes ..... Hydraulically actuated, wet disc brakes actuate on four wheels  
 Parking brake..... Wet, multi-disc brake on transfer output shaft  
 Secondary brake ..... Parking brake is commonly used



## STEERING SYSTEM

Type ..... Articulated type, fully-hydraulic power steering  
 Steering angle..... 38.5° each direction (40° to max end stop)  
 Minimum turning radius at the center of outside tire ..... 5380 mm **17' 8"**



## HYDRAULIC SYSTEM

Steering system:  
 Hydraulic pump ..... Piston pump, in common with loader control  
 Capacity ..... 180 ltr/min **47.6 U.S. gal/min** at rated rpm  
 Relief valve setting ..... 20.6 MPa 210 kgf/cm² **3,000 psi**  
 Hydraulic cylinders:  
   Type ..... Double-acting, piston type  
   Number of cylinders ..... 2  
   Bore x stroke ..... 70 mm x 453 mm **2.76" x 17.8"**

Loader control:  
 Hydraulic pump ..... Piston pump, in common with steering system  
 Capacity ..... 180 ltr/min **47.6 U.S. gal/min** at rated rpm  
 Relief valve setting ..... 30.4 MPa 310 kgf/cm² **4,410 psi**  
 Hydraulic cylinders:  
   Type ..... Double-acting, piston type  
   Number of cylinders—bore x stroke:  
     Lift cylinder ..... 2- 120 mm x 729 mm **4.7" x 28.7"**  
     Bucket cylinder ..... 1- 150 mm x 558 mm **5.9" x 22"**  
 Control valve ..... 2-spool type  
 Control positions:  
   Boom ..... Raise, hold, lower, and float  
   Bucket ..... Tilt-back, hold, and dump  
 Hydraulic cycle time (rated load in bucket)  
   Raise ..... 6.1 sec  
   Dump ..... 1.9 sec  
   Lower (Empty) ..... 3.5 sec



## SERVICE REFILL CAPACITIES

Cooling system ..... 28 ltr **7.4 U.S. gal**  
 Fuel tank ..... 245 ltr **64.7 U.S. gal**  
 Engine ..... 23 ltr **6.1 U.S. gal**  
 Hydraulic system..... 90 ltr **23.7 U.S. gal**  
 Axle front ..... 27 ltr **7.1 U.S. gal**  
 Axle rear..... 25.5 ltr **6.7 U.S. gal**  
 Transfer case ..... 5.8 ltr **1.5 U.S. gal**



## BUCKET SELECTION GUIDE

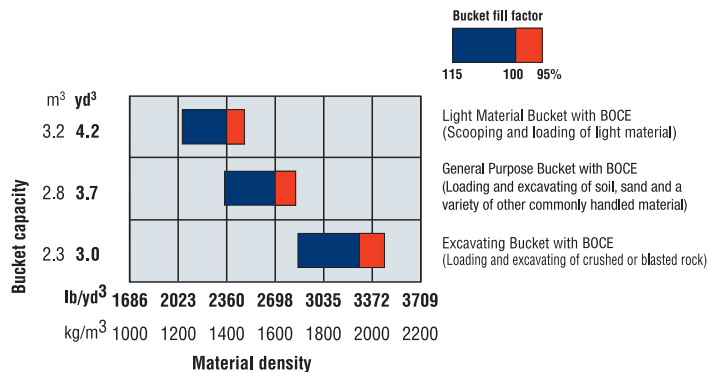



## DIMENSIONS

Measured with 20.5-R25(L3) tires, ROPS/FOPS cab

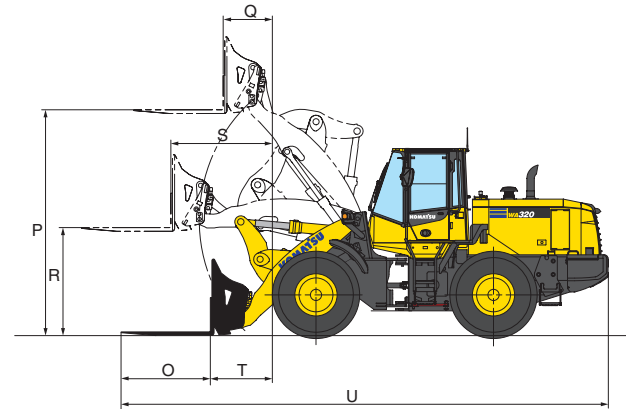
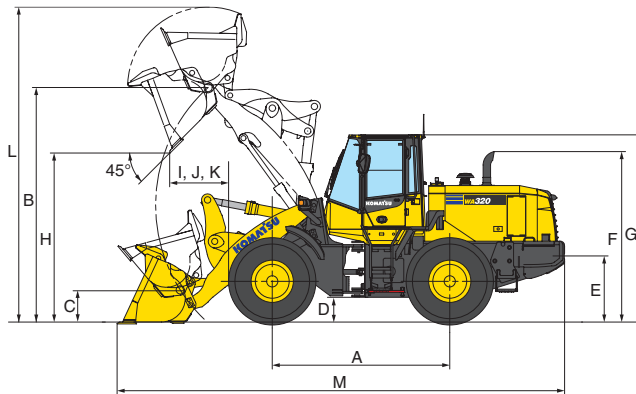

Tread	2050 mm	<b>6'9"</b>
Width over tires	2590 mm	<b>8'6"</b>
A Wheelbase	3030 mm	<b>9'11"</b>
B Hinge pin height, maximum	4005 mm	<b>13'2"</b>
C Hinge pin height, carry position	553 mm	<b>1'10"</b>

D Ground clearance	425 mm	<b>1'5"</b>
E Hitch height	1085 mm	<b>3'7"</b>
F Overall height, top of the stack	2910 mm	<b>9'7"</b>
G Overall height, ROPS cab	3200 mm	<b>10'6"</b>

## BUCKET

	General Purpose Bucket w/ Pin On	Light Material Bucket w/ Pin On	General Purpose Bucket w/ Quick Coupler
	Bolt-on Cutting Edge	Bolt-on Cutting Edge	Bolt-on Cutting Edge
Bucket capacity: heaped	2.8 m <sup>3</sup> <b>3.7 yd<sup>3</sup></b>	3.2 m <sup>3</sup> <b>4.2 yd<sup>3</sup></b>	2.7 m <sup>3</sup> <b>3.5 yd<sup>3</sup></b>
struck	2.4 m <sup>3</sup> <b>3.1 yd<sup>3</sup></b>	2.8 m <sup>3</sup> <b>3.7 yd<sup>3</sup></b>	2.2 m <sup>3</sup> <b>2.9 yd<sup>3</sup></b>
Bucket width	2740 mm <b>9'0"</b>	2740 mm <b>9'0"</b>	2740 mm <b>9'0"</b>
Bucket weight	1330 kg <b>2,932 lb</b>	1445 kg <b>3,186 lb</b>	1260 kg <b>2,778 lb</b>
H Dumping clearance, max. height and 45° dump angle*	2880 mm <b>9'5"</b>	2745 mm <b>9'0"</b>	2785 mm <b>9'2"</b>
I Reach at max. height and 45° dump angle*	1000 mm <b>3'3"</b>	1110 mm <b>3'8"</b>	1260 mm <b>4'2"</b>
J Reach at 2130 mm 7° clearance and 45° dump angle*	1595 mm <b>5'3"</b>	1620 mm <b>5'4"</b>	1770 mm <b>5'10"</b>
K Reach with arm horizontal and bucket level*	2500 mm <b>8'2"</b>	2665 mm <b>8'9"</b>	2735 mm <b>9'0"</b>
L Operating height (fully raised)	5375 mm <b>17'8"</b>	5465 mm <b>17'11"</b>	5425 mm <b>17'10"</b>
M Overall length (bucket on ground)	7635 mm <b>25'0"</b>	7800 mm <b>25'7"</b>	7675 mm <b>25'2"</b>
Loader clearance circle (bucket at carry, outside corner of bucket)	12620 mm <b>41'5"</b>	12715 mm <b>41'9"</b>	12660 mm <b>41'6"</b>
Digging depth: 0°	165 mm <b>6.5"</b>	165 mm <b>6.5"</b>	65 mm <b>3"</b>
10°	375 mm <b>1'3"</b>	410 mm <b>1'4"</b>	329 mm <b>1'9"</b>
Static tipping load: straight	11630 kg <b>25,640 lb</b>	11740 kg <b>25,882 lb</b>	11518 kg <b>25,393 lb</b>
40° full turn	9610 kg <b>21,186 lb</b>	9730 kg <b>21,451 lb</b>	9823 kg <b>21,656 lb</b>
Breakout force	162 kN 16470 kgf <b>36,310 lb</b>	139 kN 14130 kgf <b>31,151 lb</b>	140 kN 14240 kgf <b>31,394 lb</b>
Operating weight	15300 kg <b>33,731 lb</b>	15415 kg <b>33,984 lb</b>	15670 kg <b>34,546 lb</b>

\* At the end of tooth or B.O.C.E.

All dimensions, weights, and performance values based on SAE J732c and J742b standards. Static tipping load and operating weight shown include lubricant, coolant, full fuel tank, ROPS cab and operator. Machine stability and operating weight affected by tire size and attachments.

## FORK

	Fork With Quick Coupler
O Fork tine length	1524 mm <b>5'0"</b>
P Ground to top of tine at maximum lift	3855 mm <b>12'7"</b>
Q Reach at maximum lift	840 mm <b>2'9"</b>
R Ground to top of tine - boom and tine level	1845 mm <b>6'0"</b>
S Reach - boom and tine level	1730 mm <b>5'8"</b>
T Reach - tine level on ground	1060 mm <b>3'6"</b>
U Overall length - tine level on ground	8320 mm <b>27'3"</b>
Static tipping load - boom level:	straight
fork level, tine center	8310 kg <b>18,320 lb</b>
	40° full turn
	7120 kg <b>15,697 lb</b>
Operating weight	15080 kg <b>33,246 lb</b>

Operating load per SAE J1197 (Feb. 1991), 50% of static tipping load. Static tipping load and operating weight shown include lubricant, coolant, full fuel tank, ROPS cab and operator. Machine stability and operating weight affected by tire size and attachments.



## WEIGHT CHANGES

Tires or attachments	Change in operating weight		Change in tipping load				Width over tires		Ground clearance		Change in vertical dimensions	
			Straight		Full turn							
	kg	lb	kg	lb	kg	lb	mm	ft in	mm	ft in	mm	ft in
20.5-25-12PR (L2)	-165	-364	-105	-231	-95	-209	2585	8'6"	425	1'5"	0	0
Remove additional counterweight	-250	-551	-440	-970	-363	-800	0	0	0	0	0	0



## STANDARD EQUIPMENT

- 2-spool valve for boom and bucket control
- Alternator, 60 A
- Automatic hydraulic-driven fan with automatic reverse rotation
- Back-up alarm
- Batteries, 92 Ah/12V (2), 680 CCA
- Battery disconnect
- Boom kick-out, in-cab adjustable
- Bucket positioner
- Color rear view camera and monitor
- Counterweight, standard and additional
- Electronically Controlled Suspension System (ECSS)
- Engine, Komatsu SAA6D107E-2 diesel
- Engine shut-off system, electric
- Equipment Management Monitoring System (EMMS)
  - Lights (central warning, brake oil pressure, engine oil pressure, parking brake, cooling fan reverse, KDPF restriction, seat belt caution, Komtrax message)
  - Gauges (Engine water temperature, ECO, Fuel level, HST oil temperature, speedometer/tachometer), variable speed display
- Front fenders
- Fuel pre-filter with water separator
- Horn, electric
- Hydrostatic transmission
- Komatsu SmartLoader Logic
- Komatsu Auto Idle Shutdown
- KOMTRAX® Level 4
- Lift cylinders and bucket cylinder
- Lights
  - Back-up light
  - Stop and tail light
  - Turn signal lamps, 2 front and 2 rear with hazard switch
  - Working lights, halogen, 2 front cab mount
  - Working lights, halogen, 2 front fender mount
  - Working lights, halogen, 2 rear grill mount
- Loader linkage with standard lift arm
- Multifunction mono-lever loader control with transmission F/R switch
- Parking brake, electric
- Radiator, wider core
- Radiator mask, swing up
- Rear view mirrors, outside (2) inside (2)
- Rims for 20.5-R25 tires
- ROPS/FOPS Cab Level 2
  - 2 x DC12V electrical outlets
  - Ashtray
  - Auto air conditioner
  - Cigarette lighter, 24V
  - Color LCD/TFT multi-monitor
  - Cup holder
  - Floor mat
  - Operator seat, reclining, air suspension type, heated
  - Radio, AM/FM with AUX input jack
  - Rear defroster, electric
  - Seatbelt, 2-point retractable, 76mm **3"** width
  - Space for lunch box
  - Steering wheel, tilt and telescopic
  - Sun visor, front window
  - Windshield washer and wiper, front with intermittent
  - Windshield washer and wiper, rear
- Service brakes, wet disc type
- Starting motor, 5.5 kW
- Transmission speed ranges, 4 forward and 4 reverse
- Vandalism protection kit, padlocks for battery box (2)



## OPTIONAL EQUIPMENT

- 3-spool valve (will utilize integrated proportional control switch included in the multi-function mono-lever) and piping
- Auxiliary steering (SAE)
- Cutting edge (bolt-on type)
- Limited slip differential (F&R)
- Quick coupler
- Rear full fenders
- Various tire options, radial and bias
- Various bucket options

# KOMATSU®