

SERIES 1800 SCREENING/WASHING PLANT

Model 1822PHB Spec Sheet

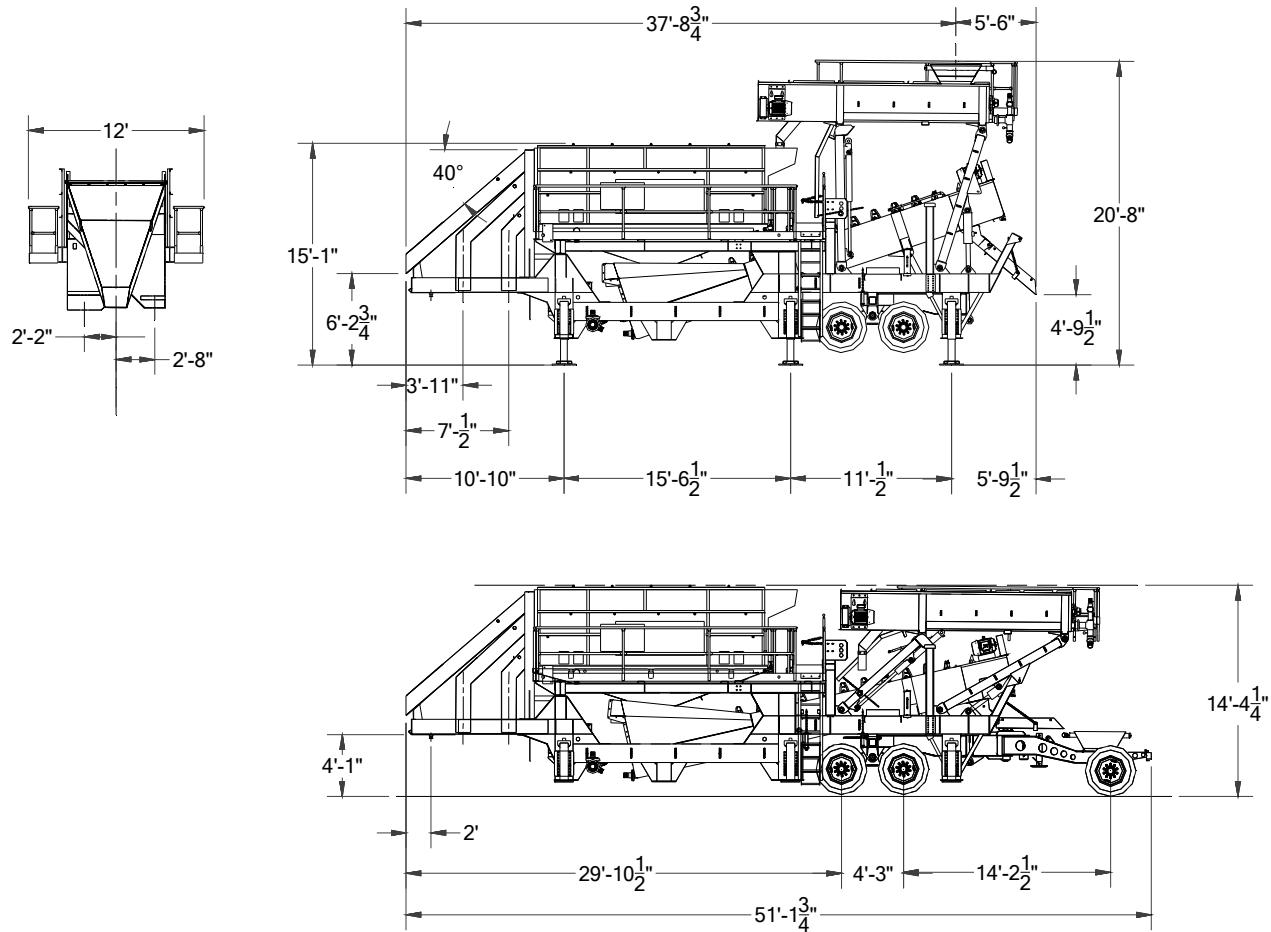

● SCREEN

- KPI-JCI 6' x 16', 3-deck horizontal wet vibrating screen
 - V-belt drive assembly with 40-HP, 1200 RPM motor
 - Huck-bolted assembly
 - 1/4" plate steel side plates
 - 160-mm double-roll spherical self-aligned bearings
 - Triple shaft vibrating mechanism complete with keyless hold-fast hub locking assembly
 - Oval motion stroke pattern
 - Adjustable stoke amplitude (3/8" - 5/8")
 - Adjustable stoke angle (30° - 60° in 5° increments)
 - Adjustable speed via adjustable motor sheave (675 - 875 RPM)
 - Fully contained oil splash lubrication system
 - Bolt-on tailgates, 24" feedbox and 4" discharge lips
 - Steel coil springs
 - Side tension drawbar screen cloth retention system (screen cloth is optional)

● FINE MATERIAL WASHER

- KPI-JCI Model 5036-25T (36" twin) fine material washer
 - Tank is of 3/16" (sides and bottom) and 3/8" (rear end plate) welded plate steel construction and includes a curved bottom with integral rising current manifold (4" dia. inlet)
 - Large undisturbed pool area with adjustable weir boards and overflow flume with 10" dia outlet
 - Double pitch, solid flight spiral assembly with standard AR steel inner wear shoes and standard urethane outer wear shoes
 - Greaseable, externally mounted Dodge Imperial E tail end flange bearing; greaseable Dodge pillow block head end bearing
 - Lower end seal - chrome plated stainless steel wear sleeve, water tight bellows type rubber seal and secondary grease seal
 - High efficiency v-belt drive assembly (one drive assembly per spiral) includes 15-HP TEFC motor and Dodge TA-II double reduction shaft mount reducer
 - Tapered discharge chute set at 45° angle to grade
- See Model 5036-25T Spec Sheet for additional information

● BLADEMILL

- KPI-JCI Model 6524-12T (24" twin) blademill
- Tank is of 3/16" (sides and bottom) and 3/8" (rear end plate) welded plate steel construction and includes integral rising current manifold (4" dia inlet)
- Double pitch, combination of bolt-on flight and paddle assemblies with cast ni-hard outer wear shoes and cast ni-hard paddle tips
- Greaseable, externally mounted Dodge Imperial E tail end flange bearing; greaseable Dodge pillow block head end bearing
- Lower end seal - chrome plated stainless steel wear sleeve, water tight bellows type rubber seal and secondary grease seal
- High efficiency v-belt drive assembly (one drive assembly per spiral) includes 15-HP TEFC motor and Dodge TA-II double reduction shaft mount reducer
- Tapered discharge chute with 3/16" AR liners and flashing to discharge onto the screen
- Feed box with header pipe

● CHASSIS

- Heavy duty 15" and 12" I-beam construction
- 2+1 axle arrangement with Dana 22,000# axles and twelve (12) 11:00 x 22.5 tires
- Fifth wheel king pin, air brakes, travel lights, mudflaps and cribbing locations
- Fixed supports for the screen
- Hydraulically adjusted supports for the fine material washer and the blademill

● WATER SYSTEM

- All fresh water plumbing to a single 8" inlet located near the tail end of the fine material washer
- Fine material washer manifold includes a 4" butterfly valve, 4" swing check valve and pressure gauge
- 2" chase water plumbing with gate valves
- Screen manifold with flow control valves for each spray bar
- Fourteen (14) spray bars each with nineteen (19) 10.0 gpm (@40 psi) spray nozzles
- Blademill plumbing includes a 4" butterfly flow control valve and 3" gate valve with plumbing to the feed box

● SCREEN CHUTES / FINES HOPPER

- 3/16" A36 welded plate steel construction
- Chutes allow for positioning of three (3) radial stackers under the chutes
- Fines hopper transitions to form the feed box and baffle plate of the 36" twin fine material washer

FOR MORE INFORMATION CALL 1-800-542-9311 AND ASK FOR A KOLBERG EQUIPMENT SPECIALIST

NOTE: Specifications are subject to change without notice.

Because KPI-JCI may use in its catalog & literature, field photographs of its products which may have been modified by the owners, products furnished by KPI-JCI may not necessarily be as illustrated therein. Also continuous design progress makes it necessary that specifications be subject to change without notice. All sales of the products of KPI-JCI are subject to the provisions of its standard warranty. KPI-JCI does not warrant or represent that its products meet any federal, state, or local statutes, codes, ordinances, rules, standards or other regulations, including OSHA and MSHA, covering safety, pollution, electrical wiring, etc. Compliance with these statutes and regulations is the responsibility of the user and will be dependent upon the area and the use to which the product is put by the user. In some photographs, guards may have been removed for illustrative purposes only. This equipment should not be operated without all guards attached in their normal position. Placement of guards and other safety equipment is often dependent upon the area and how the product is used. A safety study should be made by the user of the application, and, if required additional guards, warning signs and other safety devices should be installed by the user, wherever appropriate before operating the products.

● ACCESS

- 28-1/2" wide access platform with 1-1/2" OD handrails and toeboards across the feed end of the screen
- 19" wide access platform with 1-1/2" OD handrails and toeboards along both sides of the screen
- Ladder access from grade which can be located on either side of the plant

● PHYSICAL / OPERATING CHARACTERISTICS

- Feed Material Size - Typically 2-1/2" minus
- Capacity - Approximately 400 TPH (dependent on feed gradation and desired products)
- Water Requirements - Up to 1,200 gpm (dependent on feed gradation and desired products)
- Travel Dimensions
 - Length 51'-2" overall / 46'-4" king pin to rear axle
 - Width 12'-0"
 - Height 14'4"
- Operating Dimensions
 - Length 43'-3" overall
 - Width 12'-9"
 - Height 20'-8"
- Loads
 - King Pin 32,800 lbs
 - Axle 59, 200 lbs
 - Overall 92,000 lbs

Note individual plant weights will vary dependent on options included

● OPTIONAL EQUIPMENT

- AR or urethane chute and hopper wear liners
- Wire mesh or urethane screen media
- Electrical package
- Blending gates
- Landing Gear
- Hydraulic run-on jacks with electrical or gas power pack
- Swing-away top and middle deck overs chutes
- Cross conveyors
- Remote grease package
- Blademill walkway with access ladder



700 W 21st. St., Yankton, SD 57078
1-800-542-9311 Fax: 605-665-8858

Email: mail@kpijci.com
www.kpijci.com
Mdl 1822PHB Rev. 1, 08/09