

VERTICAL SHAFT IMPACT CRUSHER Model 2500 Spec Sheet

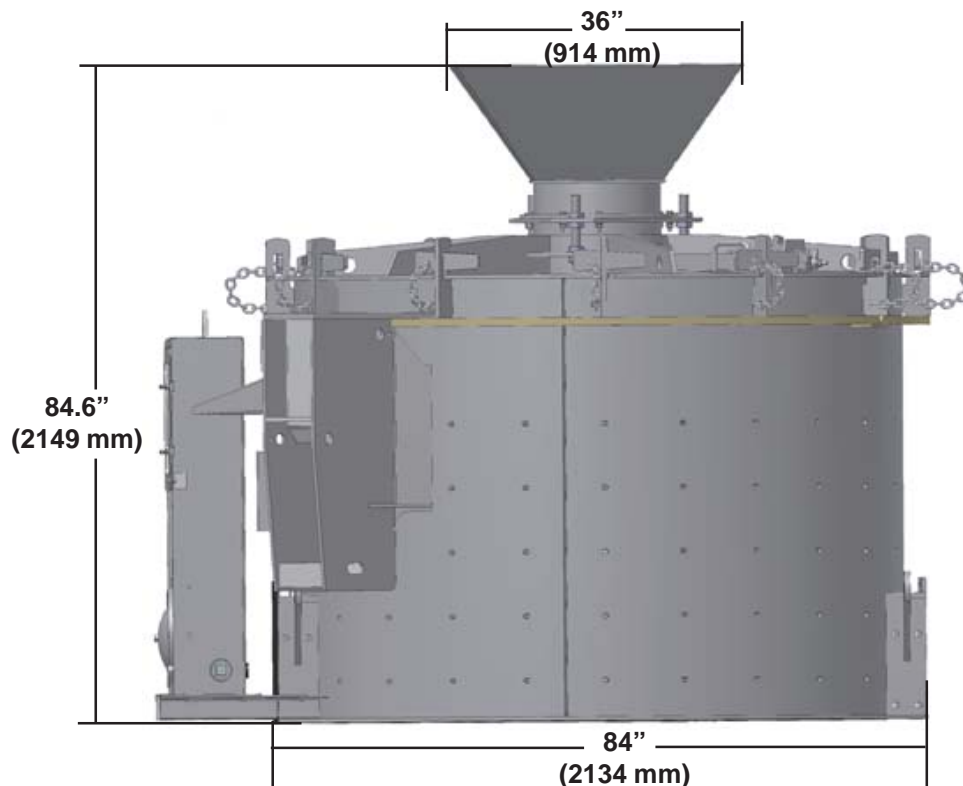

● MAIN FRAME & TUB

- Fabricated steel construction
- Bolt on high chrome liners protect tub and drive tunnel

● FEED MECHANISM

- Externally adjustable fabricated steel feed box
- High chrome replaceable feed tubes

● LID

- Fabricated steel construction with access door
- Bolt on high chrome liners
- Optional hydra-arm lid removal system

● PEDESTAL ASSEMBLY

- Fabricated stress relieved housing
- Tapered roller bearings
- Solid steel 6-1/2" 4142 shaft
- 25-1/2" x 4-3/4" flywheel

● ACCELERATOR

- 3 port rotor and 3, 4, or 5 shoe tables are interchangeable
- 100% replaceable liners
- Fabricated stress relieved construction

● IMPACT AREA

- Hybrid rock shelf and cluster ring are interchangeable
- Fabricated construction
- Replaceable high chrome anvils
- Anvils in rock shelf for higher efficiency

● LUBE SYSTEM

- Self contained low pressure bearing oil lube system
- Pedestal seals are grease lubricated

● **CRUSHER DATA**

Tub Diameter.....72-3/8" (1838 mm)
 Feed Tube.....11-3/8" dia (289mm)
 Accelerator Speed700 to 1400 rpm
 Max Feed Size Rotor.....2" (51mm)
 Max Feed Size Shoe Table.....3" (76mm)

Weight.....18,000 lbs (H) 19,000 lbs (A)
 Explosion Chamber.....10,120 cu in
 Recommended HP150-300 electric
 Capacity.....150-300 tph

Typical Limestone in Standard Configuration 2500H
Producing a course graded material,
Emphasis on chips, popcorn, and dimensional products.

Typical coarse gradations require 50% - 80% maximum speed, 3 or 4 shoe table.

Tertiary		MODEL 2500H					
		3" Feed		2" Feed		1" Feed	
Sieve Size		Typical	Typical	Typical	Typical	Typical	Typical
inches	mm	Feed	Output	Feed	Output	Feed	Output
3"	75mm		100%				
2"	50mm		98		100%		
1 1/2"	37.5mm		94		98		
1"	25mm		83		90		100%
3/4"	19mm		69		78		95
1/2"	12.5mm		52		60		80
3/8"	9.5mm		40		46		62
1/4"	6.3mm		28		33		40
#4M	4.75mm		20		24		30
#8M	2.36mm		14		15		15
#16M	1.18mm		9		10		10
#30M	600uM		6		7		7
#50M	300uM		4		5		5
#100M	150uM		3		4		4
#200M	75uM		2		3		3

Typical Limestone in Standard Configuration 2500 H
Producing a dense graded material, emphasis on fines for base,
asphalt material, sand supplement, etc.

Typically dense gradations require 70% - 100% maximum speed, 4 or 5 shoe table.

Tertiary		MODEL 2500H					
		3" Feed		2" Feed		1" Feed	
Sieve Size		Typical	Typical	Typical	Typical	Typical	Typical
inches	mm	Feed	Output	Feed	Output	Feed	Output
3"	75mm		100%				
2"	50mm		98				
1 1/2"	37.5mm		95		100%		
1"	25mm		87		94		100%
3/4"	19mm		79		85		99
1/2"	12.5mm		68		73		90
3/8"	9.5mm		57		62		78
1/4"	6.3mm		46		49		63
#4M	4.75mm		37		40		52
#8M	2.36mm		26		27		33
#16M	1.18mm		17		18		21
#30M	600uM		11		12		15
#50M	300uM		7		8		10
#100M	150uM		5		6		6
#200M	75uM		4		4		4

Typical Limestone in Standard Configuration 2500 H
Crushing 1" top feed size for chips, popcorn, fracture count, or a
manufactured sweetener.

Low Range Resulting From: - tough feed material - impeller speeds 50-80% of max. - crusher choke-fed - 3 or 4 shoe table

High Range Resulting From: - moderately tough to moderately friable feed material - 4 or 5 shoe table - impeller speeds 80-100% of max. - crusher fed 85% of choke-feed rate, or less

MODEL 2500H		Approx. Crusher Output				
Quaternary		Feed	Low Range	High Range	Average	High Range Screened at #4M*
Sieve Size						
inches	mm			%Passing		
1"	25mm		100%	100%	100%	
3/4"	19mm		95	99	97	
1/2"	12.5mm		80	90	85	
3/8"	9.5mm		62	78	70	
1/4"	6.3mm		40	63	52	
#4M	4.75mm		30	52	41	100%
#8M	2.36mm		15	33	24	75
#16M	1.18mm		10	21	15	48
#30M	600uM		6	15	11	34
#50M	300uM		5	10	7	22
#100M	150uM		4	6	5	13
#200M	75uM		3	4	3	9

* Shows high range with the effect of normal field screening inefficiencies. A proportional return of the coarse screen through fractions and hydraulic classification to remove a portion of the #100 mesh minus is usually required to meet ASTM C-33 specifications regarding a #4M minus gradation.

Typical Sand & Gravel in 2500A
Autogenous & Semiautogenous Configuration

Typical gradations shown use 100% speed, consult factory for speed variation comparison.

MODEL 2500A			Fully Autogenous 100% Speed	Semi-Autogenous 100% Speed
Autogenous		1 1/2" Feed		
Sieve Size				
inches	mm			
2"	50mm			
1 1/2"	37.5mm		100%	
1 1/4"	31mm		99	100%
1"	25mm		95	96
3/4"	19mm		90	90
1/2"	12.5mm		70	76
3/8"	9.5mm		56	58
1/4"	6.3mm		38	45
#4M	4.75mm		31	37
#8M	2.36mm		22	25
#16M	1.18mm		15	17
#30M	600uM		11	13
#50M	300uM		8	8
#100M	150uM		6	5
#200M	75uM		4	3

Feeds: Typical feeds shown have been screened to take out product sized material, and are initial feed plus recirculating load.

Outputs: These outputs show average values based on field experience crushing tough material, and indicate crusher output before screening product sized material out. Gradation change is due to accelerator speed and crusher configuration. Values will differ for each specific crushing application. Factors that can affect output gradation are: feed gradation, feed tonnage, feed friability, crusher configuration, accelerator speed, moisture content, closed circuit screen cloth opening, available screen area and horsepower. Capacities and gradations are based upon material weighing 2,700 lbs. per cubic yard (1600 kg/m³). Capacities may vary as much as ± 25% dependent upon methods of loading, characteristics and gradation of material, condition of equipment and other factors.

NOTE: Specifications are subject to change without notice.

Because KPI-JCI may use in its catalog & literature, field photographs of its products which may have been modified by the owners, products furnished by KPI-JCI may not necessarily be as illustrated therein. Also continuous design progress makes it necessary that specifications be subject to change without notice. All sales of the products of KPI-JCI are subject to the provisions of its standard warranty. KPI-JCI does not warrant or represent that its products meet any federal, state, or local statutes, codes, ordinances, rules, standards or other regulations, including OSHA and MSHA, covering safety, pollution, electrical wiring, etc. Compliance with these statutes and regulations is the responsibility of the user and will be dependent upon the area and the use to which the product is put by the user. In some photographs, guards may have been removed for illustrative purposes only. This equipment should not be operated without all guards attached in their normal position. Placement of guards and other safety equipment is often dependent upon the area and how the product is used. A safety study should be made by the user of the application, and, if required additional guards, warning signs and other safety devices should be installed by the user, wherever appropriate before operating the products.