

SERIES 7000 CLASSIFYING TANK

Model 7112-48 Spec Sheet

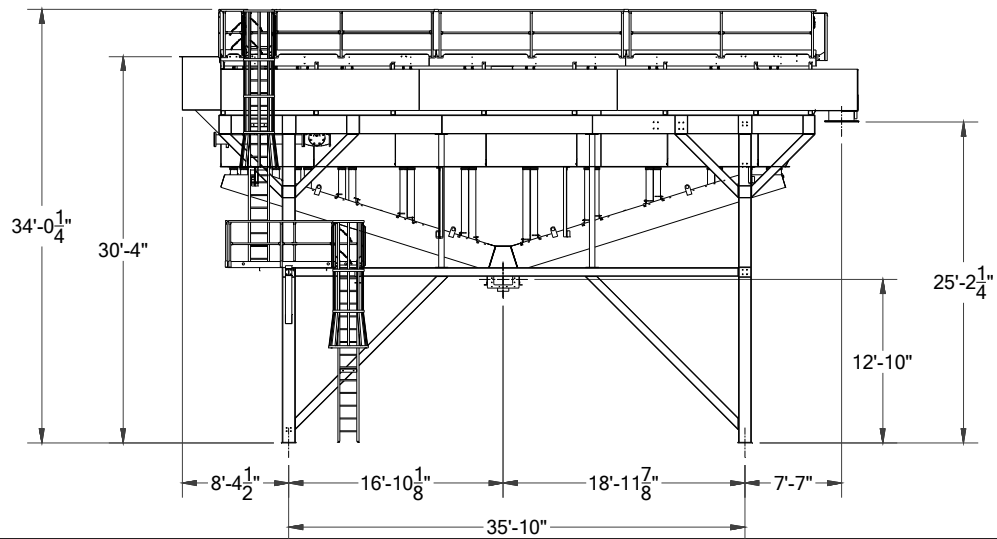
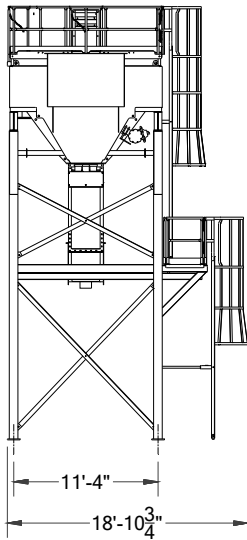
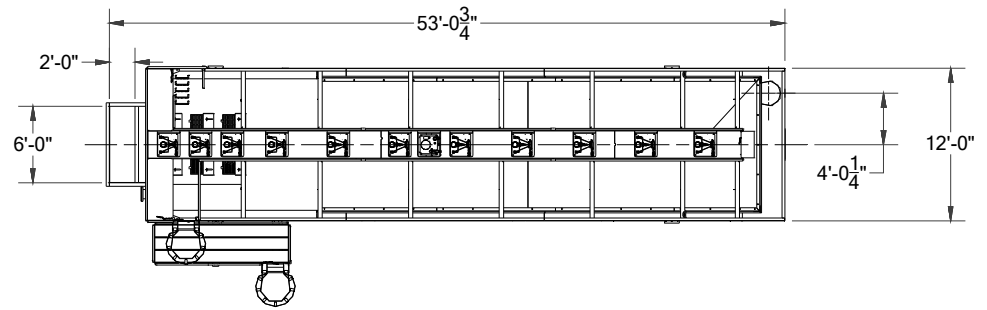

● MAIN TANK & COLLECTING FLUME

- Main tank - 5/16" (sides, ends, overflow launder & feed box) and 3/8" (bottom plate) welded plate steel construction
- Integral feed box with 1/4" AR curved liner and nominal 2' x 6' feed opening
- 80' of adjustable weir boards
- Integral overflow launder with 24" dia. discharge
- Ladder rungs located near the feed end of the tank for internal tank access
- Self-support tank design with external stiffeners only - no internal stiffeners
- Three-cell collecting flume - 1/4" welded plate construction (unlined)
- Center discharge box - 1/4" welded plate construction (unlined)

● WALKWAY & MECHANISM SUPPORT

- 24" wide diamond deck walkway across the feed end and down the center of the tank
- 1-1/2" O.D. posts, top and intermediate handrails
- 4" toeboards
- Removable/hinged door sections at each station
- Walkway support structure also houses and supports the electric/hydraulic operating mechanism

● VALVES, VALVE SEATS, DOWNPIPES & DISCHARGE ELBOWS

- Self-aligning urethane dart valves
- "Snap-in" urethane valve seats
- 6" schedule 40 UV rated PVC downpipes
- Urethane discharge elbows with rectangular discharge

● **OPERATING MECHANISM**

- 3 HP electric/hydraulic power pack with nominal 3 micron filtration
- 750-psi (adjustable to 1,000-psi) hydraulic system
- 10-gal. hydraulic reservoir
- Accumulator
- Eleven (11) settling stations each including:
 - * One (1) 24-volt DC adjustable height sensing paddle assembly
 - * Three (3) discharge valves with adjustable down rods operated by hydraulic cylinders
 - * Hydraulic manifold block with cartridge valves and 24-volt DC coils
 - * Individual ball and check valves
 - * Stainless steel hydraulic plumbing with o-ring face seal fittings
- All stations prewired to a bridge mounted NEMA 4 junction box which also houses the PLC (programmable logic controller)
- All wiring in the form of "plug and receptacle" type cords
- Controller: Standard Dell PC HMI (human-machine-interface) including CPU, monitor, keyboard, optical mouse and Windows™ based programming. An optional industrial PC HMI with touch screen housed in a NEMA 4 enclosure is available for outdoor installations

● **PHYSICAL/OPERATING CHARACTERISTICS**

- Feed Material Size - minus 3/8"
- Capacity - TPH dependent on water requirements for proper feed material dilution and desired material retention
- Water Requirements - up to 8,100 gpm
- Operational Dim. (when installed on standard stationary structure) - 53'2" L x 18'11" W x 34' H
- Loads (when installed on standard stationary structure)
 - Approx. Dead Load = 74,500 lbs.
 - Approx. Live Load = 278,000 lbs.
 - Approx. Tank Volume = 15,648 gallons

● **OPTIONAL EQUIPMENT**

- Three-cell rising current classifier (includes external manifold, individual flow control valves and internal baffling at the first three stations within the classifying tank)
- 8" flanged, pressure reducing/check valve
- Recirculating pump
- AR or urethane liners for the three-cell collecting flume and center discharge box
- Tank-to-screw flumes with AR or urethane liners
- Tank supports - stationary or skid (semi-portable)
- Access - ladder or stairs depending on support configuration
- Flume level walkway (stationary support structure configuration only)
- Model #7212-48: KPI-JCI exclusive system monitoring components that monitor the mechanical, hydraulic and electrical functions of the classifying tank and alert the operator, both locally and remotely, of potentially failed components and/or operational conditions that are outside the normal operating parameters.

SIZE	Overflow Capacity (GPM)			No. Discharge Stations
	#100 MESH	#150 MESH	#200 MESH	
8' x 20'	2300	1200	700	6
8' x 24'	2800	1400	800	7
8' x 28'	3200	1600	900	8
8' x 32'	3500	1800	950	9
10' x 24'	3500	1800	950	7
10' x 28'	4100	2100	1100	8
10' x 32'	4700	2400	1250	9
10' x 36'	5300	2700	1400	10
10' x 40'	5900	3000	1550	11
12' x 48'	8100	4200	2150	11

NOTE: Specifications are subject to change without notice.

Because KPI-JCI may use in its catalog & literature, field photographs of its products which may have been modified by the owners, products furnished by KPI-JCI may not necessarily be as illustrated therein. Also continuous design progress makes it necessary that specifications be subject to change without notice. All sales of the products of KPI-JCI are subject to the provisions of its standard warranty. KPI-JCI does not warrant or represent that its products meet any federal, state, or local statutes, codes, ordinances, rules, standards or other regulations, including OSHA and MSHA, covering safety, pollution, electrical wiring, etc. Compliance with these statutes and regulations is the responsibility of the user and will be dependent upon the area and the use to which the product is put by the user. In some photographs, guards may have been removed for illustrative purposes only. This equipment should not be operated without all guards attached in their normal position. Placement of guards and other safety equipment is often dependent upon the area and how the product is used. A safety study should be made by the user of the application, and, if required additional guards, warning signs and other safety devices should be installed by the user, wherever appropriate before operating the products.



700 W 21st. St., Yankton, SD 57078
1-800-542-9311 Fax: 605-665-8858

Email: mail@kpijci.com
www.kpijci.com
Mdl 7112-48 Rev.3 02/10