

Operational Mode

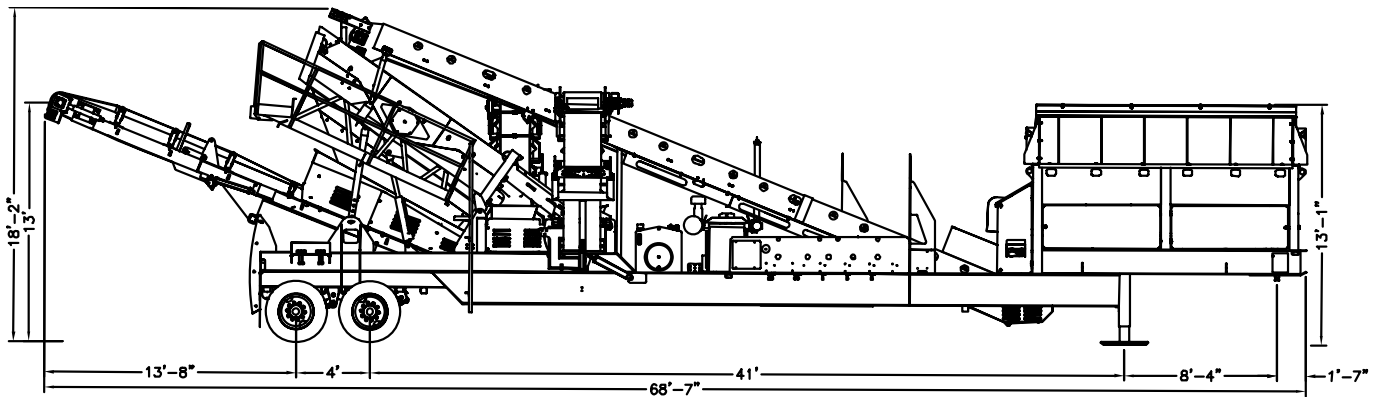

Transportation Mode

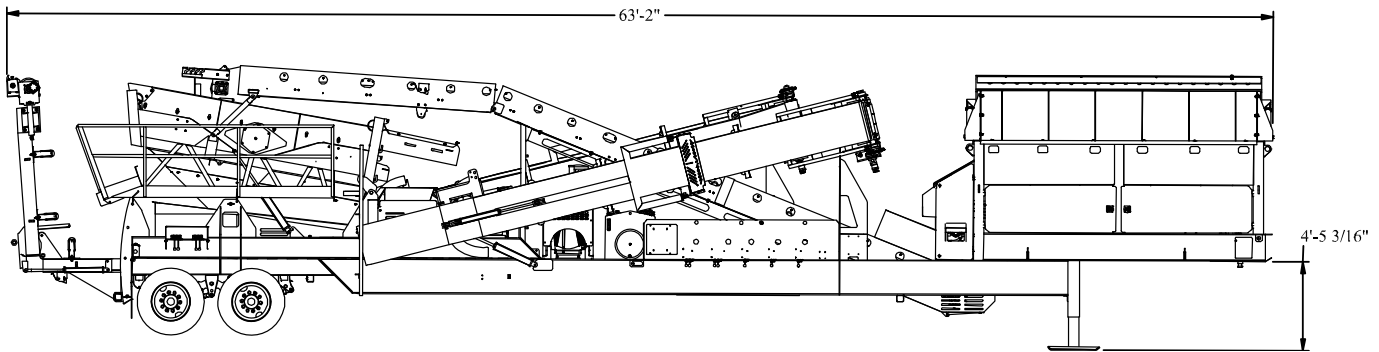

DELIVERY CONVEYOR

- One (1) 38' x 36" conveyor with hydraulic drive (350 FPM)
- 12" self cleaning wing pulley
- Belting is 220 PIW, 1/8 x 1/16 cover

SIDE CONVEYOR

- Two (2) 27' x 24" swing out conveyors with hydraulic variable speed drive (0-350 FPM)
- Receiving hopper for both conveyors
- 10" self cleaning pulley
- Belting is 220 PIW, 1/8 x 1/16 cover

FINES CONVEYOR

- One (1) 23' x 42" conveyor with hydraulic drive (350 FPM)
- 8" channel
- Discharge height is 8'-4" or 13'-7"
- Belting is 220 PIW, 1/8 x 1/16 cover

CHASSIS

- 21" I-beam with king pin type hitch
- Hydraulic landing gear for leveling of plant
- Tandem axle assembly with eight (8) 11R22.5 tires and mud flaps
- Leaf spring suspension, air brakes, rear tail lights

FEEDER

- 14' x 42" belt feeder with hydraulic variable speed drive (0-60 FPM)
- 11" formed channel
- 12" self-cleaning wing pulley
- Belting is 330 PIW, 3/16 x 1/16 cover

POWER SYSTEM

- 99 HP Tier IV John Deere water cooled diesel
- 12 volt battery

NOTE: Specifications are subject to change without notice.

- Engine mounted hydraulic pumps to operate all plant functions and two (2) off-plant hydraulically driven conveyors

- NEMA-4 rated instrument panel

- Emergency stops

VIBRATING SCREEN

- One (1) 2512K double deck Kolberg® screen
- 5' x 12' screen top and bottom deck
- Top and bottom deck driven by 1200 RPM vibrating mechanism mounted on screen
- Hydraulic controls for variable angle operation
- Top and bottom discharge chutes
- Aggregate spreader, fixed access ladder with wrap around walkway

HOPPER

- 12 cubic yard heaped capacity
- 6' x 13' top opening
- Heavy duty 25° sloped grizzly with 6" openings
- Hydraulic dump with scissor action for easy cleaning

PLANT CAPACITY

- 350 TPH (tonnages will vary with conditions)

PAINT

- One primer coat, finish coat of KPI Beige

SERVICE CAPACITY

- 140 gal. fuel tank
- 150 gal. hydraulic system with return filters

OPTIONS

- Bulkhead assisting ramping for loader feed to feed hopper
- Remote control grizzly
- Wings for funneling feed material onto feed hopper
- Hammermill shredder
- Standard Steel Screen Cloth for 2512K
- CONSULT FACTORY FOR ADDITIONAL OPTIONS

PHYSICAL OPERATION CHARACTERISTICS

- Overall Length.....68'7"/20.94m
- Travel Length.....63'2"/19.26m
- Operating Height.....18'2"/5.56m
- Travel Height.....13'/3.96m
- Operating Width.....46'7"/14.23m
- Travel Width.....11'2"/3.4m
- Unit Weight.....57,400lbs/26,036kg



2704 West LeFevre Road
 Sterling, IL 61081
 Phone: (815) 626-6374
 FAX: (815) 626-6430
mail@kpijci.com
www.kpijci.com

NOTE: Specifications are subject to change without notice.

Because Astec Mobile Screens may use in its catalog & literature, field photographs of its products which may have been modified by the owners, products furnished by Astec Mobile Screens may not necessarily be as illustrated therein. Also continuous design progress makes it necessary that specifications be subject to change without notice. All sales of the products of Astec Mobile Screens are subject to the provisions of its standard warranty. Astec Mobile Screens does not warrant or represent that its product meet and federal, state, or local statutes, codes, ordinances, rules, standards or other regulations, including OSHA and MSHA, covering safety, pollution, electrical wiring, etc. Compliance with these statutes and regulations is the responsibility of the user and will be dependent upon the areas and the use to which the product is put by the user. In some photographs, guards may have been removed for illustrative purposes only. This equipment should not be operated without all guards attached in their normal position. Placement of guards and other safety equipment is often dependent upon the area and the use to which the product is put. A safety study should be made by the user of the application, and, if required additional guards, warning signs and other safety devices should be installed by the user, wherever appropriate before operating the products.