

TRACK MOUNTED JAW PLANT Model FT3055 Spec Sheet

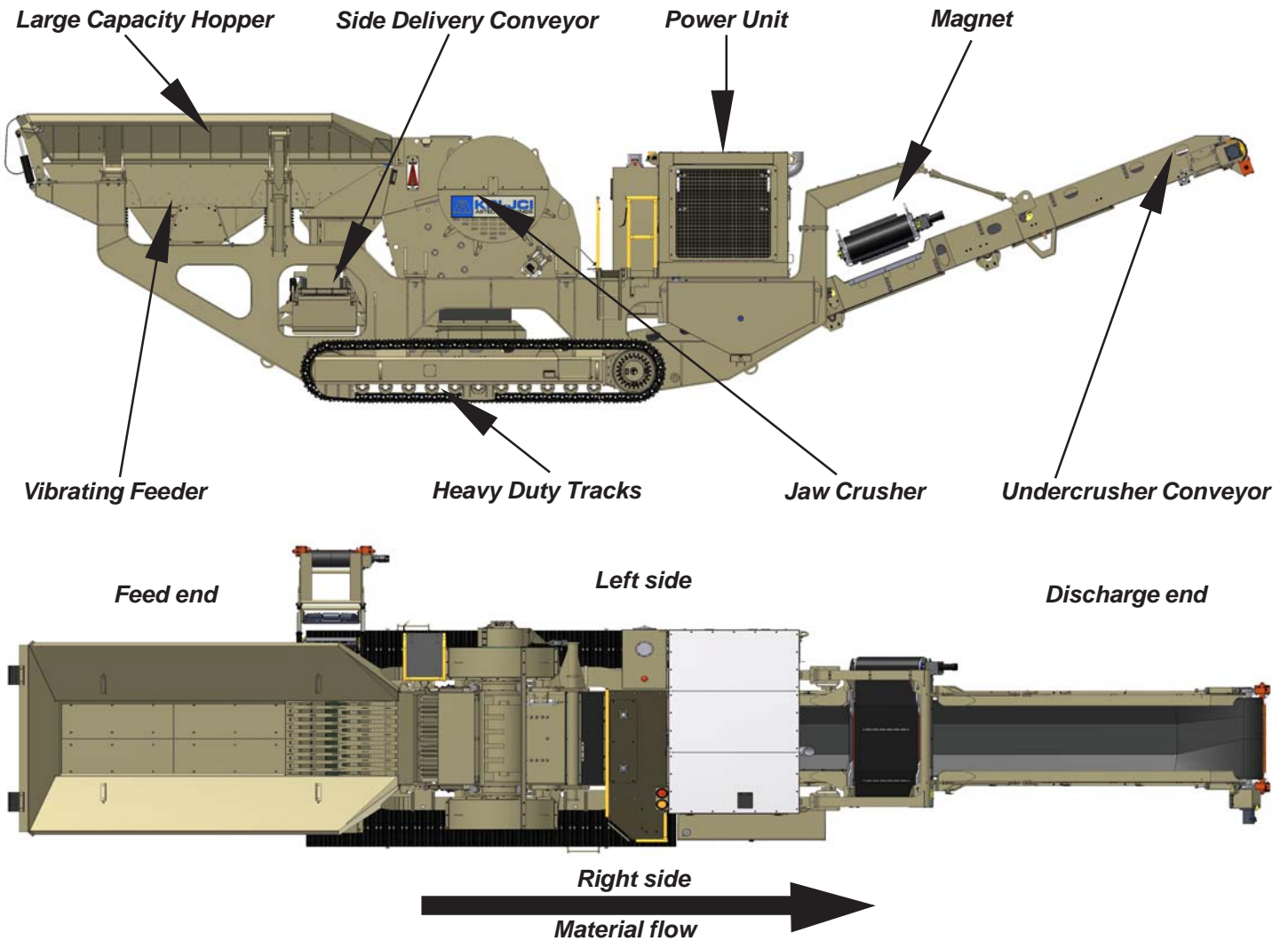

- **VIBRATING GRIZZLY FEEDER**

- 50" X 15' Vibrating Pan Feeder
- 9.5 Cubic yard Hopper with folding walls
- 5' Step deck grizzly bars 2-1/2" spacing

- **JAW CRUSHER**

- 3055 Vanguard Jaw
- Hydraulically adjustable
- Hydraulically driven and reversible

- **CHASSIS**

- Sculpted I-beam frame design
- 600mm tracks with dual drive
- Track width 11'3"/3.429m
- Balanced for zero cribbing
- 185 gal/700.3 L Oil Reservoir

- **UNDERCRUSHER CONVEYOR**

- 48" x 42' Under crusher conveyor
- Impact bed with 330 3ply belting
- Easily removed for maintenance

- **POWER UNIT**

- Cat C13 440hp/328 kw Tier IV i
- Cat C13 440hp/328 kw Tier III (International)
- 190gal/719L fuel tank
- Fuel consumption 15-18 Gal/Hr

- **OPTIONS**

- 24" x 12' Side delivery conveyor
- Permanent cross belt magnet
- 440piw single ply belting
- Dust suppression
- 50" x 18' Vibrating Feeder
- Electrical/Hydraulic Control Valve (CE Certification)

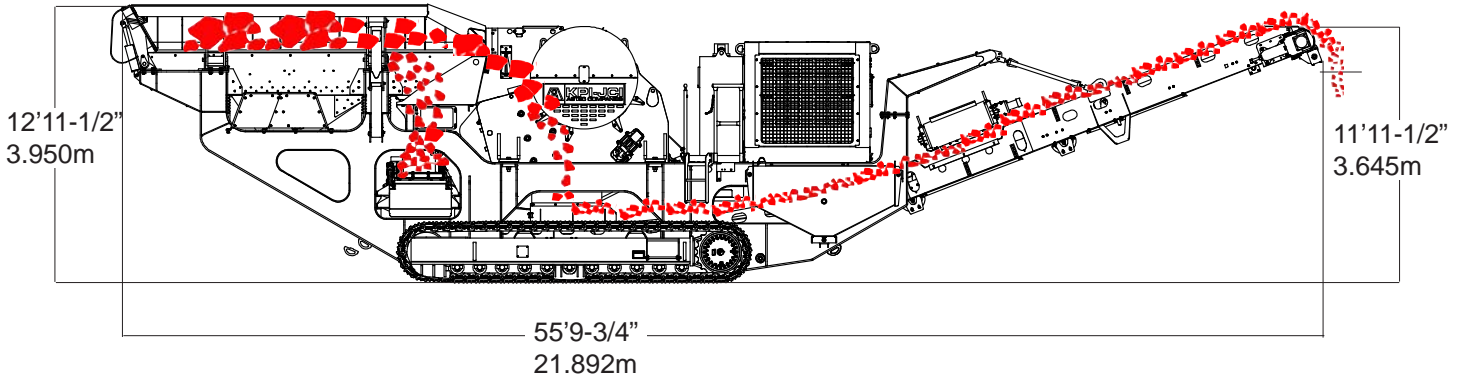

● **CRUSHER**

Max Feed Size..... 24\"/>

● **PHYSICAL/OPERATING CHARACTERISTICS**

Overall Length.....	55' 9-3/4\"/>
Operating Height.....	12' 11-1/2\"/>
Travel Height.....	11' 11-1/2\"/>
Ground Clearance.....	10 -1/2\"/>
Travel Width.....	11' 9-1/2\"/>
Feed Height.....	12' 11-1/2\"/>
Discharge Height.....	10' 2-3/4\"/>
Unit Weight.....	124,000 lbs/56,245kg

● **OPERATING SLOPE**

Side to Side..... 1% grade Front to Back.....3% grade

● **PERFORMANCE WHEN MOVING**

Travel Speed.....	.60MPH	Gradability.....	50%
Total Tractice Effort.....	70,519 lbf	Ground Pressure.....	2415PSF

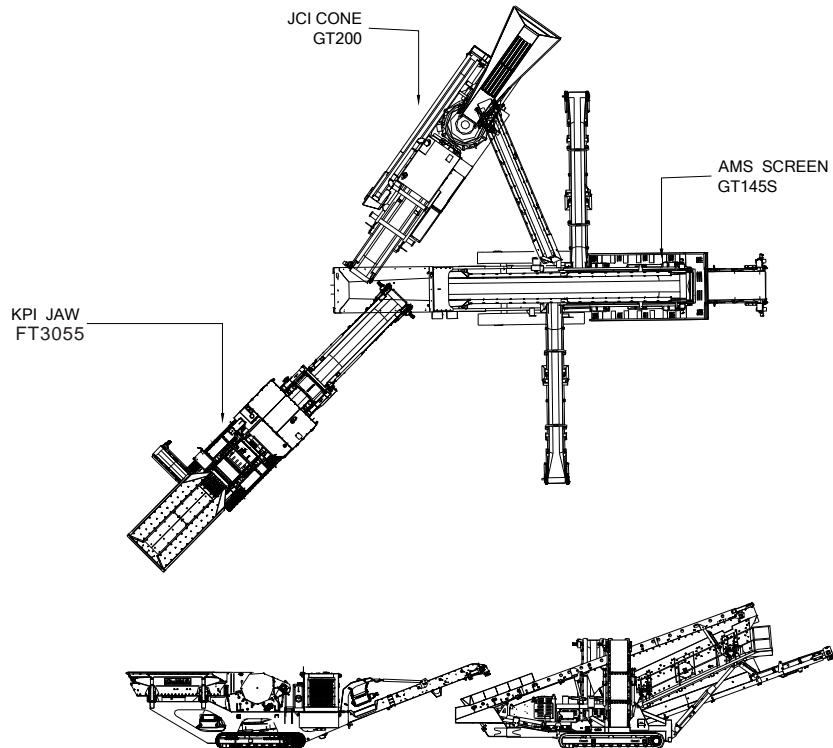

NOTE: Specifications are subject to change without notice.

Because KPI-JCI may use in its catalog & literature, field photographs of its products which may have been modified by the owners, products furnished by KPI-JCI may not necessarily be as illustrated therein. Also continuous design progress makes it necessary that specifications be subject to change without notice. All sales of the products of KPI-JCI are subject to the provisions of its standard warranty. KPI-JCI does not warrant or represent that its products meet any federal, state, or local statutes, codes, ordinances, rules, standards or other regulations, including OSHA and MSHA, covering safety, pollution, electrical wiring, etc. Compliance with these statutes and regulations is the responsibility of the user and will be dependent upon the area and the use to which the product is put by the user. In some photographs, guards may have been removed for illustrative purposes only. This equipment should not be operated without all guards attached in their normal position. Placement of guards and other safety equipment is often dependent upon the area and how the product is used. A safety study should be made by the user of the application, and, if required additional guards, warning signs and other safety devices should be installed by the user, wherever appropriate before operating the products.



700 W 21st. St., Yankton, SD 57078
 1-800-542-9311 Fax: 605-665-8858

Email: mail@kpijci.com
 www.kpijci.com
 Mdl FT3055 10/11 rev 1