

Operational Mode

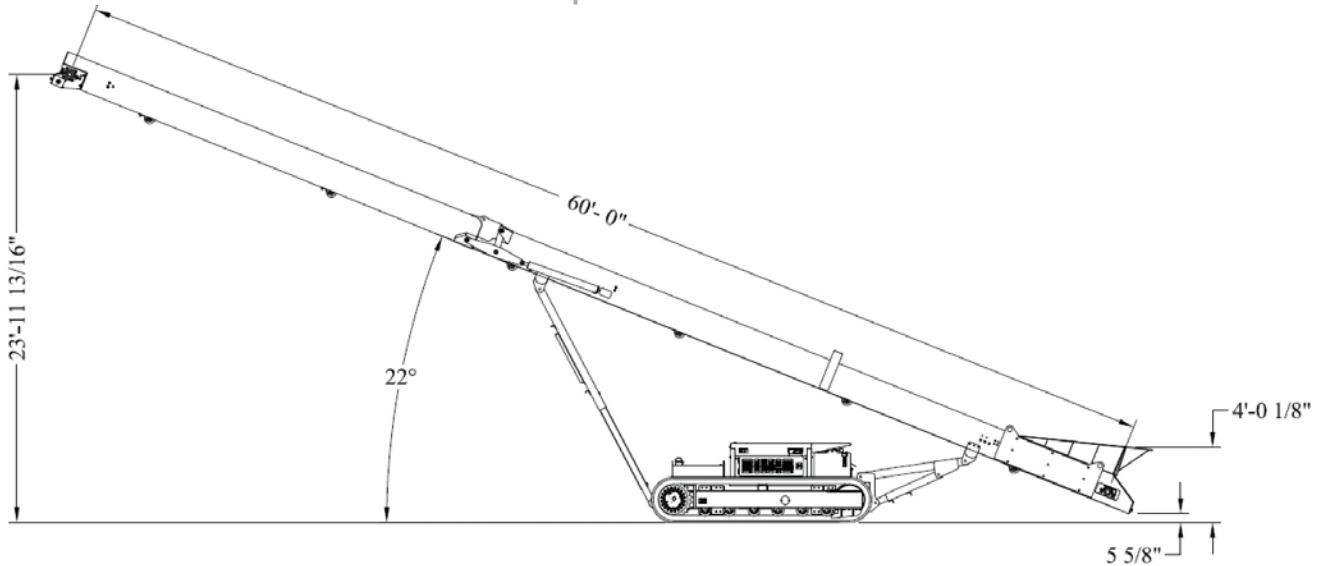

Transportation Mode

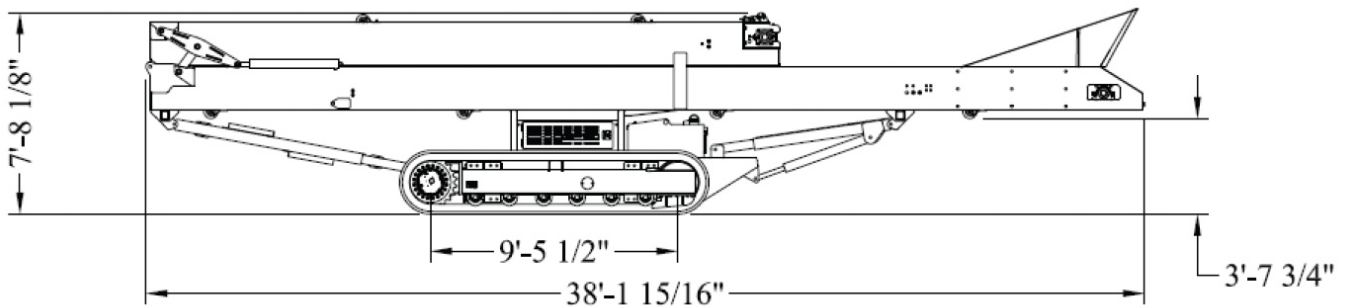

MAIN CONVEYOR

- 60'-0" x 36"
- Troughing idlers mounted on 4'-0" centers & 1'-0" centers in loading area
- 10" self-cleaning winged type tail pulley
- Variable speed hydraulic drive
- 10" self cleaning pulley
- Primary belt cleaner with internal spring tensioner

FRAME

- Track mounted frame constructed of formed plate
- Enclosed power section with hinged access doors

- Heavy Duty fold down with protection for cylinders
- Both head and tail end of conveyor are able to be hydraulically raised

POWER AND HYDRAULICS

- Caterpillar 60 HP Tier IV water cooled diesel engine
- 50 gallon fuel tank
- Oil Cooler; Engine mounted hydraulic pump to operate all plant functions
- 85 gallon hydraulic reservoir with return filter
- Hydraulic operated tracks with pendant remote control (wireless optional)

NOTE: Specifications are subject to change without notice.

- NEMA-4 rated instrument panel; hour meter; emergency stops

PLANT CAPACITY

- 750 TPH (tonnages will vary with conditions)

PAINT

- One primer coat, finish coat of KPI Beige

OPTIONS

- Wireless track remote
- Dust cover
- Impact bed in feed area
- Dust suppression

- Full length skirt boards
- Belt scale
- 1/2 Hardox Hopper Liners
- CONSULT FACTORY FOR ADDITIONAL OPTIONS

PHYSICAL OPERATION CHARACTERISTICS

- Overall Length.....62'/18.90m
- Travel Length.....38'2"/11.64m
- Operating Height.....24'/7.32m
- Travel Height.....7'8"/2.38m
- Operating Width.....7'7"/2.35m
- Travel Width.....7'7"/2.35m
- Unit Weight.....29,000lbs/13,154 kg



2704 West LeFevre Road
 Sterling, IL 61081
 Phone: (815) 626-6374
 FAX: (815) 626-6430
mail@kpijci.com
www.kpijci.com

NOTE: Specifications are subject to change without notice.

Because Astec Mobile Screens may use in its catalog & literature, field photographs of its products which may have been modified by the owners, products furnished by Astec Mobile Screens may not necessarily be as illustrated therein. Also continuous design progress makes it necessary that specifications be subject to change without notice. All sales of the products of Astec Mobile Screens are subject to the provisions of its standard warranty. Astec Mobile Screens does not warrant or represent that its product meet and federal, state, or local statutes, codes, ordinances, rules, standards or other regulations, including OSHA and MSHA, covering safety, pollution, electrical wiring, etc. Compliance with these statutes and regulations is the responsibility of the user and will be dependent upon the areas and the use to which the product is put by the user. In some photographs, guards may have been removed for illustrative purposes only. This equipment should not be operated without all guards attached in their normal position. Placement of guards and other safety equipment is often dependent upon the area and the use to which the product is put. A safety study should be made by the user of the application, and, if required additional guards, warning signs and other safety devices should be installed by the user, wherever appropriate before operating the products.