



# KODIAK PLUS CONE CRUSHERS Specification Sheet



\*Crushers shown without standard sheave

- **CRUSHER**

- High efficiency roller bearing design
- Remote Close Side Setting (CSS) adjustment
  - Digital read out setting control
  - Patented "gall resistant" brass bowl threads
  - Patented "no creep" bowl clamp
- Patented mechanical "crusher duty" cone brake
  - K200+, K300+, K400+
  - Hydraulic Cone Brake Std on K500+
- Patented liner retention assembly
- Low impact Tramp Iron Relief (TIR) system
  - Pressure relief valves
  - Large bore heavy duty relief cylinders
  - Hydraulic "one button" chamber clearing
- Bronze field replaceable V-Seat liners
- Permanently precision balanced
- Protected internal counter weights
- Baseframe tub liners field replaceable 400BHN
- Cold climate oil recirculation
- Manganese liners (Select from list of interchangeable liners)
- Crusher tools
- Operation and Maintenance manuals
- Crusher Feed Hopper

- **HYDRAULIC POWER UNIT**

- 25 gal (94.6L) reservoir (Filled at the factory)
- 15HP (11kW) TEFC motor
- 6 gpm (23Lpm)
- Remote control panel w/ 50' cable

- **OIL COOLER**

- 1HP (.75kW) TEFC motor

- **LUBE ASSEMBLY**

- 3HP (2.2kW) TEFC motor
- 2 X 1500W heaters
- Automatic oil cooler bypass
- Oil flow sensor

- **KODIAK+ PLC BASED CRUSHER CONTROL (MILO)**

- Auto control of crusher lube functions
- Auto control of crusher hydraulic functions
- Interlocked lube/hydraulic protection
- Integration with existing plant controls
- Feed hopper monitor
- Cold weather overnight oil circulation
- Assistance for specialized maintenance
- Assistance for specialized adjustments
- "On-line" access to all sensors
- Bowl float monitor (optional)
- Liner wear monitoring
- Extensive self diagnostic function

- **CRUSHER OPTIONS**

- V-Belt Drive
- Cogged belt drive
- Longer remote cables (100', 150', 200')
- Hopper extension with overflow chute
- Hydraulic cone brake (K200+, K300+, K400+)
- Bowl float monitor
- Kidney loop auxiliary lube filtration
- Electric Motor(s)

## Kodiak Plus Dimensions

	K200+	K300+	K400+	K500+
<b>A</b>	79.875 in 2029 mm	83.125 in 2111 mm	90.25 in 2292 mm	96.688 in 2456 mm
<b>B</b>	73.875 in 1876 mm	77.75 in 1975 mm	85.125 in 2162 mm	90.188 in 2291 mm
<b>C</b>	65.5 in 1664 mm	68.25 in 1734 mm	75.375 in 1915mm	78.438 in 1992 mm
<b>D</b>	40.313 in 1024 mm	41 in 1041 mm	46.25 in 1175 mm	51 in 1295mm
<b>E</b>	53.52 in 1359 mm	56.52 in 1436mm	62.125 in 1578 mm	68.875 in 1749 mm
<b>F</b>	75.375 in 1915 mm	79.75 in 2026 mm	85.25 in 2165mm	93.938 in 2386 mm
<b>G</b>	38.875 in 987 mm	42 in 1067 mm	44.5 in 1130 mm	49.5 in 1257 mm
<b>H</b>	77.5 in 1969 mm	84 in 2134 mm	89 in 2261 mm	97.5 in 2476 mm
<b>I</b>	38.875 in 987 mm	42 in 1067 mm	44 in 1130 mm	48.75 in 1238 mm
<b>J</b>	42 in 1067 mm	46 in 1168 mm	46.25 in 1175 mm	50.80 in 1473 mm
<b>L</b>	52 in 1321 mm	55 in 1397 mm	59 in 1499 mm	65 in 1651 mm
<b>M</b>	26 in 660 mm	27.5 in 699 mm	29.5 in 749 mm	32.5 in 825.5 mm
<b>N</b>	63.25 in 1607 mm	69.5 in 1765 mm	74 in 1880 mm	81.5 in 2070.1 mm
<b>O</b>	26 in 660 mm	27.5 in 699 mm	29.5 in 749 mm	32.5 in 825.5 mm
<b>P</b>	52 in 1321 mm	55 in 1397 mm	59 in 1499 mm	65 in 1651 mm

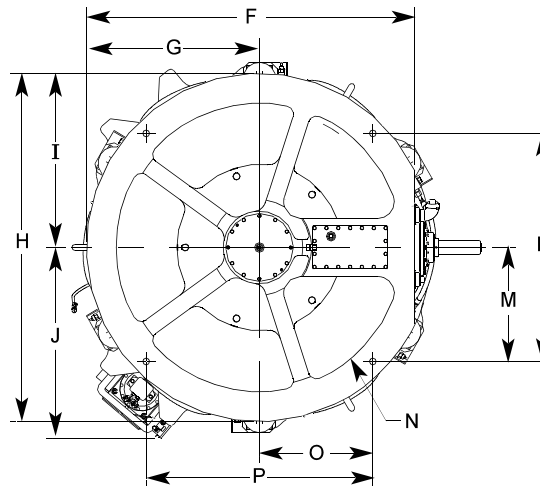
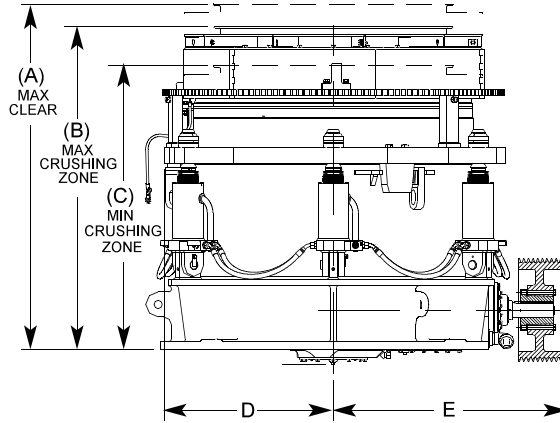

**BOTTOM VIEW**

	K200+	K300+	K400+	K500+
HEAD DIAMETER	40 IN 1016 mm	45 IN 1143 mm	54 in 1372 mm	60 in 1524 mm
OPERATING RANGE	800 – 950 rpm	800 – 950 rpm	800 – 950 rpm	750 – 850 rpm
HORSEPOWER	200 150 kw	300 225 kw	400 300 kw	500 373 kw
TOTAL WEIGHT	34,000 lbs 15,422 kg	41,295 lbs 18,731kg	52,111 lbs 23,637 kg	75,500 lbs 34,246 kg
UPPER ASSEMBLY WITH LINER	12,560 lbs 5697 kg	18,476 lbs 8381 kg	19,350 lbs 8777 kg	26,650 lbs 12,088 kg
LOWER ASSEMBLY WITH MANTLE & SHEAVE	20,300 lbs 9208 kg	23,552 lbs 10,683 kg	31,300 lbs 14,197 kg	48,000 lbs 21,772 kg

**FOR MORE INFORMATION CALL 1-800-314-4656 AND ASK FOR A JCI EQUIPMENT SPECIALIST**

**Note:** Specifications are subject to change without notice.

Because KPI-JCI may use in its catalog & literature, field photographs of its products which may have been modified by the owners, products furnished by KPI-JCI may not necessarily be as illustrated therein. Also continuous design progress makes it necessary that specifications be subject to change without notice. All sales of the products of KPI-JCI are subject to the provisions of its standard warranty. KPI-JCI does not warrant or represent that its products meet any federal, state, or local statutes, codes, ordinances, rules, standards or other regulations, including OSHA and MSHA, covering safety, pollution, electrical wiring, etc. Compliance with these statutes and regulations is the responsibility of the user and will be dependent upon the area and the use to which the product is put by the user. In some photographs, guards may have been removed for illustrative purposes only. This equipment should not be operated without all guards attached in their normal position. Placement of guards and other safety equipment is often dependent upon the area and how the product is used. A safety study should be made by the user of the application, and, if required additional guards, warning signs and other safety devices should be installed by the user, wherever appropriate before operating the products



700 W 21st. St., Yankton, SD 57078  
1-800-542-9311 Fax: 605-665-8858

Email: [mail@jcieug.com](mailto:mail@jcieug.com)  
[www.kpijci.com](http://www.kpijci.com)

Kodiak Plus Crushers Rev A (M11 O) 06/12 Printed in USA