

**Operational Mode**

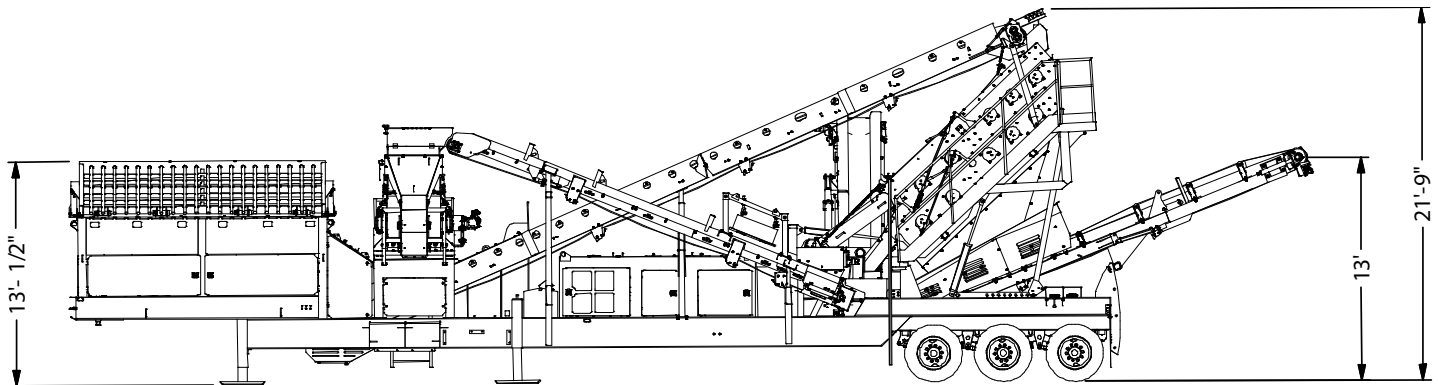

**Transportation Mode**

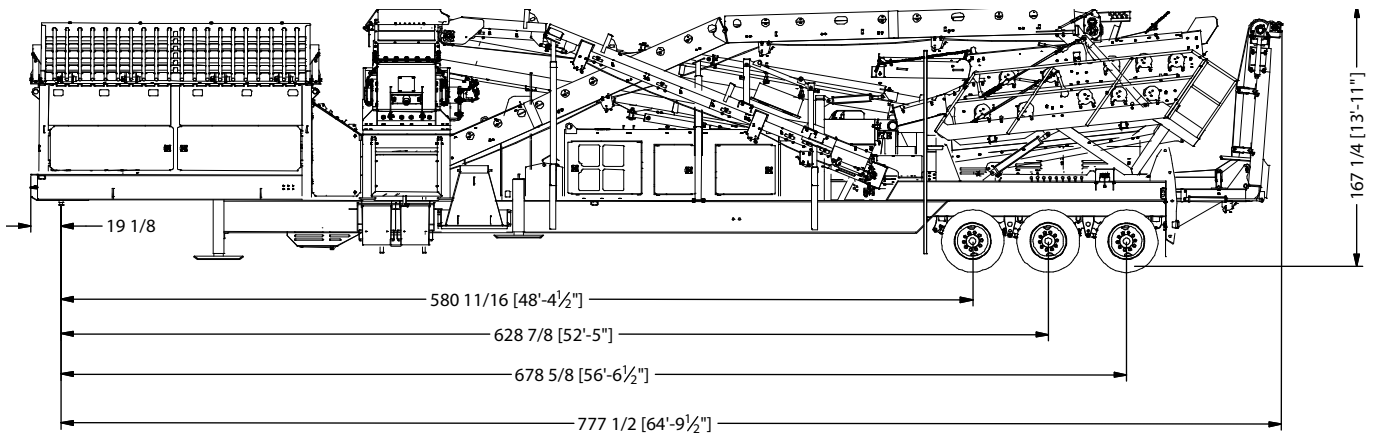

**DELIVERY CONVEYOR**

- One (1) 43' x 36" conveyor hydraulic drive (350 FPM)
- 12" self cleaning wing pulley
- Belting is 330 PIW, 3/16 x 1/16 cover – 1/2" cleat

**SIDE CONVEYOR**

- One (1) 33' x 24" conveyor
- Hydraulic variable speed (0-350 FPM)
- 10" self cleaning pulley
- Belting is 220 PIW, 1/8 x 1/16 cover

**FINES CONVEYOR**

- One (1) 23' x 42" conveyor hydraulic drive (350 FPM)
- Operates at: 8'-4" or 13-7"
- Belting is 220 PIW, 1/8 x 1/16 cover

**CRUSHER RETURN CONVEYOR**

- One (1) 24' x 24" conveyor with hydraulic drive (350 FPM)
- 10" self-cleaning wing pulley
- Belting is 330 PIW, 3/16 x 1/16 cover – 5/8" cleat

**CROSS CONVEYOR**

- One (1) 5' x 18" flat conveyor with hydraulic drive (350 FPM)
- Belting is 330 PIW, 3/16" x 1/16" cover

**NOTE:** Specifications are subject to change without notice.

## FEEDER

- 11" formed channel
- 14' x 32" belt feeder
- Hydraulic variable speed drive (0-60 FPM)
- 330 PIW belting
- 3/16 x 1/16 cover

## CHASSIS

- 24" I-beam with king pin type hitch
- Hydraulic landing gear for leveling of plant
- Twelve (12) 11 R22.5 tires and mud flaps
- Leaf spring suspension, air brakes, rear tail lights

## POWER SYSTEM

- 173 HP Tier IV John Deere water cooled diesel engine
- 12 volt battery
- Engine mounted hydraulic pumps to operate all plant functions
- NEMA-4 rated instrument panel
- Emergency stop

## VIBRATING SCREEN

- One (1) 2612V double deck PEP Vari-Vibe® high-frequency screen
- 6' x 12' high-frequency screen top and bottom deck
- Top and bottom deck are driven by ten (10) variable speed hydraulic vibrators (0-4200 RPM) mounted below screens for directly induced vibrating action
- Hydraulic controls for variable angle operation
- Top and bottom discharge chutes
- Aggregate spreader, step type walkway with ladder

## HOPPER

- 12 cubic yard heaped capacity
- 6' x 13' top opening

- Heavy duty 25° sloped grizzly with 4" x 10" openings
- Hydraulic dump with scissor action for easy cleaning

## PLANT CAPACITY

- 200 TPH (tonnages will vary with conditions)

## PAINT

- One primer coat, finish coat of KPI Beige

## CRUSHER

- 3136 Horizontal Shaft Impact Crusher with heavy fabricated steel plate housing
- Direct coupled hydraulic drive; Hydraulic assist apron opening
- Abrasion resistant steel housing liners

## SERVICE CAPACITY

- 140 gal. fuel tank
- 150 gal. hydraulic reservoir

## OPTIONS

- Bulkhead assisting ramping for loader feed to feed hopper
- Remote control grizzly
- Bypass chute system
- Oversize Return Conveyor Belt Magnet
- Ground Level E-Stop (2 ea.)
- CONSULT FACTORY FOR ADDITIONAL OPTIONS

## PHYSICAL OPERATION CHARACTERISTICS

- Overall Length.....71'11"/21.67m
- Travel Length.....66'9"/20.39m
- Operating Height.....21'9"/6.68m
- Travel Height.....13'11"/3.99m
- Operating Width.....44'/13.41m
- Travel Width.....11'11"/3.39m
- Unit Weight.....82,000lbs/37,195 kg



2704 West LeFevre Road  
Sterling, IL 61081  
Phone: (815) 626-6374  
FAX: (815) 626-6430  
[mail@kpijci.com](mailto:mail@kpijci.com)  
[www.kpijci.com](http://www.kpijci.com)

### NOTE: Specifications are subject to change without notice.

Because Astec Mobile Screens may use in its catalog & literature, field photographs of its products which may have been modified by the owners, products furnished by Astec Mobile Screens may not necessarily be as illustrated therein. Also continuous design progress makes it necessary that specifications be subject to change without notice. All sales of the products of Astec Mobile Screens are subject to the provisions of its standard warranty. Astec Mobile Screens does not warrant or represent that its product meet and federal, state, or local statutes, codes, ordinances, rules, standards or other regulations, including OSHA and MSHA, covering safety, pollution, electrical wiring, etc. Compliance with these statutes and regulations is the responsibility of the user and will be dependent upon the areas and the use to which the product is put by the user. In some photographs, guards may have been removed for illustrative purposes only. This equipment should not be operated without all guards attached in their normal position. Placement of guards and other safety equipment is often dependent upon the area and the use to which the product is put. A safety study should be made by the user of the application, and, if required additional guards, warning signs and other safety devices should be installed by the user, wherever appropriate before operating the products.