

Operational Mode

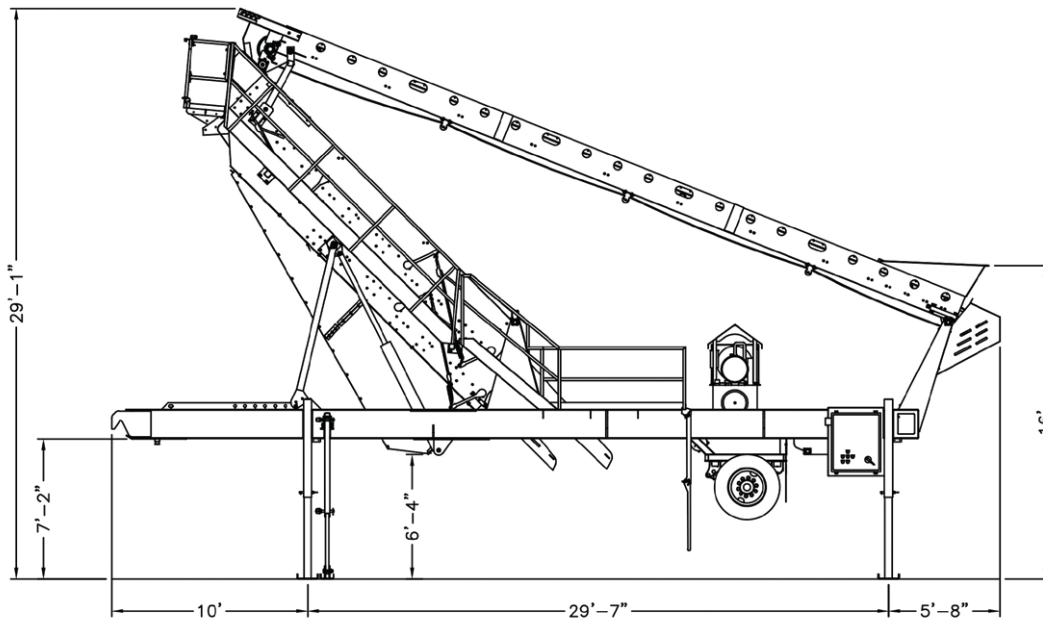

Transportation Mode

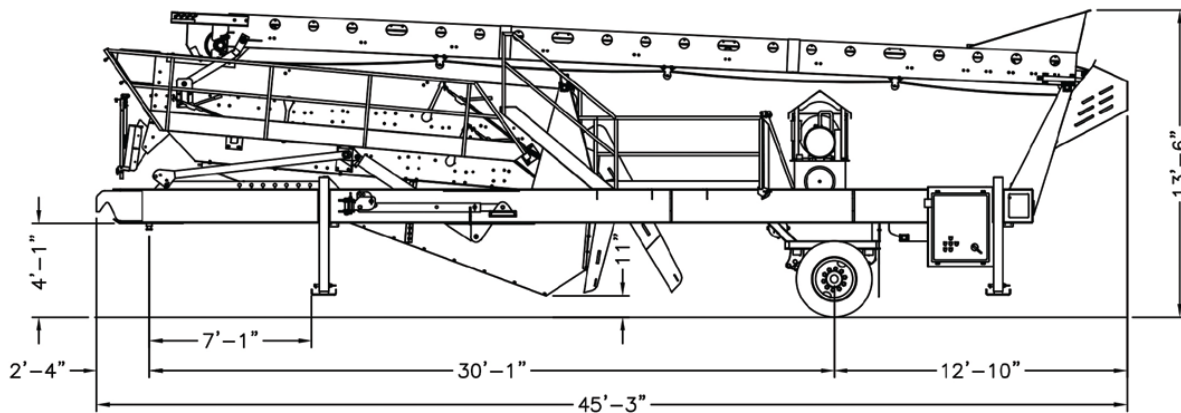

DELIVERY CONVEYOR

- 38'x36" conveyor with variable speed hydraulic drive
- 5' long receiving hopper; 16' loading height
- 14" self-cleaning wing pulley
- Belting is 220 PIW, 1/8 x 1/16 cover; Vulcanized

CHASSIS

- I-Beam type; W18 x 35#
- King pin type hitch
- Four (4) 11 R22.5 tires and mud flaps
- Adjustable height; Outriggers for additional support
- Leaf spring type suspension; Air brakes; Rear tail lights and side marker lights

NOTE: Specifications are subject to change without notice.

POWER,ELECTRICAL & HYDRAULIC

- 50 HP electric motor, 480 Volt, 1750 RPM TEFC
- 80 gallon electric/hydraulic power unit
- Direct coupled variable volume pressure compensated piston pump
- Low oil level shut off switch and warning strobe lights
- NEMA-4 rated instrument panel to operate all electrical functions of plant; off plant power must be provided by customer

VIBRATING SCREEN

- One (1) 2618VM modified double deck PEP Vari-Vibe® high-frequency screen
- 6' x 18' top deck and 6' x 12' bottom deck high-frequency screens
- Top and bottom deck are driven by eleven (11) hydraulic vibrators (0-4200 RPM) mounted below screens for directly induced vibrating action; All vibrators have five (5) force amplitude settings on adjustable slip counter weights
- Hydraulic controls for variable angle operation
- Top and bottom discharge chutes
- Aggregate spreader, access ladder with wrap around walkway

- Fines collecting hopper

MATERIAL RANGE

- 1" to 30M

PLANT CAPACITY

- 350 TPH (tonnages will vary with conditions)

PAINT

- One primer coat, finish coat of KPI Beige

OPTIONS

- (4) Hydraulic legs for raising plant
- (3) HP Starters
- Vinyl dust cover
- Standard steel screen cloth for 2618VM
- Immersion heater
- CONSULT FACTORY FOR ADDITIONAL OPTIONS

PHYSICAL OPERATION CHARACTERISTICS

- Overall Length.....45'5"/13.87m
- Travel Length.....45'3"/13.81m
- Operating Height.....29'1"/8.87m
- Travel Height.....13'6"/4.15m
- Operating Width.....20'6".10m
- Travel Width.....11'11"/3.63m
- Unit Weight.....28,000lbs/12,701kg



2704 West LeFevre Road
 Sterling, IL 61081
 Phone: (815) 626-6374
 FAX: (815) 626-6430
mail@kpijci.com
www.kpijci.com

NOTE: Specifications are subject to change without notice.

Because Astec Mobile Screens may use in its catalog & literature, field photographs of its products which may have been modified by the owners, products furnished by Astec Mobile Screens may not necessarily be as illustrated therein. Also continuous design progress makes it necessary that specifications be subject to change without notice. All sales of the products of Astec Mobile Screens are subject to the provisions of its standard warranty. Astec Mobile Screens does not warrant or represent that its product meet and federal, state, or local statutes, codes, ordinances, rules, standards or other regulations, including OSHA and MSHA, covering safety, pollution, electrical wiring, etc. Compliance with these statutes and regulations is the responsibility of the user and will be dependent upon the areas and the use to which the product is put by the user. In some photographs, guards may have been removed for illustrative purposes only. This equipment should not be operated without all guards attached in their normal position. Placement of guards and other safety equipment is often dependent upon the area and the use to which the product is put. A safety study should be made by the user of the application, and, if required additional guards, warning signs and other safety devices should be installed by the user, wherever appropriate before operating the products.