

# CRS6203V PORTABLE SCREEN PLANT



## STANDARD FEATURES

- ▶ \*LJ-TSV6203 variable slope triple shaft high g-force 3-deck screen
- ▶ \*Hydraulic raising module lifts screen up to 10° in 2.5° increments
- ▶ \*Screen suspension and low-maintenance screen stabilization system
- ▶ \*Screen accepts 4' and 5' (1219 and 1524 mm) panels
- ▶ \*Bottom deck deflector plates boost screen efficiency
- ▶ 25 hp (19 kW), 42" (1067 mm) wide overhead conveyor with dual hinge transition
- ▶ 10 hp (7.5 kW), 48" (1220 mm) wide underscreen fines conveyor, raises with screen in 2.5° increments
- ▶ Two 7.5 hp (5.5 kW), 30" (762 mm) wide, reversible top and center deck cross conveyors
- ▶ 7.5 hp, 24" (610 mm) wide, reversible bottom deck cross conveyor
- ▶ Cross conveyors discharge 44" (1117 mm) beyond frame
- ▶ All conveyor belts are 3-ply with vulcanized belt splices
- ▶ 4-section, 2-position blending system to mix second and bottom deck overs
- ▶ Under-frame mounted tandem axle spring suspension with spring-applied brakes
- ▶ Four hydraulic leveling jacks and two pinned telescopic support legs
- ▶ Enclosed gas powered plant hydraulic unit for setting screen slope, conveyor position, and jacks
- ▶ Many easy maintenance features including conveniently located grease banks, cartridge style cross belt flashing and low-maintenance motion dampers
- ▶ Martin style conveyor belt wipers
- ▶ Side mounted lockable storage box
- ▶ Service platforms and guard rails around three sides of screen with telescoping access ladder

\*Patent Pending

## OPTIONAL EQUIPMENT

- ▶ Patent pending fines reject chute system
- ▶ Electrical switchgear panel with push button controls or remote with tether
- ▶ Extra off plant motor starters and controls
- ▶ 30 hp (22 kW) overhead conveyor motor in place of 25 hp (19 kW)
- ▶ 100' (30.5 m) power cables with cable wraps for stowage
- ▶ Power cable quick disconnects
- ▶ 12V or 24V plant hydraulic unit
- ▶ Heavy-duty hydraulic run-on jacks
- ▶ Belt scale on feed conveyor
- ▶ Portable screen lube filter unit
- ▶ Dust suppression system
- ▶ Oversize 315 80R x 22.5 tires

# SPECIFICATIONS

# Terex® Minerals Processing Systems Cedarapids CRS6203V Portable Screen Plant

## Transport

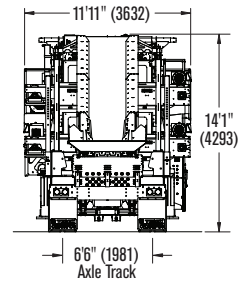
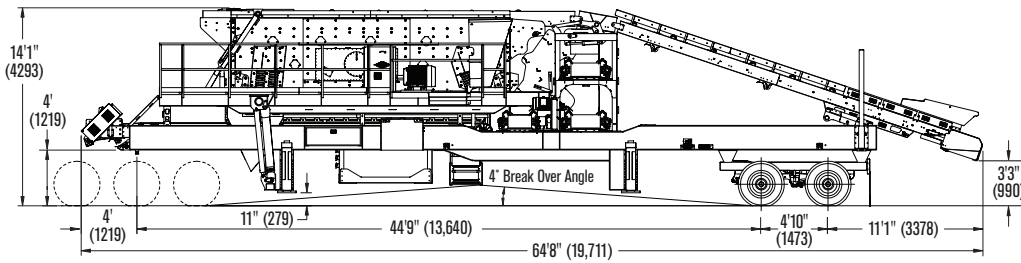

## Operational

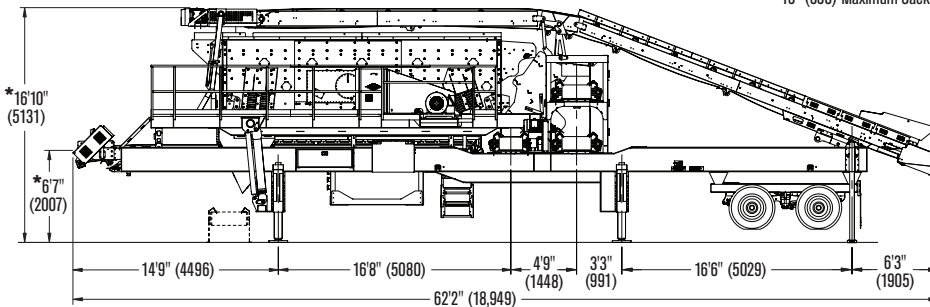
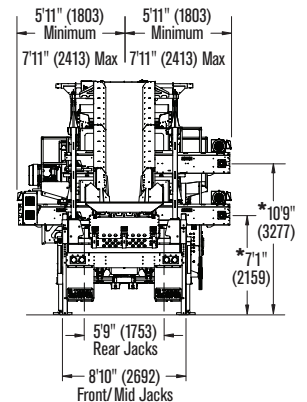
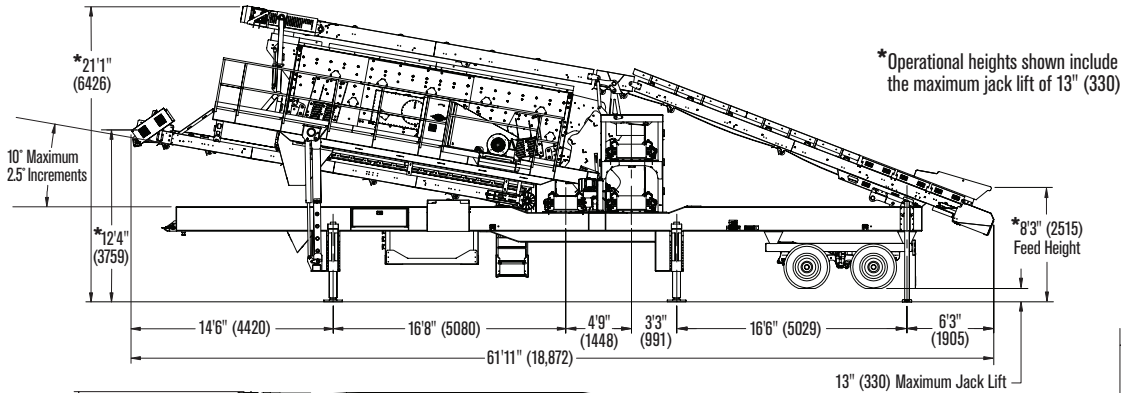

## SPECIFICATIONS

LJ-TSV6203 screen .....	6' x 20' (1829 x 6096 mm)
Overhead conveyor .....	42" (1067 mm)
Underscreen fines conveyor .....	48" (1220 mm)
Reversible cross conveyor .....	24" (610 mm)
Reversible cross conveyors (2) .....	30" (762 mm)
Tires .....	Eight 295 75R x 22.5

### Horsepower

LJ-TSV6203 screen.....	40 hp (30 kW)
Overhead conveyor.....	25 hp (19 kW)
Underscreen fines conveyor .....	10 hp (7.4 kW)
Reversible cross conveyors (3) .....	7.5 hp (5.6 kW)

### Estimated weight (fully optional)

Rear axle.....	37,000 lbs (16,785 kg)
Kingpin .....	35,000 lbs (15,875 kg)
Total .....	72,000 lbs (32,660 kg)

[www.terexmps.com](http://www.terexmps.com)

Effective Date: June 2012. Product specifications and prices are subject to change without notice or obligation. The photographs and/or drawings in this document are for illustrative purposes only. Refer to the appropriate Operator's Manual for instructions on the proper use of this equipment. Failure to follow the appropriate Operator's Manual when using our equipment or to otherwise act irresponsibly may result in serious injury or death. The only warranty applicable to our equipment is the standard written warranty applicable to the particular product and sale and Terex makes no other warranty, express or implied. Products and services listed may be trademarks, service marks or trade-names of Terex Corporation and/or its subsidiaries in the USA and other countries. All rights are reserved. Terex is a registered trademark of Terex Corporation in the USA and many other countries. © 2012 Terex Corporation.

Terex® Minerals Processing Systems, 909 17th Street NE, Cedar Rapids, IA 52402 USA  
Tel +1 319 363 3511 Fax +1 319 399 4871 [www.terexmps.com](http://www.terexmps.com)

Form 25825 (6/12)



**WORKS FOR YOU.**