

KOMATSU®

D375A-6

NET HORSEPOWER
455 kW **610 HP** @ 1800 rpm

OPERATING WEIGHT
71640 kg **157,940 lb**

D
375A

CRAWLER DOZER



Photos may include optional equipment.

WALK-AROUND

SAA6D170E-5 turbocharged aftercooled diesel engine provides a net output of 455 kW **610 HP** with excellent productivity. This machine is EPA Tier 3 and EU stage 3A emissions certified (p.6).

Preventative maintenance

- Centralized Service Station
- Enclosed Hydraulic Piping
- Modular Power Train Design
- Oil Pressure Checking Ports (p.9)
- Multi-Monitor with Self Diagnostic Function
- KOMTRAX Plus

Automatic transmission with lockup torque converter increases speed and power to improve fuel consumption and productivity (p.6).

High efficiency blade

provides a new blade profile to maximize productivity. Semi-U dozer 18.5 m³ **24.2 yd³**/
Full-U dozer 22.0 m³ **28.8 yd³**

Simple hull frame

and monocoque track frame with pivot shaft for greater reliability.

The **Dual tilt dozer** increases productivity while reducing operator effort (p.6).

Track link design

reduces maintenance cost by making turning pins easier, with improved pin reuse (p.9).

Komatsu-integrated design

for the best value, reliability, and versatility. Hydraulics, power train, frame, and all other major components are engineered by Komatsu. You get a machine with components designed to work and wear together as a system for higher production, greater reliability, and more versatility.

Hydraulically driven radiator cooling fan

controlled automatically, reduces fuel consumption and operating noise levels (p.6).



Low-drive, long-track, eight roller undercarriage provides outstanding grading ability and stability.

Track shoe slip control system

reduces operator fatigue (p.7).

Hexagonal designed cab includes:

- Spacious interior
- Comfortable ride with cab damper mounting
- Excellent visibility
- High capacity air conditioning system
- Palm Command Control System (PCCS) joystick controls
- Pressurized cab
- Adjustable armrests
- Travel control console integrated with operator seat (p.4)

Large TFT LCD monitor

- Easy-to-see and use large 7" multi-color monitor (p.8)
- Can be displayed in 10 languages for global support
- Full diagnostic capability

TFT : Thin Film Transistor

LCD : Liquid Crystal Display

NET HORSEPOWER
455 kW 610 HP @ 1800 rpm

OPERATING WEIGHT
71640 kg 157,940 lb

BLADE CAPACITY
Semi-U: 18.5 m³ 24.2 yd³
Full-U: 22.0 m³ 28.8 yd³

Electronic Controlled Modulation Valve (ECMV)

controlled steering clutch/brake system facilitates smooth and shockless steering operation (p.5).

Palm Command Control System (PCCS)

- Electronic controlled PCCS travel control
- Hydraulic controlled PCCS blade/ripper control
- Fuel control dial
- Automatic/manual gearshift selectable mode
- Gearshift pattern preset function
- ECMV controlled transmission (p.5)

Rear attachments (optional)

- Variable giant ripper
- Multi-shank ripper
- Counterweight

KOMTRAX Plus

provides efficient monitoring of machine conditions for maximum productivity (p.9).



Photos may include optional equipment.

K-Bogie undercarriage system

improves traction, component durability, and operator comfort (p.6).

Extra-low machine profile

provides excellent machine balance and low center of gravity.

CONTROL FEATURES

Komatsu's ergonomically designed control system "PCCS" creates an operating environment with "complete operator control."

Human-Machine Interface

Palm Command Electronic Controlled Travel Control Joystick

Ergonomically designed palm command travel joystick provides the operator with a relaxed posture and superb control improving operator comfort. Transmission gear shifting is simply carried out with thumb push buttons.

Left-hand Joystick

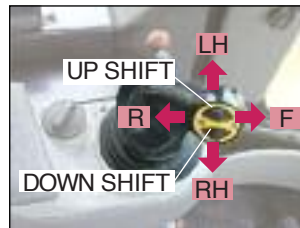

Fully Adjustable Air Suspension Seat and Travel Control Console

For improved rear visibility during the return portion of the cycle, the operator can adjust the seat 15° to the right. The transmission and steering controls move with the seat for optimum operator comfort. The travel control console is adjustable fore, aft, and for height. The armrest is independently adjustable up and down, providing optimum operation posture for all operators. The operator seat is also tiltable for facilitating downhill dozing.

Facing Front



When Turned 15°



Palm Command PPC Controlled Blade Control Joystick

The blade control joystick uses the Proportional Pressure Control (PPC) valve and joystick, similar to the travel control joystick. PPC control combined with the highly reliable Komatsu hydraulic system enables superb control. Dual tilt and pitch operation are enabled by pressing a switch with the thumb.

Blade and Ripper Control Joysticks



Fuel Control Dial

Engine RPM is controlled by electric signals, providing ease of operation and eliminating maintenance of linkage and joints. RPM is controlled by simply turning a dial.

Height Adjustable Blade Control Armrest

Blade control armrest is height adjustable without any tools, in three stages, providing the operator with firm arm support and ideal comfort.

Position Adjustable Ripper Control Lever

Ripper control lever is adjustable, providing optimum operator posture during all types of ripping operations.

Outline of Electronic Control System

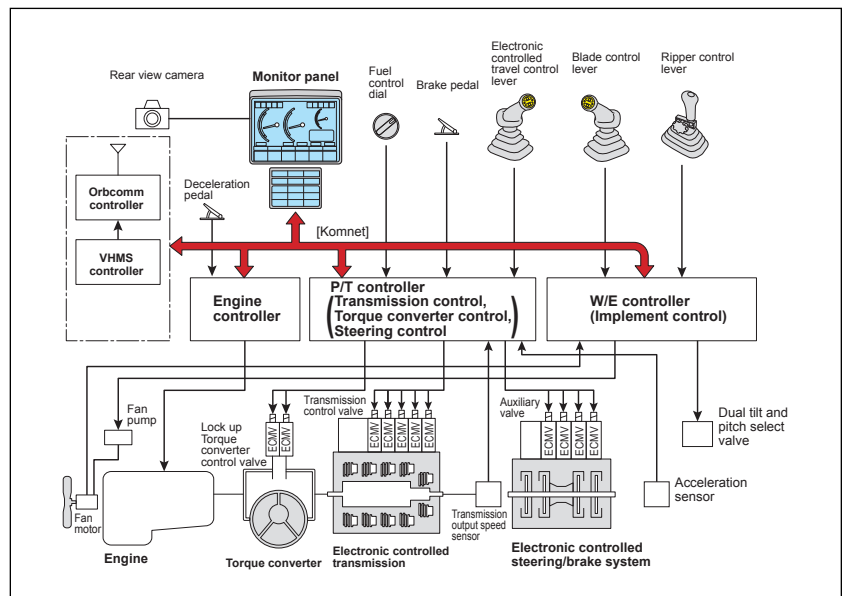

Power Train Electronic Control System

Smooth Operation

The D375A-6 utilizes a highly efficient power train electronic control system. The controller registers the amount of operator control (movements of lever and operation of switches) along with machine condition signals from each sensor to accurately calculate the control of the torque converter, transmission, steering clutches and brakes for optimized machine operation. The ease of operation and productivity of the new D375A-6 is greatly improved through these new features.

Electronic Controlled Modulation Valve (ECMV) Transmission

The controller automatically adjusts each clutch engagement depending on travel conditions such as gear speed, RPM and shifting pattern. This provides shockless and smooth clutch engagement, improved component reliability, extended component life, and operator ride comfort.

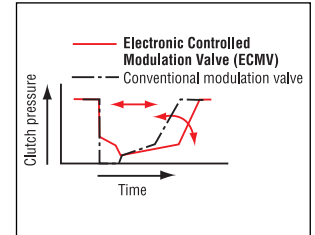

Electronic Controlled Modulation Valve (ECMV) Steering Clutches/Brakes

Sensors monitor machine operating conditions and electronically control the steering clutches and brakes. Monitoring application parameters such as incline angle of slope and degree of load provides smooth and easy operation by reducing counter-steering on downhill travel, etc.

Effect of ECMV Steering Clutches/Brake Control

When dozing and turning, ECMV automatically controls stroke ratio of steering clutches and brakes depending on degree of load, enabling smooth dozing and turning.

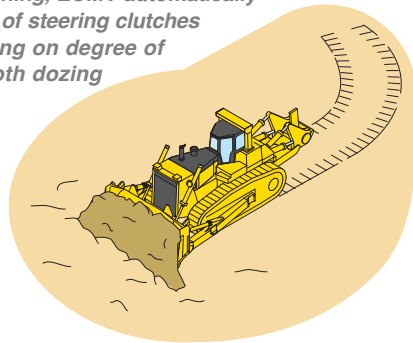

When dozing downhill, ECMV automatically controls steering clutches and brakes depending on incline of machine or degree of load, reducing counter-steering and producing smooth dozing operation.

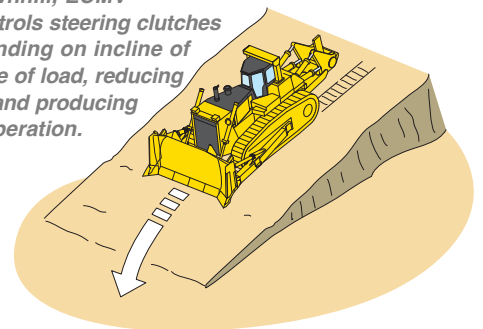

Preset Travel Speed Selection Function

Preset travel speed enables the operator to select fore and aft travel speeds among four preset patterns. When the gearshift pattern is set to either <F1-R1>, <F1-R2>, <F2-R2> or <F2-R3L>, in automatic gearshift mode, the gear is automatically shifted. This function reduces gear shifting time during repeated round-trip operations.

	Automatic gearshift mode	Manual gearshift mode	Shoe slip control mode
	F1-R1 MODE Press DOWN switch ↑ Press UP switch	F1-R1 MODE Press DOWN switch ↑ Press UP switch	F1-R1 MODE Press DOWN switch ↑ Press UP switch
	F1-R2 MODE Press DOWN switch ↑ Press UP switch	F1-R2 MODE Press DOWN switch ↑ Press UP switch	F1-R2 MODE
	F2-R2 MODE Press DOWN switch ↑ Press UP switch	F2-R2 MODE	
	F2-R3L MODE		

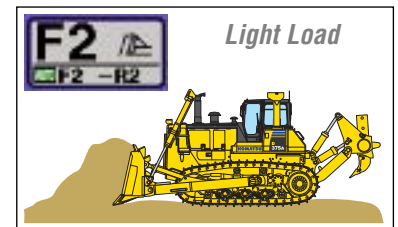
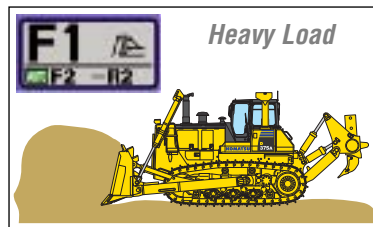

Auto Downshift Function

The controller monitors engine speed and travel speed. When load is applied and machine travel speed is reduced, the transmission automatically downshifts to the optimum gear speed to provide high fuel efficiency. This function provides comfortable operation and high productivity without manual downshifting.

Actuated on Heavy Load or Steep Slope

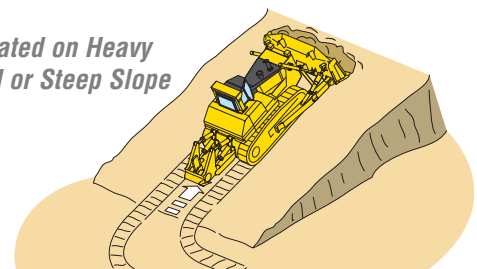

PRODUCTIVITY FEATURES



Komatsu's "ecot3" engines are designed to deliver optimum performance under the toughest of conditions, while meeting the most stringent

environmental regulations. This engine is EPA Tier 3, EU Stage 3A and Japan emissions certified; "ecot3" - ecology and economy combine with Komatsu technology to create a high performance engine without sacrificing power or productivity.

Engine

The Komatsu SAA6D170E-5 engine delivers a net output of 455 kW **610 HP** at 1800 rpm. The fuel-efficient Komatsu engine, together with the heavy machine weight, make the D375A-6 a superior crawler dozer in both ripping and dozing production. The engine is EPA Tier 3 and EU stage 3A emissions certified, and features direct fuel injection, turbocharger, air-to-air aftercooler and cooled EGR system to maximize fuel efficiency. To minimize noise and vibration, the engine is mounted to the main frame with rubber cushions.

Hydraulically Driven Radiator Cooling Fan

Fan rotation is automatically controlled depending on coolant and hydraulic oil temperatures, saving fuel and providing increased productivity with a quiet operating environment.

Automatic Torque Converter Lockup System

For greater efficiency during long pushes, the lockup mode allows the system to automatically engage the torque converter lockup clutch. Locking up the torque converter transmits all the engine power directly to the transmission, increasing ground speed and thus achieving efficiencies equal to a direct drive. The results of this efficient use of engine power are less fuel consumption and faster cycle times.

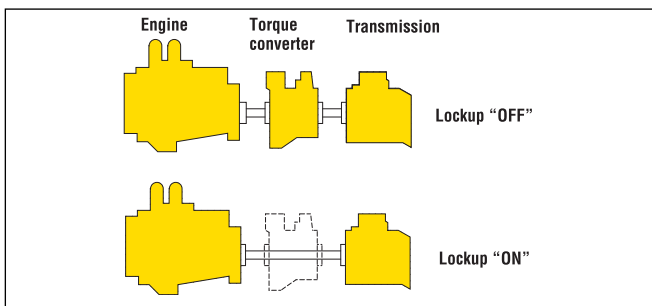

K-Bogie Undercarriage System

K-Bogies with front and rear single bogies are utilized to increase the length of track on ground improving machine stability and leveling performance. An oscillating idler and increased sprocket lead angle improve riding comfort when traveling over rough terrain. K-Bogies oscillate with two fulcrums assuring a large amount of track roller vertical travel. Impact load to undercarriage components is minimized and durability of components is improved since track rollers are always in contact with track links. Track rollers follow track link movement to extend the undercarriage life. Excellent riding comfort is provided due to less vibration and shock when traveling over rough terrain.

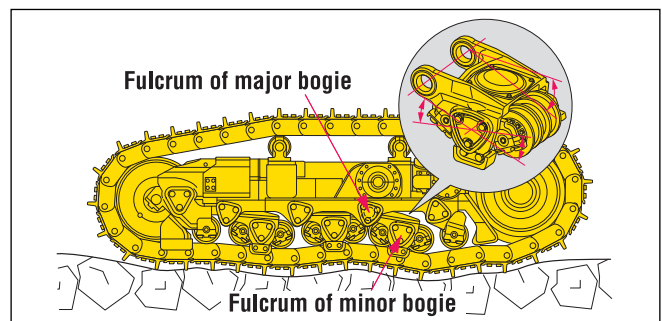

High Efficiency Blade

Capacities of 18.5 m³ **24.2 yd³** (Semi-U dozer) and 22.0 m³ **28.8 yd³** (U dozer) yield outstanding production. High-tensile-strength steel comprising the front and sides of the blade increase durability. A new blade profile features high load hauling efficiency to maximize productivity. The blade section profile has been changed to equal that of the next class size dozer and the height of the blade shoulder has been increased to reduce spillage. This increases the amount of hold soil the blade is capable of carrying. Improved end bits provide better penetration and extended wear life.

Dual Tilt Dozer

The dual tilt dozer increases productivity while reducing operator effort. Optimum blade cutting angle for all types of materials and grades can be selected on-the-go for increased load and production. Digging, hauling, and dumping are smooth and easy with less operator fatigue. Dozer tilt angle and tilt speed are twice that of a conventional single tilt system.

Rippers

The variable giant ripper is a parallelogram single shank ripper ideal for ripping tough material. The ripping angle is variable, and the depth is adjustable in three stages by a hydraulically controlled pin puller. The variable giant ripper features a long sprocket center-to-ripper point distance, making ripping operation easy and effective while maintaining high penetration force. The multi-shank ripper is a hydraulically controlled parallelogram ripper with three shanks



Automatic/Manual Gearshift and Shoe Slip Control

Automatic or manual gearshift modes can be easily selected to suit the work at hand by simply pressing the switch on the multi-monitor. (The mode can be selected when the travel control joystick is at NEUTRAL.)

Automatic gearshift mode

The mode for general dozing. When a load is applied, the gear automatically shifts down, and when the load is off, it automatically shifts up to a set maximum gear speed. This mode economizes both fuel and production where the torque converter lockup mechanism is actuated according to load, automatically selecting the optimum gear speed.

Manual gearshift mode

The mode for dozing and ripping rough ground. When loaded, the gear automatically shifts down, but does not shift up when the load is off.

Working Mode

This mode can be set to either “P mode” for maximum production (power) or “E mode” for energy saving operation (economy). Combined with the automatic gearshift mode or manual gearshift mode, the working mode allows the operator to select the optimum machine operating condition for the work at hand. (The mode can be switched during operation.)



Track Shoe Slip Control Mode

Eliminates the need for the operator to constantly control engine power output with the decelerator pedal while ripping substantially reducing operator fatigue. Maneuverability is improved because the operator is free to focus on the ripping application without having to monitor the track shoe slippage. Repair costs are significantly lowered and undercarriage life is extended with the reduction in track shoe slippage. The track shoe slip control system will contribute to lower fuel costs because the engine output is automatically controlled to optimum levels for operation.

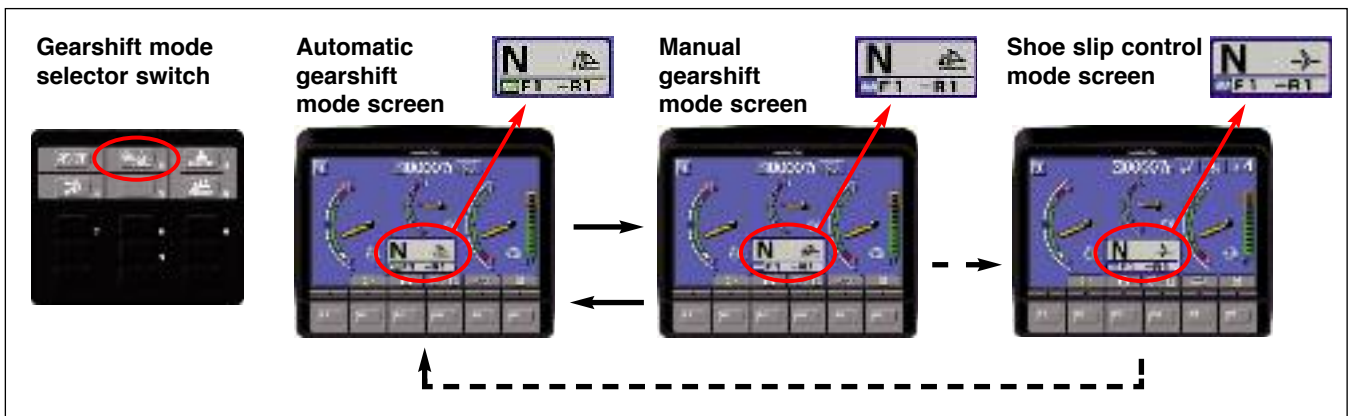

EASY MAINTENANCE

Preventative Maintenance

Preventative maintenance is the only way to ensure long service life from your equipment. That's why Komatsu designed the D375A-6 with conveniently located maintenance points to make necessary inspections and maintenance quick and easy.

Centralized Service Station

To ensure convenient maintenance, the transmission and torque converter oil filters are both arranged next to the power train oil level gauge.

Multi-Monitor with Self-Diagnostic Function

Various meters, gauges, and warning functions are centrally arranged on the multi-monitor. This offers ease of start-up inspection and promptly warns the operator with a lamp and buzzer if any abnormalities should occur. In addition, countermeasures are indicated in 4-stage codes to help prevent the machine from incurring major problems. Replacement times for oil and filters are also indicated.

Maintenance warning screen



Abnormality warning screen



Maintenance List screen for replacement time display

Gull-Wing Engine Side Covers

Dual insulated gull-wing engine side covers facilitate engine maintenance and filter replacement. Side covers are thick two-piece structures with bolt-on latches to improve durability and repairability.

Oil Pressure Checking Ports

Pressure checking ports for power train components are centralized to promote quick and simple diagnosis.

Enlarged Engine Compartment

Engine compartment space is enlarged by increased engine hood height, facilitating maintenance of the engine and related equipment. Solid engine hood prevents dust and rain from entering and helps keep the engine clean.

KOMTRAX Plus

As part of a complete service and support program, Komatsu equips every mining and quarry sized machine with KOMTRAX Plus. By using a satellite-based communication system, KOMTRAX Plus offers a new vision of monitoring your valuable assets by providing insight to critical operating metrics and information that can be used to increase availability, lower owning and operating costs and maximize fuel efficiency.

The KOMTRAX Plus information available on MyKomatsu.com allows service personnel and asset owners to review cautions, operational data, fuel consumption, payloads and key component measurements provided in forms of trends. With KOMTRAX Plus, knowledge becomes the power to fuel your productivity.



Low Maintenance Costs

Track Link with Wedge Ring

New D375A-6 track links feature reduced press-fit force and a wedge ring. Conventional track pins are retained only with a large press-fit force. (The new track link divides pin forces between the wedge ring and press-fit force.) This enables easier service with reduced pin damage when turning pins and bushings. The result is improved undercarriage life and reduced maintenance cost through reduced wear, greater pin reusability, and reduced maintenance man-hours.

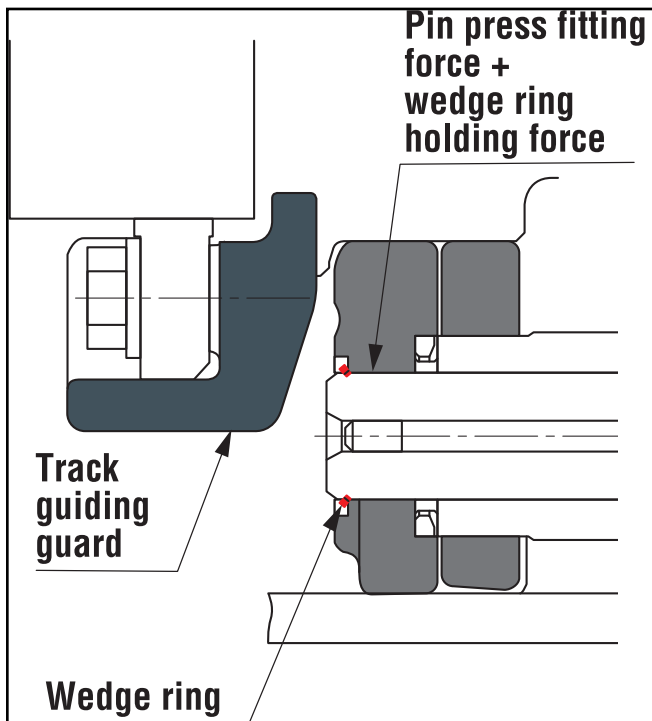

Highly Reliable Electric Circuits

The electrical circuit reliability is increased by utilizing dust, vibration and corrosion resistant "DT connectors". The reinforced electrical wiring harnesses include circuit breakers and are covered with a heat-resistant material to increase mechanical strength, provide longer life, and protect the system from damage.

Flat Face O-ring Seals

Flat face O-ring seals are used to securely seal all hydraulic hose connections.

Enclosed Hydraulic Piping

Hydraulic piping for the blade tilt cylinder is completely housed in the push arm protecting it from damage.

Modular Power Train Design

Power train components are sealed in a modular design that allows the components to be removed and replaced without oil spillage, making servicing work clean, smooth, and easy.

Maintenance-Free Disc Brakes

Wet disc brakes are adjustment free and provide excellent service life.

WORKING ENVIRONMENT



Hexagonal Pressurized Cab

The cab's hexagonal design and large tinted glass windows provide excellent front, side and rear visibility. Air filters and a higher internal air pressure combine to help prevent dust from entering the cab.

Fresh Air Intake from Rear of Engine Hood

The air conditioner air intake port is located at the rear of the engine hood where there is minimal dust. The cleaning interval of the filter is greatly extended, and use of a new structure filter element facilitates cleaning and replacement.

Large Multi-lingual LCD Color Monitor

A new large user-friendly color monitor enables accurate and smooth work. Improved screen visibility is achieved by the use of a Thin Film Transistor (TFT) liquid crystal display that can easily be read at various angles and lighting conditions. Simple and easy to operate switches. Function keys facilitate multi-function operations. Capable of displaying data in 10 languages to globally support operators around the world.



Comfortable Ride with Cab Damper Mounting and K-Bogie Undercarriage

The D375A-6's cab mount uses a cab damper mounting which provides excellent shock and vibration absorption capacity with its long stroke. The cab damper mounting, combined with the K-bogie undercarriage, softens shocks and vibrations while traveling over adverse conditions. This is otherwise impossible to absorb with conventional cab mounting methods. The soft spring cab damper isolates the cab from the machine body, suppressing vibrations and providing a quiet, comfortable operating environment.

Cab Damper Mounting

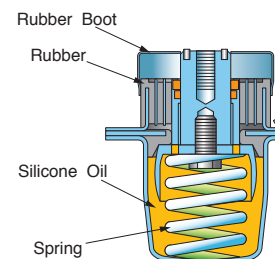

Simple, Durable Hydraulic System

Utilizing a variable piston pump and Closed-center Load Sensing System (CLSS), the hydraulic system has been greatly simplified. The variable piston pump successfully applies hydraulic power as needed to the blade and ripper. The amount of serviceable parts and opportunity for additional maintenance or failures are greatly reduced.

OPTIONAL SPECIFICATIONS

High Mounted Headlights

Illuminate the places in front of the machine more effectively. Use of optional HID lamps further improves visibility.



Rear View Camera

Improves rear visibility and is easily viewable on the multi-monitor. Machine is capable of mounting 3 external cameras.



Rear view camera

Manual Engine Shutdown Switches

In case of urgent need to stop the engine, two shutdown switches are provided, in the cab and at the right rear of the machine.



Switch location (inside the cab)



Switch location (at the rear)

Uninterrupted Power Source

Uninterrupted power source allows for 2-way radio communication at any time. (Interior lights can be turned on with the starting switch at OFF position.)

Access Lights

Access lights are installed at the front (2, right and left) and (1) at the rear of the machine.



Work Light for the Engine Compartment

A work light is installed inside the engine hood (left side) to facilitate night-time inspection and maintenance.



Provision for Platforms

Provision for platforms eliminates the need to modify the machine for future installation of platforms.

Platforms with Handrails and Foot Barriers

Optional platforms can be ordered to give access to the side faces and the rear of the machine.

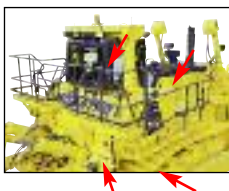

Isolator Box

Battery and starting motor isolators are housed in the isolator box on the left side of the machine to facilitate cut-off of the battery circuit for maintenance of the machine. Jump-start connectors are also provided in the box in case of power failure.

A : Starter isolator

B : Jump start receptacle

C : Battery isolator

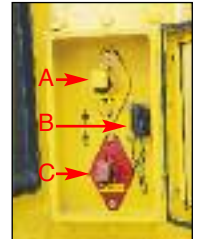

Canister-type Breathers

Canister-type breathers are remotely arranged inside the left exterior cover to facilitate check and cleaning of the breather of each component.

A : Power train case B : Flywheel housing

C : Damper case

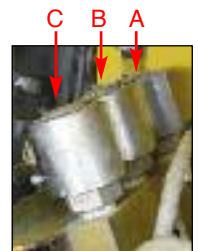

Maintenance Service Center

Couplings (made by Wiggins) installed at the rear left of the machine enable quick drain and change of oil and coolant. The Fast Fuel fill (also by Wiggins) enables refueling from ground level. The service center eliminates the need to get on/off the machine and to remove/install covers to perform fluid maintenance.

A : Engine oil

B : Radiator coolant

C : Transmission oil D : Hydraulic oil

E : Fast Fuel Fill



Concentrated Sampling Points

Concentrated sampling points are remotely arranged in the tool box storage area to facilitate sampling of the oil and coolant from each component.

A : Engine oil

B : Radiator coolant

C : Transmission oil D : Hydraulic oil

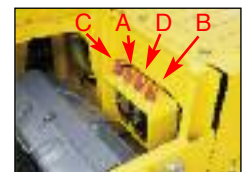

Centralized Grease Points for Blade Cylinder Yoke and Ripper Mount Pin

Centralized grease points enable lubrication of both blade and ripper from ground level.



SPECIFICATIONS



ENGINE

ModelKomatsu SAA6D170E-5*
 Type 4-cycle, water-cooled, direct injection
 Aspiration Turbocharged, air-to-air aftercooled, cooled EGR
 Number of cylinders 6
 Bore x stroke 170 mm x 170 mm **6.69" x 6.69"**
 Piston displacement 23.15 ltr **1,413 in³**
 GovernorAll-speed and mid-range, electronic
 Horsepower
 SAE J1995Gross 474 kW **636 HP**
 ISO 9249 / SAE J1349Net 455 kW **610 HP**
 Hydraulic fan at maximum speedNet 433 kW **580 HP**
 Rated rpm 1800 rpm
 Fan drive typeHydraulic
 Lubrication system
 MethodGear pump, force lubrication
 FilterFull-flow

* EPA Tier 3 and EU Stage 3A emissions certified.



TORQFLOW TRANSMISSION

Komatsu TORQFLOW transmission consists of a water-cooled, 3-element, 1-stage, 1-phase torque converter with lockup clutch and a planetary gear, multiple-disc clutch transmission which is hydraulically actuated and force-lubricated for optimum heat dissipation. Gearshift lock lever and neutral safety switch help prevent accidental starts.

Gear	Forward		Reverse	
	km/h	mph	km/h	mph
1st	3.5	2.2	4.6	2.9
2nd	6.8	4.2	8.9	5.5
3rd L	8.0	5.0	9.7	6.0
3rd	11.8	7.3	15.8	9.8

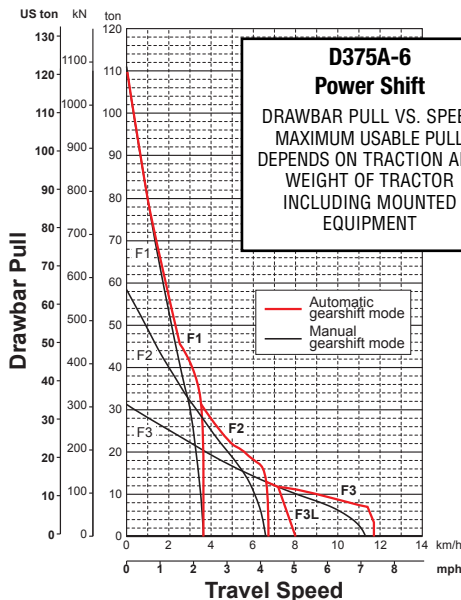

FINAL DRIVES

Double-reduction final drive of spur and planetary gear sets to increase tractive effort and reduce gear tooth stresses for long final drive life. Segmented sprocket teeth are bolt-on for easy replacement.



STEERING SYSTEM

PCCS, joystick controlled, wet multiple-disc steering clutches are spring-loaded and hydraulically released. Wet multiple-disc, pedal/lever controlled steering brakes are spring-actuated hydraulically released and require no adjustment. Steering clutches and brakes are interconnected for easy, responsive steering.

Minimum turning radius 4.2 m **13'9"**



UNDERCARRIAGE

SuspensionOscillating equalizer bar and pivot shaft
 Track roller frameCylindrical, high-tensile-strength steel construction

Rollers and idlersLubricated track rollers

K-Bogie undercarriage

Lubricated track rollers are resiliently mounted to the track frame with a bogie suspension system whose oscillating motion is cushioned by rubber pads.

Extreme service track shoes

Lubricated tracks. Unique seals prevent entry of foreign abrasives into pin to bushing clearances to provide extended service life. Track tension is easily adjusted with grease gun.

Number of shoes (each side) 41

Grouser height:

Single grouser 93 mm **3.7"**

Shoe width (standard) 610 mm **24"**

Ground contact area 48560 cm² **7,527 in²**

Ground pressure (tractor) 108 kPa 1.10 kg/cm² **15.6 psi**

Number of track rollers 8

Number of carrier rollers 2

Extreme service shoes	Additional weight	Ground contact area	Ground** pressure
610 mm 24"	0 kg 0 lb	48560 cm ² 7,527 in²	145 kPa 1.48 kgf/cm ² 21.0 psi
710 mm 28"	680 kg 1,500 lb	56520 cm ² 8,760 in²	126 kPa 1.28 kgf/cm ² 18.2 psi
810 mm 32"	1360 kg 3,000 lb	64480 cm ² 9,990 in²	111 kPa 1.13 kgf/cm ² 16.0 psi

** Ground pressure based on tractor, Semi-U tilt dozer, giant ripper, cab, ROPS, operator, standard equipment, rated capacity of lubricant, coolant, and full fuel tank.



COOLANT AND LUBRICANT CAPACITY (REFILL)

Fuel tank 1200 ltr **317.0 U.S. gal**

Coolant 120 ltr **31.7 U.S. gal**

Engine 86 ltr **22.7 U.S. gal**

Torque converter, transmission,

bevel gear, and steering system 150 ltr **39.6 U.S. gal**

Final drive (each side) 65 ltr **17.1 U.S. gal**



DIMENSIONS

SEMI-U DOZER WITH GIANT RIPPER

A	2500 mm	8'2"
B	4695 mm	15'5"
C	4265 mm	14'0"
D	2265 mm	7'5"
E	3980 mm	13'1"
F	10485 mm	34'5"
G	3460 mm	11'4"
H	1485 mm	4'10"
I	1100 mm	3'7"
J	4285 mm	14'1"

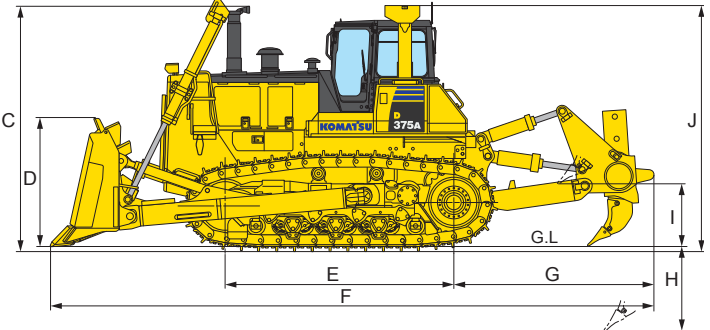
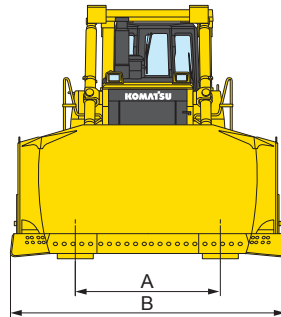

Ground Clearance: 610 mm 2'0"



OPERATING WEIGHT

Tractor weight 53200 kg **117,290 lb**
Including rated capacity of lubricant, coolant, full fuel tank, operator, and standard equipment.

Operating weight 71640 kg **157,940 lb**
Including Semi-U tilt dozer, giant ripper, cab, ROPS, operator, standard equipment, rated capacity of lubricant, coolant, and full fuel tank.

Ground pressure 145 kPa 1.48 kg/cm² **21.0 psi**



HYDRAULIC SYSTEM

Hydraulic control unit:
Closed-center load sensing system (CLSS) designed for precise and responsive control, and for efficient simultaneous operation.

Hydraulic control unit:
All spool control valves externally mounted beside the hydraulic tank.
Variable piston pump with capacity (discharge flow) of 366 ltr/min **96.7 U.S. gal/min** for implement at rated engine rpm.
Relief valve setting. . . for implement 27.5 MPa 280 kg/cm² **3,980 psi**

Control valves:
Spool control valves for Semi-U tilt dozer and Full-U tilt dozer.
Positions: Blade lift Raise, hold, lower, and float
Blade tilt Right, hold, and left

Additional control valve required for variable digging angle multi-shank ripper and giant ripper.
Positions: Ripper lift Raise, hold, and lower
Ripper tilt Increase, hold, and decrease

Hydraulic cylinders Double-acting, piston

	Number of cylinders	Bore
Blade lift	2	140 mm 5.5"
Blade tilt	1	180 mm 7.1"
Ripper lift	2	200 mm 7.9"
Ripper tilt	2	180 mm 7.1"

Hydraulic oil capacity (refill):
Semi-U dozer or U dozer 130 ltr **34.4 U.S. gal**
Ripper equipment (additional volume):
Giant ripper (variable) 45 ltr **11.9 U.S. gal**
Multi-shank ripper (variable) 45 ltr **11.9 U.S. gal**



DOZER EQUIPMENT

Blade capacities are based on the SAE recommended practice J1265.

	Overall length with dozer	Blade capacity	Blade length x height (with spill guard height)	Maximum lift above ground	Maximum drop below ground	Maximum tilt adjustment	Weight		Ground Pressure*
							Dozer equipment	Hydraulic oil	
Strengthened Dual tilt Semi-U dozer	7780 mm 25'6"	18.5 m ³ 24.2 yd³	4695 mm x 2265 mm 15'5" x 7'5"	1690 mm 5'7"	735 mm 2'5"	1185 mm 3'11"	11570 kg 25,510 lb	50 kg 110 lb	146 kPa 1.49 kgf/cm² 21.2 psi
Strengthened dual tilt U dozer with spill guard	8140 mm 26'8"	22.0 m ³ 28.8 yd³	5140 mm x 2265 mm (2525 mm) 16'10" x 7'5" (8'3")	1690 mm 5'7"	735 mm 2'5"	1300 mm 4'3"	12600 kg 27,780 lb	50 kg 110 lb	148 kPa 1.51 kgf/cm² 21.4 psi

*Ground pressure shows tractor with cab, ROPS, variable giant ripper, standard equipment and applicable blade.



STANDARD EQUIPMENT FOR BASE MACHINE

- Accessory sockets, 2x12V
- Air conditioner with heater and defroster
- Alternator, 90 ampere/24V
- Back-up alarm
- Batteries, 2X12V, 200 Ah
- Blower cooling fan
- Car stereo
- Decelerator pedal
- Dry-type air cleaner with dust evacuator and dust indicator
- Dual tilt dozer
- Eight-roller track frames
- Engine oil level sensor
- Engine prelube
- Final drive case wear guard
- Hinged front mask
- Hinged underguard with front pull hook
- Hydraulics for ripper
- Hydraulic track adjusters
- K-Bogie Undercarriage System
- KOMTRAX Plus
- Lockup torque converter

- Lunch box holder
- Mirror, rear view
- Monitor, large multi-color TFT LCD with self-diagnostic function
- Muffler with rain cap
- PCCS palm lever steering control
- Perforated side covers
- Radiator reserve tank
- ROPS
- Seat belt, 78 mm, 3"
- Seat, air suspension, fabric, high back, fully adjustable
- Shoes, 610 mm 24" extreme service, single-grouser
- Segmented sprockets
- Spill guard for Full-U dozer
- Starting motors, 2 x 7.5 kW/24V
- Steps, heavy-duty and handles
- Sun visor
- TORQFLOW transmission
- Track roller guards
- Track shoe slip control system

- Vandalism protection kit
- Warning horn
- Wet steering clutches

ROPS:*

Weight 700 kg **1,540 lb**

Roof dimensions:

Width 1980 mm **6'6"**

Height from

compartment floor 1872 mm **6'2"**

*Meets ISO 3471 and SAE J1040 APR88, ROPS standards

Steel cab:*

Weight 570 kg **1,260 lb**

Dimensions:

Length 1875 mm **6'2"**

Width 1740 mm **5'9"**

Height from compartment

floor to ceiling 1630 mm **5'4"**

*Meets ISO 3449 FOPS standard



OPTIONAL EQUIPMENT

- Counterweight
- Cushion push block
- Hitch
- Fast fuel fill
- HID work lights
- High mounted headlights
- Panel cover
- Pusher plate
- Rear view camera
- Spill guard for Semi-U dozer
- Shoes:
 - 710 mm **28"**
 - 810 mm **32"**

- Strengthened Semi-U blade
- Strengthened Full-U blade

Multi-shank ripper:

Hydraulically controlled parallelogram ripper with three shanks. Ripping angle is steplessly adjustable.

Weight (including hydraulic

control unit and oil) . . . 6800 kg **14,900 lb**

Beam length. 2910 mm **9'7"**

Maximum lift above ground . . 1135 mm **3'9"**

Maximum digging depth. . . . 1140 mm **3'9"**

Variable giant ripper:

Variable, parallelogram single-shank ripper ideal for ripping up tough material. Ripping angle is variable. Ripping depth is adjustable in three stages by a hydraulically controlled pin puller.

Weight (including hydraulic

control unit and oil) . . . 6200 kg **13,670 lb**

Beam length. 1453 mm **4'9"**

Maximum lift above ground . . 1100 mm **3'7"**

Maximum digging depth . . . 1485 mm **4'10"**

Note: ProVision High Precision GPS grade level system available from Modular Mining



OPTIONAL MINING SPECIFICATION PACKAGE

Must order all items in this group for Mining Specification Package:

- Additional front and rear work lights
- Batteries and starter isolator box
- Cab light uninterrupted power source
- Canister-type breathers
- Centralized grease points, ripper mount pin

- Centralized grease points, blade cylinder yoke
- Concentrated sampling points for oil and coolant
- Fast fuel fill
- High mounted headlights

- Maintenance service center for oil and coolant
- Manual engine stop switches
- Provision for platforms
- Rear view camera
- Work light for the engine compartment

May order individually in addition to Mining Specification Package:

- HID work lights
- Platforms with handrails and foot barriers right and left sides

AESS800-02

©2011 Komatsu America Corp.

Printed in USA

AD04(2.5M)OSP

04/11 (EV-1)

