

# KOMATSU®

## HD465-7

### With Tier 3 Engine

**GROSS HORSEPOWER**

551 kW 739 HP

**NET HORSEPOWER**

533 kW 715 HP

**MAXIMUM GVW**

99680 kg 219,760 lb

**HD**  
**465**

OFF-HIGHWAY TRUCK



Photo may include optional equipment.

# WALK-AROUND

## *Productivity Features*

- High performance Komatsu SAA6D170E-5 engine  
Net horsepower 533 kW **715 HP**
- Mode selection system  
(Variable horsepower at Economy mode)
- Automatic Idling Setting System (AISS)
- Automatic Retard Speed Control (ARSC)
- 7-speed, fully automatic K-ATOMiCS transmission
- Fully hydraulic controlled wet multiple-disc brakes and retarder; Retarder absorbing capacity (Continuous descent) 785 kW **1,052 HP**
- Long wheelbase and wide tread
- Large high strength body  
Heaped capacity 34.2 m<sup>3</sup> **44.7 yd<sup>3</sup>**
- Small turning radius 8.5 m **27'11"**

## *Environment Friendly*

- Komatsu SAA6D170E-5 engine is North American EPA Tier 3 and EU Stage 3A emission certified
- Low operation noise
- Lead-free radiator
- Brake cooling oil recovery tank

## *Reliability Features*

- Komatsu components
- Highly rigid frames
- Rigorous dump body design
- Reliable hydraulic system
- Flat face-to-face O-ring seals
- Sealed DT Connectors
- Antilock Brake System (ABS) (Option)
- Automatic Spin Regulator (ASR) (Option)
- Pedal-operated secondary brake



**GROSS HORSEPOWER**  
551 kW 739 HP @ 2000 rpm

**NET HORSEPOWER**  
533 kW 715 HP @ 2000 rpm

**MAXIMUM GVW**  
99680 kg 219,760 lb

### ***Operator Environment***

- Wide, spacious cab with excellent visibility
- Ergonomically designed cab
- Easy-to-see instrument panel
- Ideal driving position settings
- K-ATOMiCS with “Skip-Shift” function
- Hydropneumatic suspension
- Built-in ROPS/FOPS Level 2
- Viscous cab mounts
- Electric body dump control lever
- Electric operated LH window
- Supplementary steering and secondary brakes
- Three-mode hydropneumatic suspension (Automatic suspension) (Option)



### ***Easy Maintenance***

- Advanced monitoring system - on board diagnostics
- Wet multiple-disk brakes and fully hydraulic braking system
- Extended oil change interval
- Centralized arrangement of filters
- Flange type rim
- Electric circuit breaker
- Centralized greasing points
- KOMTRAX Plus with Payload Meter and ORBCOMM (Option)

Photo may include optional equipment.

## PRODUCTIVITY FEATURES

### Komatsu Technology



ecology & economy - technology 3

Komatsu's new "ecot3" engines are designed to deliver optimum performance under the toughest of conditions while meeting the latest environmental regulations. This engine is Tier 3 EPA, EU Stage 3A and Japan emissions certified. "ecot3" – ecology and economy combined with Komatsu technology to create a high performance engine without sacrificing power or productivity.

### High performance Komatsu SAA6D170E-5 engine

This engine delivers faster acceleration and higher travel speeds with high horsepower per ton. Advanced technology, such as Common Rail Injection system (CRI), air-to-air aftercooler, efficient turbo-charger, and heavy-duty cooled EGR enables the engine to be North American EPA Tier 3 and EU stage 3A emission certified. High torque at low speed, impressive acceleration, and low fuel consumption ensure maximum productivity.

### Mode selection system

The system allows selection of the appropriate mode between <Power mode > or <Economy mode> according to each working condition. The mode is easily selected with a switch in the operator's cab.

### Power mode

Great productivity can be attained by taking full advantage of high output power. It is appropriate for job sites where larger production uphill-hauling is required.

### Economy mode (variable horsepower)

The engine power automatically changes depending on loaded or unloaded conditions and always uses an optimum gear speed. It is appropriate for light work on flat ground.

### Automatic Idling Setting System (AISS)

This system facilitates quick engine warm-up and cab cooling/warming. When setting the system ON, engine idle speed is kept at 945 rpm when coolant temperature is 50°C 122°F or lower. Speed automatically returns to 725 rpm when coolant temperature reaches 50°C 122°F.



### 7-speed, fully automatic K-ATOMiCS transmission

The K-ATOMiCS (Komatsu Advanced Transmission with Optimum Modulation Control System) automatically selects the optimum gear according to vehicle speed, engine speed and the shift position you've chosen. This results in the best gear for any driving situation.



K-ATOMiCS  
(Komatsu Advanced Transmission with Optimum Modulation Control System)

### Automatic Retard Speed Control (ARSC)(Option)

ARSC allows the operator to simply set the downhill travel speed and go down slopes at a constant speed. As a result, the operator can concentrate on steering. The speed can be set at increments of 1 km/h 0.6 MPH per click (±5 km/h 3.1 MPH of maximum speed adjustment) to match the optimum speed for the slope. Also, since the retarder cooling oil temperature is always monitored, the speed is automatically lowered.

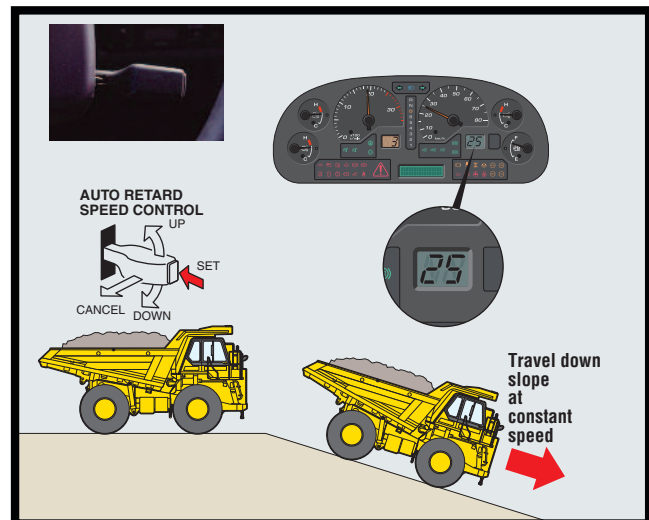

### Fully hydraulic controlled wet multiple-disc brakes and retarder

Wet multiple-disc brakes ensure highly reliable and stable brake performance. The large-capacity, continuously cooled, wet-multiple disc brakes also function as a highly responsive retarder which gives the operator greater confidence at higher speeds when travelling downhill.

- Retarder Absorbing Capacity (continuous descent): 785 kW  
**1,052 HP**
- Brake Surface Area (rear): 64230 cm<sup>2</sup>  
**9,956 in<sup>2</sup>**

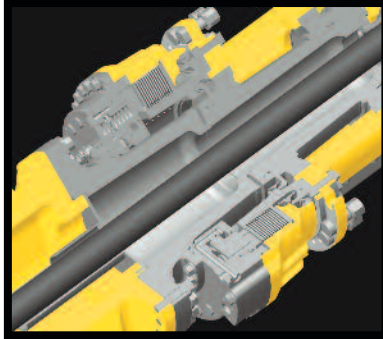

### Long wheelbase and wide tread

With an extra-long wheelbase, a wide tread and an exceptionally low center of gravity, the HD465-7 hauls the load at higher speed for more production, and delivers superior driving comfort over rough terrain.

### Large high strength body

A wide target area makes for easy loading with minimal soil spillage and more efficient hauling. The body is built of 130 kg/mm<sup>2</sup> **184,900 PSI** wear-resistant high-tensile steel with a Brinell hardness of 400. The V-shape design also increases structural strength and provides excellent load stability.

### Small turning radius

The MacPherson strut type front suspension has a special A-frame between each wheel and the main frame. The wider space created between the front wheels and the main frame increases the turning angle of the wheels. The larger this turning angle, the smaller the turning radius of the truck.

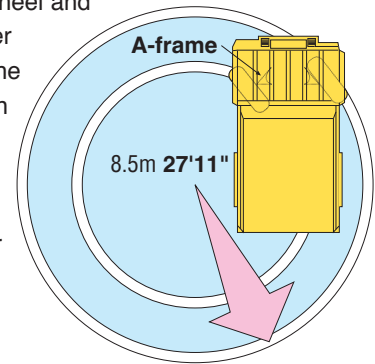

# OPERATOR ENVIRONMENT

## Wide, spacious cab with excellent visibility

Wide windows in the front, side and back, plus plenty of space in the richly upholstered interior, provide quiet, comfortable environment from which to see and control every aspect of operation. Front and side under view mirrors have also been added.

## Ergonomically designed cab

The ergonomically designed operator's compartment makes it very easy and comfortable for the operator to use all the controls. The result is more confident operation and greater productivity.

## Easy-to-see instrument panel

The instrument panel makes it easy to monitor critical machine functions. In addition, a caution light warns the operator of any problems that may occur. Problems are recorded in the monitor and indicated as service codes. This makes the machine user friendly and easy to service.

## Ideal driving position settings

The 5-way adjustable operator seat and the tilt-telescopic steering column create an optimum driving posture for increased driving comfort and more control over the machine's operations. The suspension seat dampens vibrations transmitted from the machine, which reduces operator fatigue and holds the operator securely to assure confident operation. 78 mm 3" width seat belt is provided as standard equipment.



## Hydropneumatic suspension for all terrains

The hydropneumatic suspension assures a comfortable ride even over rough terrain and ensures maximum productivity and operator confidence.

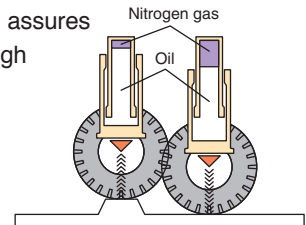

**K-ATOMiCS with “Skip-shift” function**

An electronically controlled valve is provided for each clutch pack in the transmission for independent clutch engagement/disengagement. It enables an ideal change in clutch modulation pressure and torque cut-off timing in response to travel conditions. This system and newly added “skip-shift” function ensure smooth shifting and responsive acceleration.

**“Skip-shift” function**

Optimum travel speed automatically selected in response to angle of ascent. This reduces the downshift frequency and provides smoother operation.

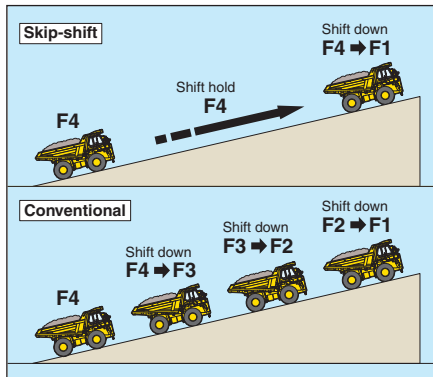

**Built-in ROPS/FOPS Level 2**

These structures conform to ISO3471 and SAE J1040 ROPS standards and ISO 3449 and SAE J231 FOPS Level 2 standards.



**Viscous cab mounts**

Viscous mounts reduce the noise transmitted to the cab and achieve a quiet 77 dB(A) noise level.

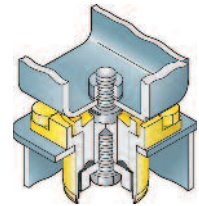

**Electric body dump control lever**

The low effort lever makes dumping easy. A positioning sensor is installed for dump body control which significantly reduces the shock made by the lowering of the dump body.



**Supplementary steering and secondary brakes**

Supplementary steering and secondary brakes are standard features.

Steering: ISO 5010, SAE J1511, SAE J53

Brakes: ISO 3450, SAE J1473



# RELIABILITY FEATURES

## Komatsu components

Komatsu manufactures the engine, torque converter, transmission, hydraulic units, and electrical parts on this dump truck. Komatsu dump trucks are manufactured with an integrated production system under a strict quality control system.

## High-rigidity frame

Cast-steel components are used in the main frame for high-stress areas where loads and shocks are most concentrated.



## Rigorous dump body design

The standard dump body is made of 130 kg/mm<sup>2</sup> **184,900 PSI** high-tensile-strength steel for excellent rigidity and reduced maintenance cost. The V-shape design also increases structural strength. The side and bottom plates of the dump section are reinforced with ribs for added strength.

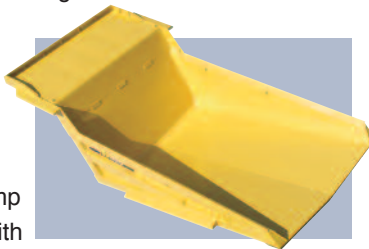

## Reliable hydraulic system

The oil cooler is installed in the radiator lower tank, improving the reliability of the hydraulic system during sudden temperature rises. In addition to the main filter, a 25-micron line filter is installed at the entrance to the transmission control valve. This system helps to prevent secondary faults.

## Flat face-to-face O-ring seals

Flat face-to-face O-ring seals are used to securely seal all hydraulic hose connections and to prevent oil leakage.

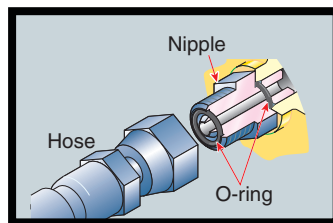

## Sealed DT connectors

Main harnesses and controller connectors are equipped with sealed DT connectors providing high reliability, water resistance, and dust resistance.



## Antilock braking system (ABS) (Option)

Using its outstanding electronics technology, Komatsu is the first in the industry to introduce ABS on construction machinery. This system prevents the tires from locking, thus minimizes skidding under slippery conditions while applying the service brake.

## Automatic spin regulator (ASR) (Option)

ASR automatically prevents the rear tires, on either side, from slipping on soft ground for optimal traction.

## Pedal-operated secondary brake

If there should be a failure in the foot brake, the parking brake and front disc brakes are activated as pedal operated secondary brake. In addition, when hydraulic pressure drops below the rated level, the parking brake is automatically actuated.



## Lead-free radiator

In addition to compliance with emission regulations, a lead-free aluminum core is utilized for the radiator to comply with global environmental requirements.

## Brake cooling oil recovery tank

To protect the environment, a tank is installed to recover brake cooling oil in the event of brake floating seal leakage.

## Protection functions supported by electronic control

Item	Function
<b>Downshift inhibitor</b>	Even if the driver downshifts accidentally, a speed appropriate to the current gear is automatically set, preventing over-runs.
<b>Over-run inhibitor</b>	When descending grades, if vehicle's speed surpasses maximum for current gear, rear brakes automatically operate, preventing over-runs.
<b>Reverse inhibitor</b>	The vehicle is prevented from moving backward when operating the body.
<b>Forward/Reverse shift inhibitor</b>	This device makes it impossible to shift from forward to reverse when the vehicle's speed surpasses 4 km/hr <b>2.5 mph</b> .
<b>Anti-hunting system</b>	When running near a shift point, a smooth automatic shifting takes place.
<b>Neutral engine start system</b>	The engine is prevented from starting when the shift lever is not in neutral.



# EASY MAINTENANCE

## Advanced monitoring system

The Komatsu advanced monitoring system identifies maintenance items, reduces diagnostic times, indicates oil and filter replacement hours and displays abnormality codes. This monitor system helps to maximize machine production time.



**Wet multi-disc brakes and fully hydraulic braking systems** mean lower maintenance costs and higher reliability. Wet disc brakes are fully sealed to keep contaminants out, reducing wear and maintenance. Brakes require no adjustments for wear, leading to even lower maintenance. Added reliability is designed in the braking system with three independent hydraulic circuits providing hydraulic backup should one of the circuits fail. Fully hydraulic braking systems eliminate the air system so air bleeding is not required and water condensation, that can lead to contamination, corrosion and freezing, is eliminated.

## Extended oil change intervals

In order to minimize operating costs, oil change intervals have been extended:

- Engine oil: 500 hours
- Hydraulic oil: 4,000 hours

## Centralized arrangement of filters

The filters are centralized so that they can be serviced easily.

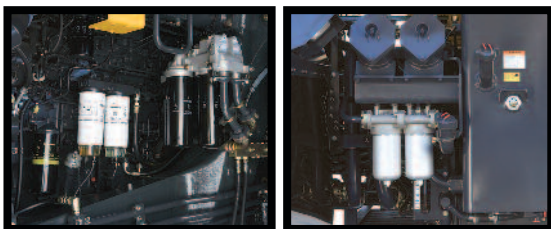

## Flange type rim



Flange type rims provide easy removal/installation of tires.

## Electric circuit breaker

A circuit breaker is used in important electric circuits that need to be restored quickly time when a problem occurs in the electrical system.



## Centralized greasing points

Greasing points are centralized at three locations.



## KOMTRAX Plus

As part of a complete service and support program, Komatsu equips every mining and quarry sized machine with KOMTRAX Plus. By using a satellite-based communication system, KOMTRAX Plus offers a new vision of monitoring your valuable assets by providing insight to critical operating metrics and information that can be used to increase availability, lower owning and operating costs and maximize fuel efficiency.

The KOMTRAX Plus information available on MyKomatsu.com allows service personnel and asset owners to review cautions, operational data, fuel consumption, payloads and key component measurements provided in forms of trends. With KOMTRAX Plus, knowledge becomes the power to fuel your productivity.



## Payload Meter (PLM)

PLM allows the production volume and working conditions on the dump truck to be analyzed and controlled directly via a personal computer. The payload is indicated both in the operator's cab and with a lamp on the outside of the truck. The system can store up to 2900 working cycles.

## SPECIFICATIONS



### ENGINE

Model	Komatsu SAA6D170E-5
Type	Water-cooled, 4-cycle
Aspiration	Turbo-charged, air-to-air after-cooled, cooled EGR
Number of cylinders	6
Bore x stroke	170 mm x 170 mm <b>6.69" x 6.69"</b>
Piston displacement	23.15 ltr <b>1,413 in<sup>3</sup></b>
Horsepower: SAE J1995	Gross 551 kW <b>739 HP</b>
ISO9249/SAE J1349	Net 533 kW <b>715 HP</b>
Rated rpm	2,000 rpm
Fan drive type	Mechanical
Maximum torque	339 kg·m <b>2,452 lb. ft</b>
Fuel system	Direct injection
Governor	Electronically controlled
Lubrication system: Method	Gear pump, force-lubrication
Filter	Full-flow type
Air cleaner	Dry type with double elements and precleaner (cyclonpack type), plus dust indicator
EPA Tier 3 and EU Stage 3A emission certified.	



### TRANSMISSION

Torque converter	3-elements, 1-stage, 2-phase
Transmission	Full-automatic, planetary type
Speed range	7 speeds forward and 1 reverse
Lockup clutch	Wet, multiple-disc clutch
Forward	Torque converter drive in 1st gear, direct drive in 1st lockup and all higher gears
Reverse	Torque converter drive
Shift control	Electronic shift control with automatic clutch modulation in all gears
Maximum travel speed	70.0 km/h <b>43.5 mph</b>



### AXLES

Rear Axle	Full-floating
Final drive type	Planetary gear
Ratios:	
Differential	3.538
Planetary	4.737



### SUSPENSION SYSTEM

Independent, hydropneumatic suspension cylinder with fixed throttle to dampen vibration	
Effective cylinder stroke (front suspension)	303 mm <b>11.9"</b>
Rear axle oscillation:	
Oil stopper	6.8°
Mechanical stopper	7.7°



### STEERING SYSTEM

Type	Fully hydraulic power steering with two double-acting cylinders
Supplementary steering	Manually controlled (meets ISO 5010, SAE J1511 and SAE J53)
Minimum turning radius	8.5 m <b>27'11"</b>
Maximum steering angle	39°



### CAB

Dimensions comply with ISO 3471 and SAE J1040-1988c ROPS (Roll-Over Protective Structure) standards.



### MAIN FRAME

Type	Box-sectioned structure
------	-------------------------



### BRAKES

Brakes meet ISO 3450 and SAE 1473 standards.

Service brakes:	
Front	Full-hydraulic control, caliper disc type
Rear	Full-hydraulic control, oil-cooled multiple-disc type
Parking brake	Spring applied, multiple-disc type
Retarder	Oil-cooled, multiple-disc rear brakes act as retarder
Secondary brake	Manual pedal operation
When hydraulic pressure drops below the rated level, parking brake is automatically actuated	

Brake surface	
Front	1936 cm <sup>2</sup> <b>300 in<sup>2</sup></b>
Rear	64230 cm <sup>2</sup> <b>9,956 in<sup>2</sup></b>



### BODY

Capacity:	
Struck	25.0 m <sup>3</sup> <b>32.7 yd<sup>3</sup></b>
Heaped (2:1, SAE)	34.2 m <sup>3</sup> <b>44.7 yd<sup>3</sup></b>
Payload	55 metric tons <b>61 U.S. tons</b>
Material	130 kg/mm <sup>2</sup> <b>184,900 psi</b> high tensile strength steel
Structure	V-shape body with V-bottom
Material thickness:	
Bottom	19 mm <b>0.75"</b>
Front	12 mm <b>0.47"</b>
Sides	9 mm <b>0.35"</b>
Target area	
(inside length x width)	6450 mm x 3870 mm <b>21'2" x 12'8"</b>
Dumping angle	48°
Height at full dump	8800 mm <b>28'10"</b>
Heating	Exhaust heating



### HYDRAULIC SYSTEM

Hoist cylinder	Twin, 2-stage telescopic type
Relief pressure	20.6 MPa 210 kg/cm <sup>2</sup> <b>2,990 psi</b>
Hoist time	11.5 sec



### WEIGHT (APPROXIMATE)

Empty weight	43100 kg <b>95,020 lb</b>
Max. gross vehicle weight:	
Standard tire	99680 kg <b>219,760 lb</b>
Not to exceed max. gross vehicle weight, including options, fuel and payload	
Weight distribution:	
Empty: Front axle	47%
Rear axle	53%
Loaded: Front axle	32%
Rear axle	68%



### TIRES

Standard tire	24.00-35-36PR
---------------	---------------



### SERVICE REFILL CAPACITIES

Fuel tank	780 ltr. <b>206.1 U.S. Gal</b>
Engine oil	.80 ltr. <b>21.1 U.S. Gal</b>
Torque converter, transmission and retarder cooling	.215 ltr. <b>56.8 U.S. Gal</b>
Differential	.95 ltr. <b>25.1 U.S. Gal</b>
Final drives (total)	.42 ltr. <b>11.1 U.S. Gal</b>
Hydraulic system	.122 ltr. <b>32.2 U.S. Gal</b>
Suspension (total)	.556 ltr. <b>14.7 U.S. Gal</b>



## DIMENSIONS

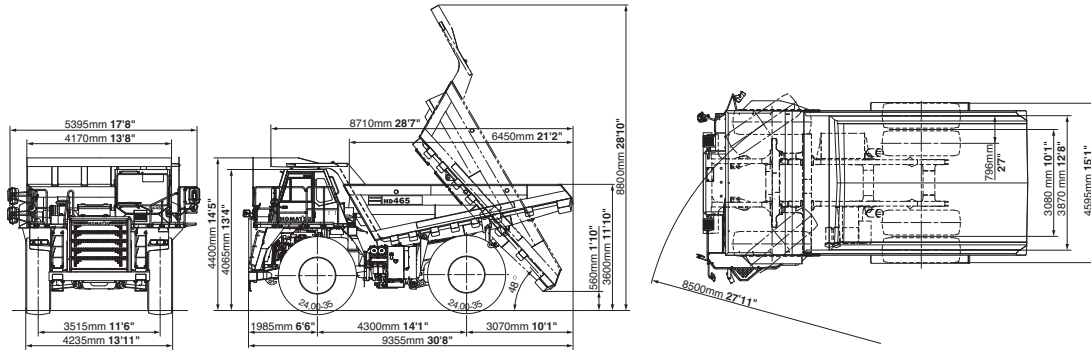

## TRAVEL PERFORMANCE

To determine travel performance:  
 Read from gross weight down to the percent of total resistance. From this weight-resistance point, read horizontally to the curve with the highest obtainable speed range, then down to maximum speed. Usable rimpull depends upon traction available and weight on drive wheels.

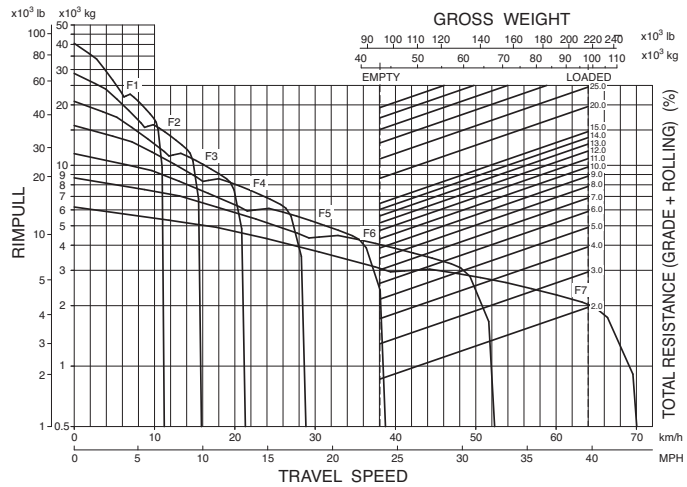

## BRAKE PERFORMANCE

To determine brake performance:  
 These curves are provided to establish the maximum speed and gearshift position for descents on roads with a given distance. Read from gross weight down to the percent of total resistance. From this weight-resistance point, read horizontally to the curve with the highest obtainable speed range, then down to maximum descent speed the brakes can handle without exceeding cooling capacity.

### Grade distance: Continuous descent

GRADE DISTANCE : CONTINUOUS DESCENT

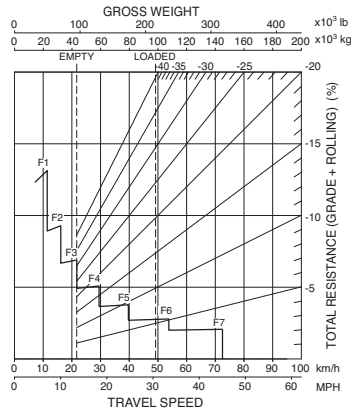

### Grade distance: 450 m (1,480 ft)

GRADE DISTANCE : 450 m (1,500 ft)

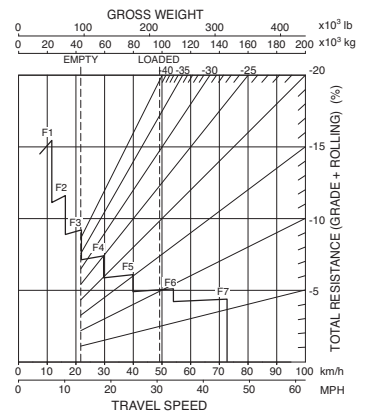

### Grade distance: 600 m (1,970 ft)

GRADE DISTANCE : 600 m (2,000 ft)

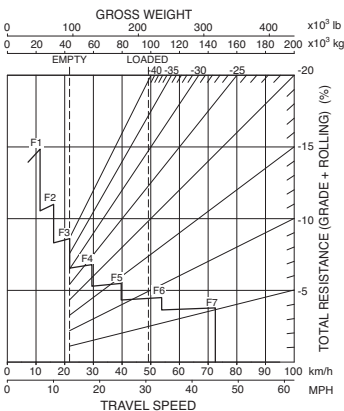

### Grade distance: 900 m (2,950 ft)

GRADE DISTANCE : 900 m (3,000 ft)

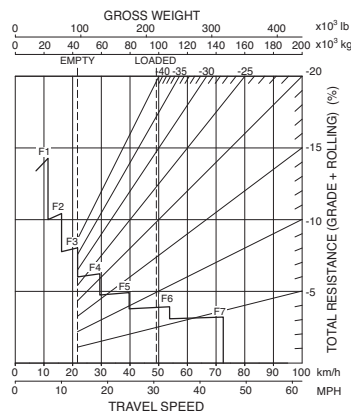

### Grade distance: 1500 m (4,920 ft)

GRADE DISTANCE : 1500 m (5,000 ft)

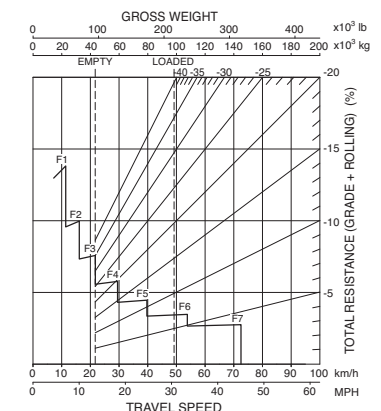



## STANDARD EQUIPMENT

### ENGINE:

- AISS (Automatic Idling Setting System)
- Alternator, 75A/24V
- Batteries, 2 x 12V/240Ah
- Engine, Komatsu SAA6D170E-5
- Starting motor, 2 x 7.5 kW
- Variable horsepower system

### CAB:

- 12 Volt outlet port
- Air conditioner/heater/defroster/ electronically controlled
- Ashtray and cigarette lighter
- Cup holder
- Electronic hoist control system
- Electronic maintenance display/monitoring system
- Electronic windows
- Operator seat, reclining, suspension type with retractable 78 mm 3" width seat belt
- Passenger seat with retractable 78 mm 3" width seat belt

- ROPS cab with FOPS Level 2, sound suppression type
- Radio, AM/FM with cassette
- Seat, air suspension
- Space for lunch box
- Steering wheel, tilt and telescopic
- Sun visor
- Tinted glass
- Two doors, left and right
- Windshield washer and wiper (with intermittent feature)

### LIGHTING SYSTEM:

- Back-up light
- Hazard lights
- Headlights with dimmer switch
- Indicator, stop and tail lights

### GUARD AND COVERS:

- Drive shaft guard (front and rear)
- Engine and transmission underguards
- Exhaust thermal guard
- Fire protective covers

### BODY:

- Body exhaust heating
- Cab guard, left side
- Spill guard, 150 mm 6"

### OTHER:

- Alarm, backup
- Automatic Retard Speed Control (ARSC)
- Centralized greasing
- Coolant temperature alarm and light
- Electric circuit breaker, 24V
- Front brake cut-off system
- Hand rails for platform
- Horn, electric
- KOMTRAX Plus with PLM and ORBCOMM
- Ladders, left and right hand side
- Mud guards
- Overrun warning system
- PLM payload meter
- Rearview mirrors
- Supplementary steering, automatic
- Under view mirrors



## OPTIONAL EQUIPMENT

### BODY:

- Angled front stairway
- Body liner
- Deck mounted muffler, no body heat
- Deck mounted muffler, with body heat

### LIGHTING SYSTEM:

- Back work lights, RH and LH side
- Fog lights

### TIRES:

- 24.00 R35

### OTHER:

- ASR (Automatic spin regulator)
- ABS (Antilock brake system)
- Fast fill fuel system
- High altitude controller

Standard equipment may vary for each country. This specification sheet may contain attachments and optional equipment that are not available in your area. Please consult your Komatsu distributor for detailed information.

# KOMATSU®

