

KOMATSU®

PC5500-6 Mining Shovel

OPERATING WEIGHT
531-549 ton **1,170,000-1,210,000 lb**

SHOVEL CAPACITY
29 m³ **38 yd³ SAE 2:1 heaped**

BACKHOE CAPACITY
29 m³ **38 yd³ SAE 1:1 heaped**

PC
5500

HYDRAULIC SHOVEL



Photo may include optional equipment.

WALK-AROUND

Komatsu Technology and Expertise

- Quality management ISO 9001 certified
- Environmental Management ISO 14001 certified
- High, consistent quality through continuous investment in personnel, design and manufacturing systems and processes

Reliability and Durability

Designed for lower operating costs

- Robust structural design developed from field experience and finite element analysis
- Extended life undercarriage wear parts
- Large diameter rollers, idlers and sprockets
- Large surface contact area with extensive precision hardening reduces wear
- Hardened track link pin bores

Productivity

Designed for more tons per hour

- Powerful digging forces
- Easy bucket filling
- Proven attachment design
- All cylinders mounted under the shovel attachment for additional protection
- Buckets and Wear Packages to suit all material densities and ground conditions

Advanced Hydraulics

Extended reliability and control

- Comprehensive monitored filtration
- Simple open-circuit hydraulic system with high efficiency swing-out oil coolers



Large Comfortable Cab

Provides full shift comfort

- Komatsu low noise cab on multiple viscous mounts for reduced noise and vibration
- Large volume cab with full view front window (floor to ceiling) increases operator view
- Comprehensive climate control with pressurized, filtered air ventilation and air conditioning
- High specification multi-adjustable air suspension seat, redesigned for mining
- Well elevated operator position provides superior all around view

MATCHED FOR
150 to 320 U.S. ton
TRUCKS

SHOVEL AND BACKHOE
BUCKET CAPACITY
29 m³ 38 yd³



Photo may include optional equipment.

Powerful Diesel Engines

Two Komatsu SDA12V159E-2 engines

- Rated (each) 940 kW **1260 HP**, at 1800 rpm
- Electronic engine management
- Low engine emission levels – meets EPA Tier 2 emission regulations
- Time saving oil management system as standard equipment; Centinel Engine Oil Management, Engine Reserve Oil Supply and Eliminator Oil Filter systems

Easy Maintenance

Simple, common-sense design gives quick, easy access to all major components

- Hydraulically operated ground access ladder
- Generous access to all major service points from machinery house floor level
- Enclosed, internally lit machinery house with wall separating engine from pump area
- Automatic central lubrication
- Electronic Control System (ECS) provides real-time information from the operating systems of the machine
- Ground-level access to hydraulically powered drop-down service center with Wiggins connections

SPECIFICATIONS



DIESEL DRIVE

Model 2 x Komatsu SDA12V159E-2 Tier 2 certified
 Type 4-cycle, water-cooled, direct injection
 Aspiration Turbocharged and aftercooled
 Number of cylinders 12
 Rated power 2 x 940 kW **1260 HP** @ 1800 rpm
 (SAE 1995/J1349)
 Controller/Monitoring Quantum
 The integrated engine oil & filter system combining the oil stabilizing systems, Reserve and Centinel, with the Eliminator self cleaning oil filter extends, with oil analysis, the oil change interval to 4000 hours. (not available in Australia)



ELECTRICAL SYSTEM

System 24 V
 Batteries (series/parallel) (diesel version) 2 x 6 x 12 V
 Alternator 2 x 100 A
 Standard working lights 8 Xenon lights
 Standard service lights 14 lights



HYDRAULIC SYSTEM

The power train consists of two main drives. Diesel engines or electric motors can be supplied. Each connected to a gearbox and 3 identical main pumps which draw hydraulic oil from an unpressurized hydraulic tank. Open circuit hydraulics provide maximum cooling and filtering efficiency.
 Rated flow (total output) 4200 ltr/min **1,110 U.S. gpm**
 Relief valve setting 310 bar **4,495 psi**
 Swing flow rate 700 ltr/min **185 U.S. gpm**
 High pressure in-line filters 200 micron
 (one per pump located at the valve blocks)
 Full flow return line filters (10 double elements) 10 micron
 (at head of hydraulic tank)
 Case drain/by-pass return line filters 3 micron
 The four-circuit system features a load-limiting governor with oil delivery summation to the working circuits and incorporates pressure cut-off control. Hydropilot prioritizes hydraulic flow giving smooth hydraulic response, simple hydraulic system layout, and a reduced number of components. Filtration is at the oil intake to pumps, valve blocks, heat exchangers and the oil tank.



DRIVES AND BRAKES

Travel control 2 foot pedals
 Gradeability Up to 50%
 Travel speed (maximum) 2.1 km/h **1.4 mph**
 Service brake Hydraulic
 Parking brake Wet, multiple-disc



COOLING SYSTEM

The high capacity engine radiators are cooled by hydraulically driven fans for superior cooling efficiency and require little maintenance. The hydraulic system includes four large swing-out vertical air-to-oil hydraulic coolers with temperature-regulated hydraulically driven fans.



SWING SYSTEM

Hydraulic motors and drives 2
 Swing brake, service Hydraulic
 Swing brake, parking Wet, multiple-disc
 Swing ring teeth External
 Swing speed (maximum) 3.1 rpm



ELECTRIC DRIVE

Type 2 x Squirrel-cage induction motors
 Power output 2 x 900 kW
 Voltage 6600 V*
 Amperage (approximate) 215 A
 Start-up Soft start each motor in succession
 Frequency (standard) 50 Hz @ 1500 rpm
 Optional frequency 60 Hz @ 1800 rpm

*Other voltages available on request



UNDERCARRIAGE

Undercarriage consists of one center carbody and two track frames, each side attached by 80 high torque bolts.
 Center frame H-type
 Track frame Steel box-section
 Track adjustment Automatic hydraulic type
 Number of shoes 46 each side
 Number of top rollers 3 each side
 Number of bottom rollers 7 each side



AUTOMATIC CENTRALIZED LUBRICATION

Two hydraulically powered Lincoln single line automatic lubrication systems are provided as standard, complete with time and volume variable controls. Activity and malfunction events are linked to the ECS. The central lube grease system is supplied from a refillable 300 liter **80 gal.** container. A second, identical system supplies open gear lubricant to the swing ring teeth through a lube pinion. Replenishment of the containers is through the service center.



SERVICE REFILL CAPACITIES

Hydraulic oil tank 3800 ltr **1,000 U.S. gal**
 Hydraulic system 6000 ltr **1,585 U.S. gal**
 Fuel 10800 ltr **2,853 U.S. gal**
 Engine coolant 2 x 360 ltr **2 x 95 U.S. gal**
 Engine oil 2 x 190 ltr **2 x 50 U.S. gal**
 Centinel engine oil make up tank 2 x 580 ltr **2 x 153 U.S. gal**



VEHICLE MONITORING SYSTEM

The Electronic Control System (ECS) digital diagnostic system, mounted in the operator's console, provides a text display of real-time and stored information about the operating systems of the machine. Non-serious and critical faults are immediately announced, and for major malfunctions the engines are also shut down. The integrated digital storage provides full event history, which can be downloaded with a laptop computer. The ability to electronically record service events provides precise service information to assist in reducing downtime.



The large welded steel cab is mounted with 18 viscous damping pads and sound insulated.

It is equipped with automatic climate control and is pressurized. The operator's seat is fully adjustable, air suspended, electrically heated and has a lap seat belt. Trainer's seat included.

Low effort joystick controls are electric over hydraulic and foot controls are for front shovel clam, crawler and swing brake.

Full instrumentation and Electronic Control System (ECS) are provided. Space in the console is provided for an additional monitor. AM/FM radio is included. The dual windshield wipers have two-speed and intermittent operation (water reservoir 7 liters **1.8 gal.**). Amenities include a wash basin with running water (water

reservoir 50 liters **13 gal.**), refrigerator, and storage cabinets. Powered mirrors are adjustable from inside the cab.

There are left and right-hand sliding windows. All windows are tinted parsol green. External metal louvers are provided on the cab side windows.

Cab engineering standards are;

- ISO 3449 Falling Objects Protection Structure (FOPS) Level 2
- ISO 6396 Noise in operator s cab is 76dB(A)
- ISO 2631-1/5349-1 Vibration and Shock
- Air conditioner10 kW **34,120 Btu/hr**
- Heater/Defroster (Diesel version)10 kW **34,120 Btu/hr**
- Heater/Defroster (Electric version)12 kW **40,940 Btu/hr**



BASIC MACHINE WITH COUNTERWEIGHT

A	1350 mm	53"	H	3310 mm	10'10"
B	1800 mm	71"	I	3100 mm	10'2"
C _A	7540 mm	24'9"	J	7910 mm	25'11"
C _B	7990 mm	26'3"	K	8610 mm	28'3"
D	2715 mm	8'11"	L	3970 mm	13'0"
E	3712 mm	12'2"	M	3300 mm	10'10"
F	7424 mm	24'4"	N	7900 mm	25'11"
G	9720 mm	31'11"	O	7260 mm	23'10"
			O _R	7550 mm	24'9"

Ground Clearance: 995 mm 3'3"

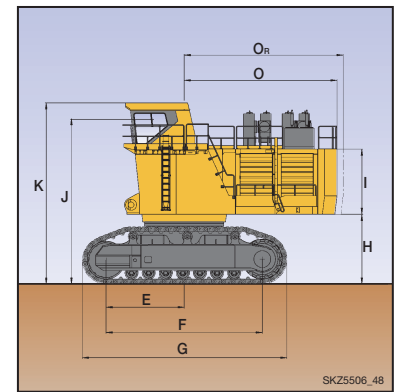
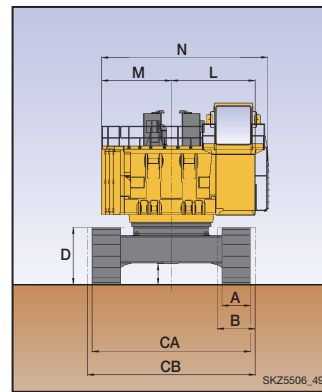

PC 5500 Backhoe:

Operating weight including 11000 mm **36'1"** boom, 5100 mm **16'9"** stick, 29 m³ **38 yd³** backhoe bucket, operator, lubricant, coolant, full fuel tank and standard equipment.

Shoe Width	Operating Weight	Ground Pressure
1350 mm	535 t	23.9 N/cm ²
53"	1,180,000 lb	34.7 psi
1800 mm	549 t	18.3 N/cm ²
71"	1,210,000 lb	26.5 psi

PC 5500 Front Shovel:

Operating weight including 7600 mm **24'11"** boom, 5600 mm **18'4"** stick, 29 m³ **38 yd³** shovel bucket, operator, lubricant, coolant, full fuel tank and standard equipment.

Shoe Width	Operating Weight	Ground Pressure
1350 mm	531 t	23.1 N/cm ²
53"	1,170,000 lb	33.5 psi
1800 mm	545 t	18.2 N/cm ²
71"	1,200,000 lb	26.4 psi

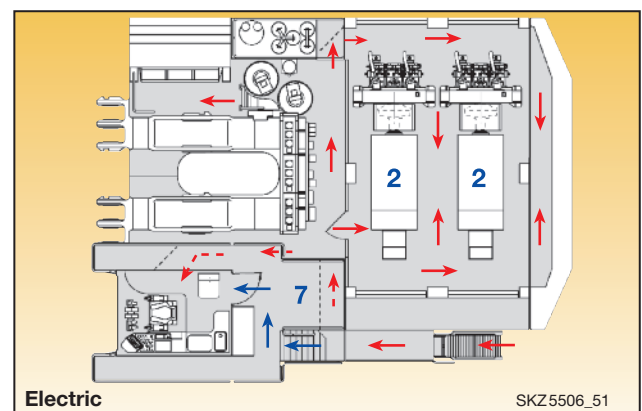
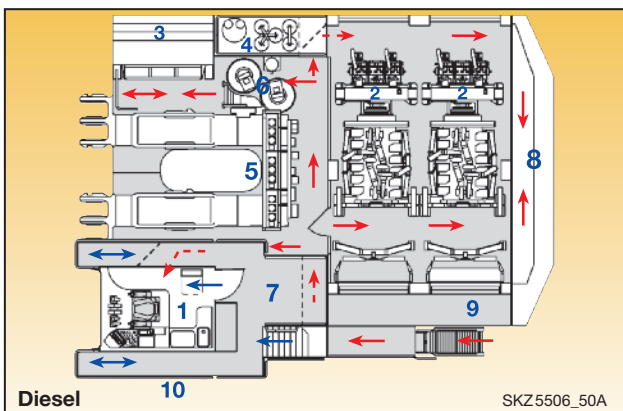

Explanation

- | | | |
|-----------------------|-----------------|------------------------------------|
| 1 Operator's Cab | 5 Valve Blocks | 9 Autolube Systems (on upper deck) |
| 2 Power Trains | 6 Swing Motors | 10 Secondary Egress |
| 3 Hydraulic Cooler | 7 Fuel Tank | |
| 4 Hydraulic Reservoir | 8 Counterweight | |

Variation for Electric Drive Version

- 2 Electric Motor
- 7 High Voltage Electric Cabinet

Walkways → Lower-Level
← Upper-Level

PC5500-6 MINING SHOVEL

PRODUCTIVITY FEATURES



BACKHOE BUCKET, STICK AND BOOM COMBINATION

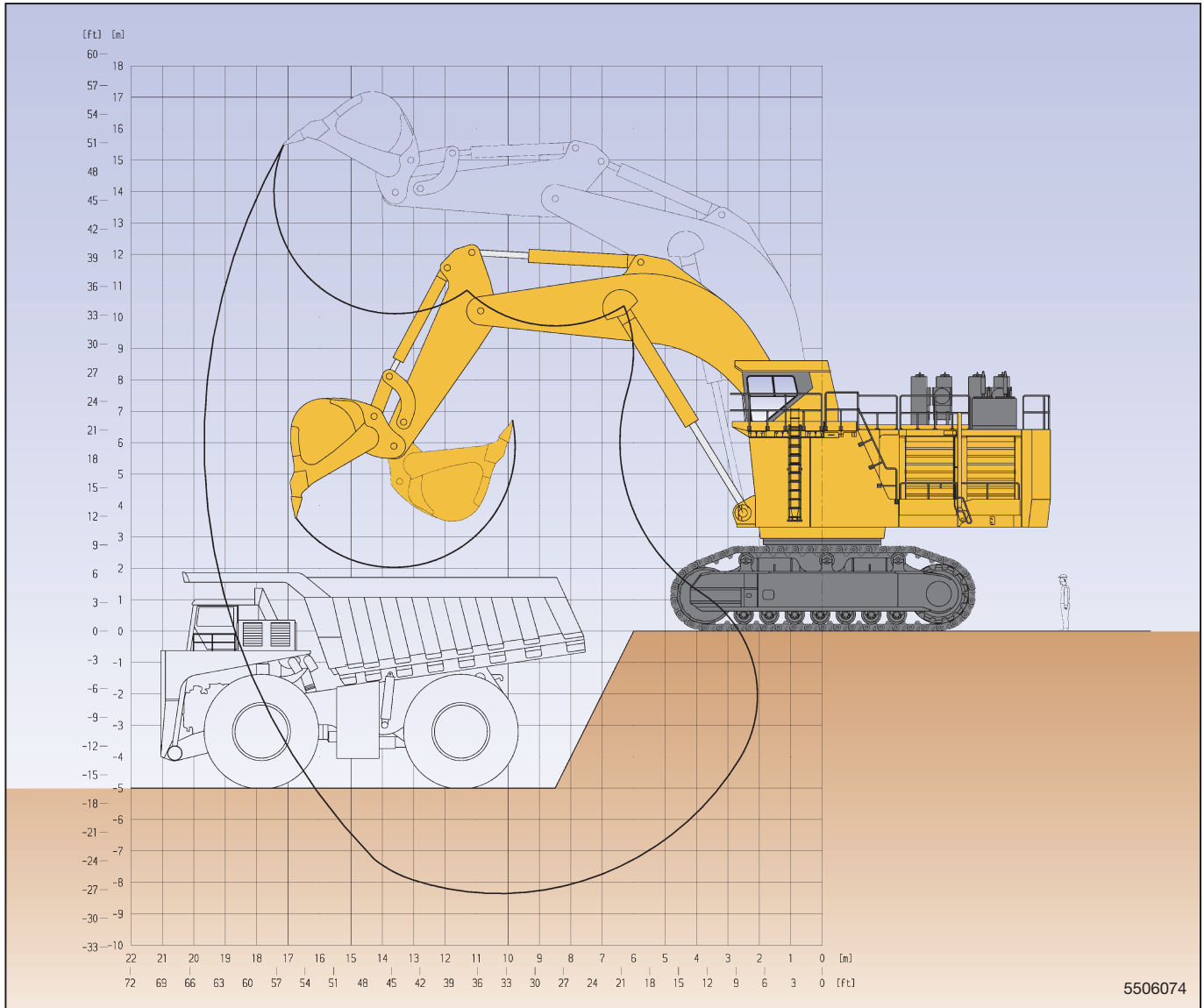

5506074

Boom length	11000 mm	36'1"
Stick length	5100 mm	16'9"
Break-out force (SAE)	1450 kN	326,250 lb
Tear-out force (SAE)	1290 kN	290,250 lb

Max. digging height	15500 mm	50'10"
Max. dumping height	10100 mm	33'2"
Max. digging depth	8300 mm	27'3"
Max. digging reach	19800 mm	65'0"
Max. digging reach at ground level	18700 mm	61'4"

Bucket Capacity (Heaped 1:1) SAE		Width		Teeth	Weight*		Max. Material Density (Loose)		Wear Package	Recommended Mining Uses
m ³	yd ³	mm	ft and in	qty	t	lb	t/m ³	lb/yd ³		
26.0	34.0	4380	14'4"	5	32.2	71,000	2.0	3,400	WP-3	Heavy Duty
29.0	38.0	4380	14'4"	5	33.1	73,000	1.8	3,000	WP-2	Standard Mining

Alternative buckets on request

* Weight includes Backhoe Bucket, Stick and Boom Combination



SHOVEL BUCKET, STICK AND BOOM COMBINATION

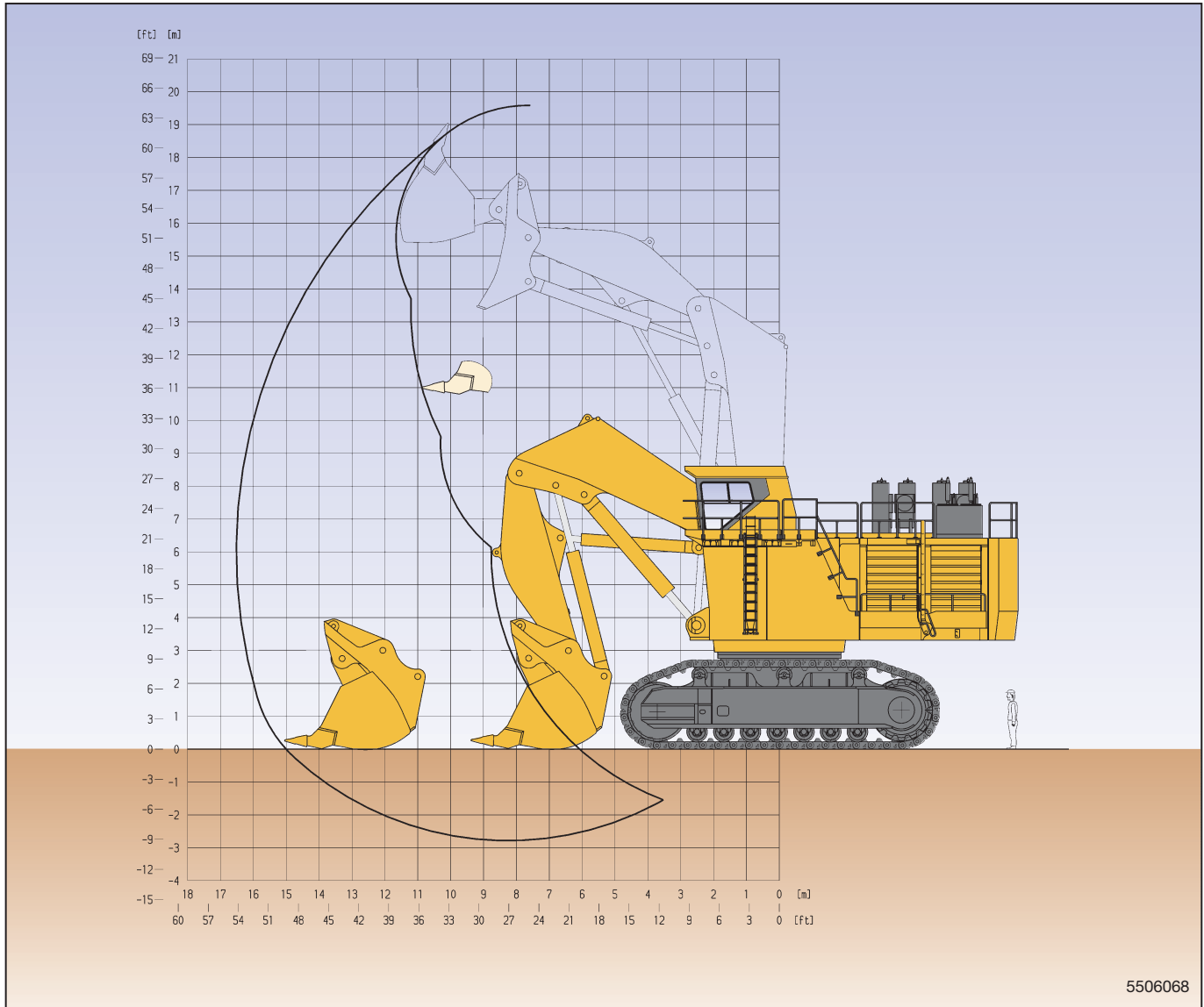

5506068

Boom length	7600 mm	24'11"
Stick length	5600 mm	18'4"
Break-out force (SAE)	1865 kN	419,200 lb
Crowd force (SAE)	1870 kN	420,300 lb

Max. cutting height	19500 mm	64'0"
Max. dumping height	13300 mm	43'8"
Max. digging depth	2700 mm	8'10"
Max. digging reach	16500 mm	54'2"
Level crowd at ground level	5600 mm	18'5"
Bucket opening width	2700 mm	8'10"

Bucket Capacity (Heaped 2:1) SAE		Width		Teeth	Weight*		Max. Material Density (Loose)		Wear Package	Recommended Mining Uses
m³	yd³	mm	ft and in	qty	t	lb	t/m³	lb/yd³		
21.0	27.5	4410	14'6"	5	48.6	107,200	2.6	4,400	WP-4	Heavy Duty
26.0	34.0	4570	15'0"	6	48.9	107,800	2.2	3,700	WP-3	Standard Mining
29.0	38.0	4570	15'0"	6	49.5	109,100	1.9	3,200	WP-3	Standard Mining

Alternative buckets on request

* Weight includes Shovel Bucket, Stick and Boom Combination



STANDARD EQUIPMENT

Hydraulic Mining Shovel with Diesel Drive will comprise:

● FRONT SHOVEL ATTACHMENT

7.6 m **24'11"** boom and 5.6 m **18'4"** stick complete with cylinders. 29 m³ **38 yd³** (SAE 2:1) shovel bucket with mechanical teeth and lip system.

OR

● BACKHOE ATTACHMENT

11.0 m **36'1"** boom and 5.1 m **16'9"** stick with 29 m³ **38 yd³** (SAE 1:1) bucket with mechanical teeth and lip system.

● CRAWLER UNDERCARRIAGE

Heavy-duty shovel type undercarriage consisting of a center carbody and 2 heavy box-type track frames, each having 7 bottom rollers, 3 top rollers, and 1350 mm **53"** cast steel track shoes. Hydraulic track adjustment and parking brake provided.

● SUPERSTRUCTURE

The main frame mounted over an externally toothed swing circle carries the main drive module, including two Komatsu SSA12V159-2 diesel engines, oil and fuel reservoirs, counterweight, operator's cab and base.

● LIGHTING

8 Xenon high performance working lights.
14 service lights throughout platform.

● OPERATOR'S CAB

Fully enclosed steel cab which incorporates the ISO 3449 standard FOPS Level 2 structure and CARRIER SÜTRAK air-conditioning unit. Mounted on viscous pads. GRAMMER full suspension operator's seat with lap-belt. A trainer seat. Full selection of controls, switches, and Electronic Control System (ECS). Joystick and pedal-operated controls are electric over hydraulic. Dual windshield wipers with two-speed and intermittent operation. (reservoir 7 ltr **1.8 gal**). AM-FM radio. External metal sun blinds. Left and right-hand sliding windows. All windows tinted parsol green.

● LUBRICATION

LINCOLN central lubrication for basic machine, attachment, and bucket. 300 ltr **80 gal** refillable container from service center.

LINCOLN automatic pinion lubrication system for swing circle teeth with 300 ltr **80 gal** refillable container from service center.

Service center (diesel version only as standard) on hydraulic arm carrying WIGGINS fluid receiving connectors for filling of fuel, engine oil and coolant, hydraulic oil, grease, cab water and the evacuation of coolant, and hydraulic and engine oils.

● ACCESSORIES

Acoustic travel alarm
Hydraulically actuated ground access ladder
Electric air horn
Emergency stops, ground level



OPTIONAL EQUIPMENT

- 1800 mm **71"** track shoes
- Additional cab heater, -15°C **5°F**
- Cable reel (Electric version)
- Drive gear box protection
- Drive motor protection, top
- Electric drive
- Fire suppression and detection system
- Independant LINCOLN central lubrication system for bucket
- Kim Hotstart
- Lighting, extra or alternative
- Material for -40°C **-40°F** spec
- Material for -50°C **-58°F** spec
- Oil for -25°C **-13°F** to +15°C **59°F**
- Oil for +5°C **41°F** to +55°C **131°F**
- Oil for Arctic, -40°C **-40°F** to +10°C **50°F**

FRONT SHOVEL ATTACHMENT

- Arm cylinder sliding guard
- Bucket, 21.0 m³ **27.5 yd³**
- Bucket, 26.0 m³ **34.0 yd³**
- Boom cylinder sliding guard
- Handrails and step, boom
- Wear package #1, bucket
- Wear package #2, bucket
- Wear package #4, bucket

BACKHOE ATTACHMENT

- Bucket, 26.0 m³ **34.00 yd³**
- Bucket, 30.0 m³ **39.24 yd³**
- Bucket cylinder sliding guard
- Handrails and step, boom
- Wear package #1, bucket
- Wear package #2, bucket
- Wear package #3, bucket

