

# Self Priming Centrifugal Pumps

Ultra V Series® Basic Pump w/ UltraMate® Second Stage



Model VS3A60-B

Size 4" x 3"



VARIOUS PATENTS APPLY

**PUMP SPECIFICATIONS**

**Size:** 4" x 3" (102 mm x 76 mm) – Flanged.\*\*

**Casings:** Gray Iron 30.

Maximum Operating Pressure 249 psi (1717 kPa).\*

**Semi-Open Type, Two Vane Impellers:** Ductile Iron 65-45-12.

Handles 2-1/2" (63,5 mm) Diameter Spherical Solids.

**Impeller Shafts:** Alloy Steel 4150.

**Self-Cleaning Replaceable Wear Plates:** Carbon Steel 1015.

**Shimless Adjustable Cover Plates:** Gray Iron 30.

**Suction Flange:** Gray Iron 30.

**Bearing Housings:** Gray Iron 30.

**Seal Plates:** Gray Iron 30.

**Shaft Sleeves:** Alloy Steel 4130.

**Radial Bearings:** Open Single Row Ball.

**Thrust Bearings:** Open Double Row Ball.

**Bearing and Seal Cavity Lubrication:** SAE 30 Non-Detergent Oil.

**Gaskets:** Buna-N, Compressed Synthetic Fibers, Vegetable Fiber, PTFE, Cork, and Rubber.

**O-Rings:** Buna-N.

**Transition Chamber:** Ductile Iron 65-45-12.

**Hardware:** Standard Plated Steel.

**Brass Pressure Relief Valves.**

**Bearing and Seal Cavity Oil Level Sight Gauges.**

**Optional Equipment:** Automatic Air Release Valve. High Pump

Temperature Shutdown Kit. Stainless Steel/G-R Hard Iron Impellers, Wear Plates and Seal Plates. 120/240 Volt Casing Heater.

\*\* Optional Gray Iron 30 Flange Kits Available as Follows (See Price Sheets):

3" Female NPT Discharge Flange Kit.

4" and 3" ASA Suction/Discharge Spool Flange Kits.

100 mm and 80 mm DIN 2527 (PN 16) Suction/Discharge Spool Flange Kits.

UltraMate®  
Second Stage

Ultra V  
Basic  
Pump

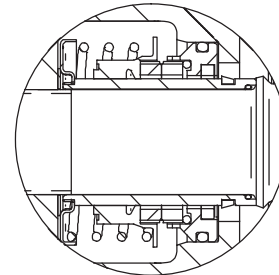
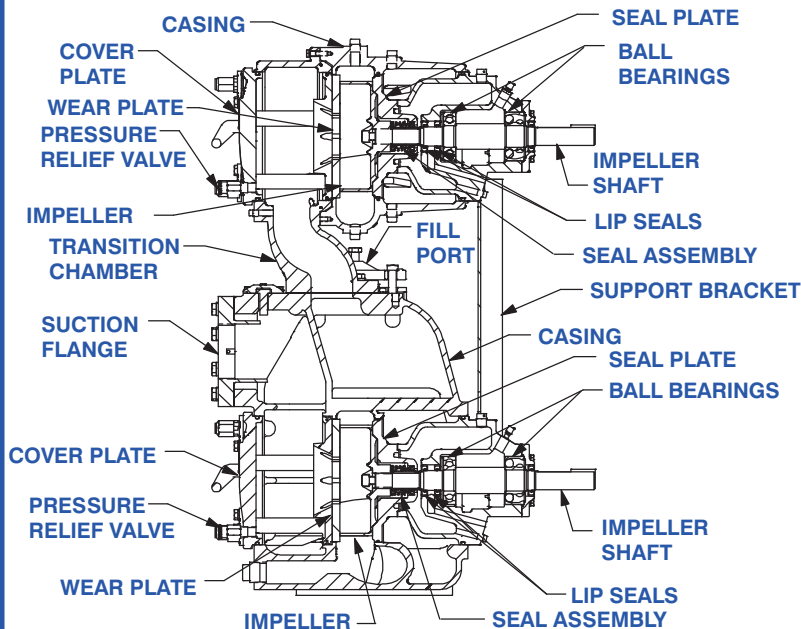

**SEAL DETAIL**

Cartridge Type, Mechanical, Oil-Lubricated, Double Floating, Self-Aligning. Silicon Carbide Rotating and Stationary Faces. Stainless Steel 316 Stationary Seat. Fluorocarbon Elastomers (DuPont Viton® or Equivalent). Stainless Steel 18-8 Cage and Spring. Maximum Temperature of Liquid Pumped, 160°F (71°C).\*

\* Consult Factory for Applications Exceeding Maximum Pressure and/or Temperature Indicated.



GORMAN-RUPP PUMPS

www.grpumps.com

Specifications Subject to Change Without Notice

Printed in U.S.A.

# Specification Data

SECTION 55, PAGE 3000

## APPROXIMATE DIMENSIONS and WEIGHTS

**NET WEIGHT:** 1040 LBS. (472 KG.)\*  
**SHIPPING WEIGHT:** 1175 LBS. (533 KG.)\*  
**EXPORT CRATE:** 42.9 CU. FT. (1,2 CU. M.)  
 \*WEIGHTS DO NOT INCLUDE OPTIONAL FLANGE KITS.

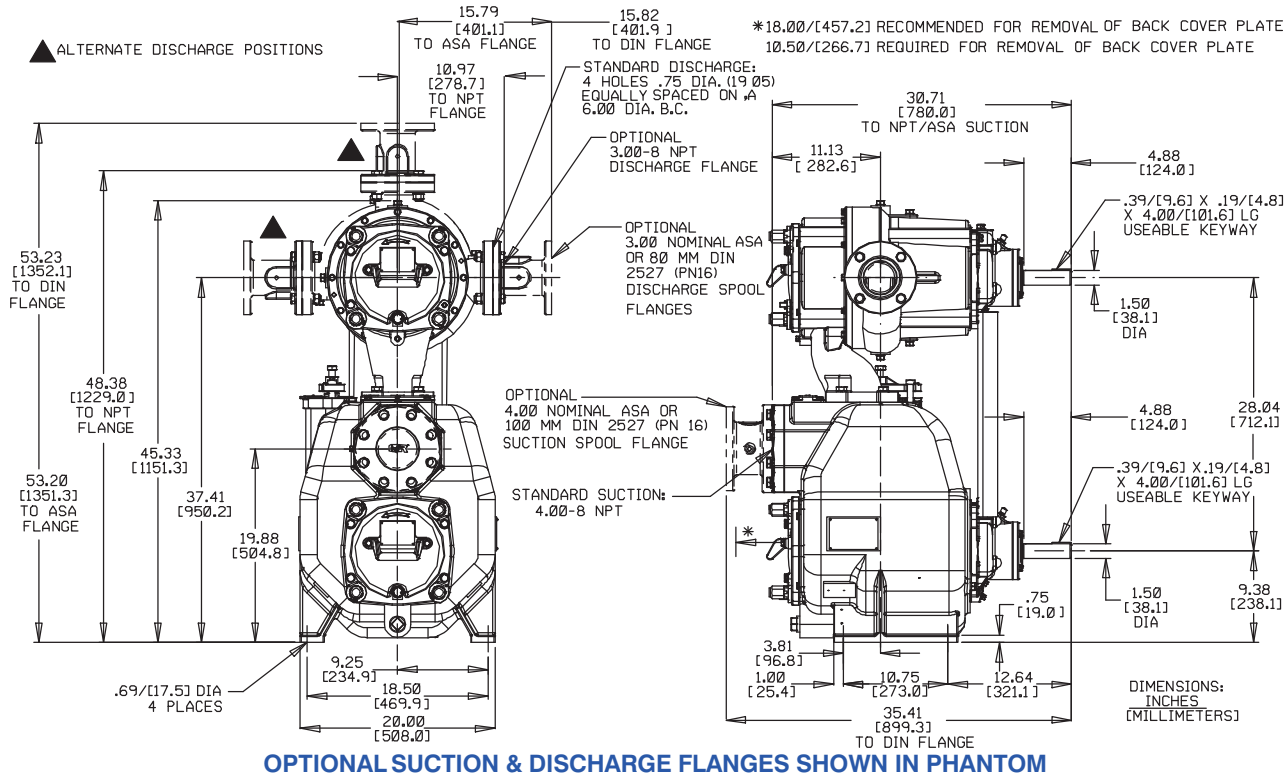

**TOTAL COMBINED H.P. SHOWN**

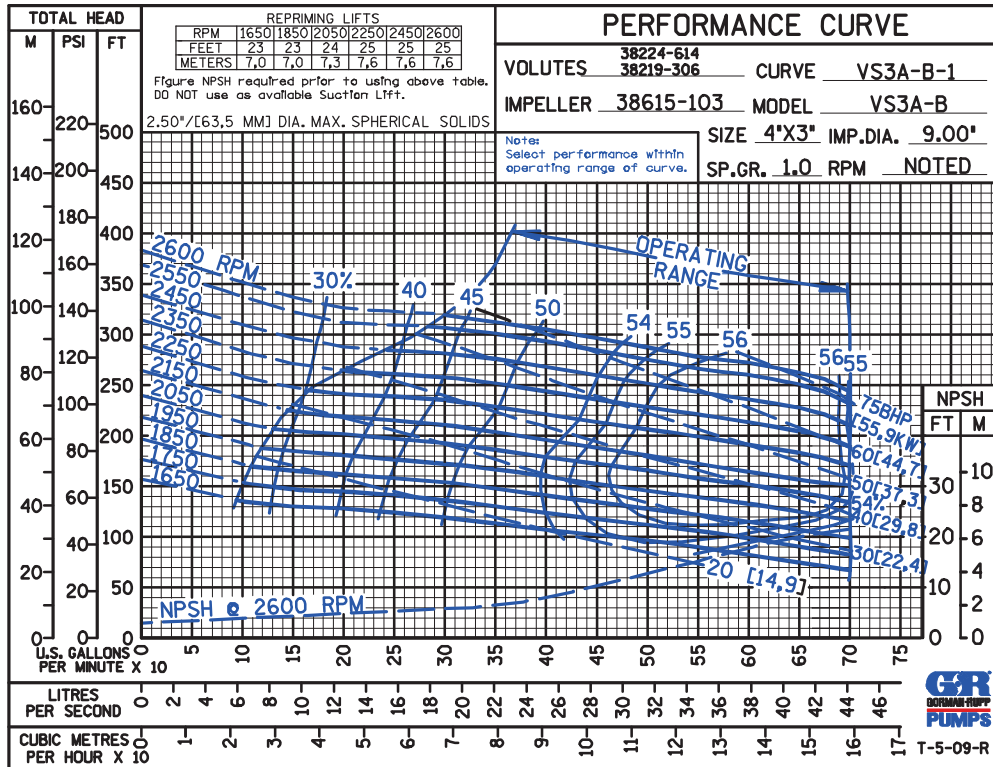

## GORMAN-RUPP PUMPS

www.grpumps.com

Specifications Subject to Change Without Notice

Printed in U.S.A.

TOTAL  
COMBINED  
H.P. SHOWN

PERFORMANCE  
BASED ON  
WATER

TRIMMED  
IMPELLER

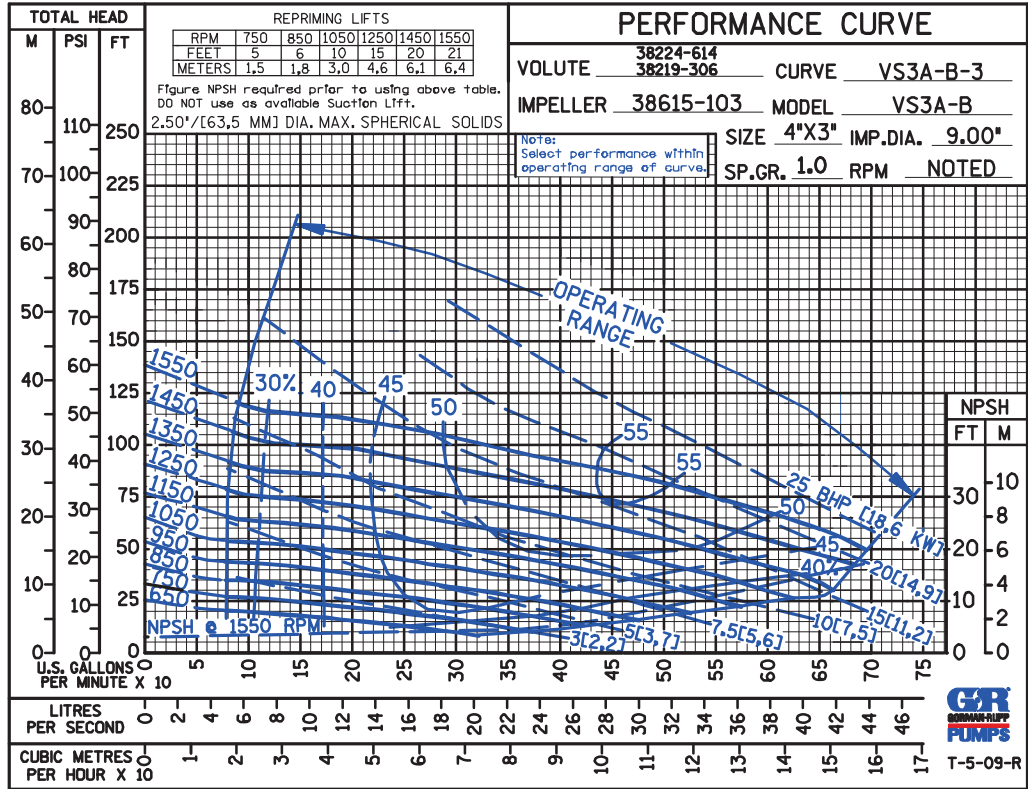

GORMAN-RUPP PUMPS

www.grpumps.com

Specifications Subject to Change Without Notice

Printed in U.S.A.