

# Self Priming Centrifugal Pumps

Ultra V Series® Basic Pump w/ UltraMate® Second Stage



Model VS3B60-B

Size 4" x 3"



VARIOUS PATENTS APPLY

**PUMP SPECIFICATIONS**

- Size:** 4" x 3" (102 mm x 76 mm) – Flanged.\*\*
- Casings:** Gray Iron 30.  
Maximum Operating Pressure 176 psi (1213 kPa).\*
- Semi-Open Type, Two Vane Impellers:** Ductile Iron 65-45-12.  
Handles 3" (76,2 mm) Diameter Spherical Solids.
- Impeller Shafts:** Alloy Steel 4150.
- Self-Cleaning Replaceable Wear Plates:** Carbon Steel ASTM A36.
- Shimless Adjustable Cover Plates:** Gray Iron 30.
- Suction Flange:** Gray Iron 30.
- Bearing Housings:** Gray Iron 30.
- Seal Plates:** Gray Iron 30.
- Shaft Sleeves:** Alloy Steel 4130.
- Radial Bearings:** Open Single Row Ball.
- Thrust Bearings:** Open Double Row Ball.
- Bearing and Seal Cavity Lubrication:** SAE 30 Non-Detergent Oil.
- Gaskets:** Buna-N, Compressed Synthetic Fibers, Vegetable Fiber, PTFE, Cork, and Rubber.
- O-Rings:** Buna-N.
- Transition Chamber:** Ductile Iron 65-45-12.
- Hardware:** Standard Plated Steel.
- Brass Pressure Relief Valves.**
- Bearing and Seal Cavity Oil Level Sight Gauges.**
- Optional Equipment:** Automatic Air Release Valve. High Pump Temperature Shutdown Kit. Stainless Steel/G-R Hard Iron Impellers, Wear Plates and Seal Plates. 120/240 Volt Casing Heater.
- \*\* Optional Gray Iron 30 Flange Kits Available as Follows (See Price Sheets):  
 3" Female NPT Discharge Flange Kit.  
 4" and 3" ASA Suction/Discharge Spool Flange Kits.  
 100 mm and 80 mm DIN 2527 (PN 16) Suction/Discharge Spool Flange Kits.

UltraMate®  
Second Stage

Ultra V  
Basic Pump

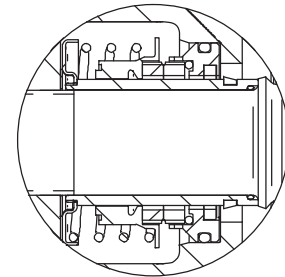
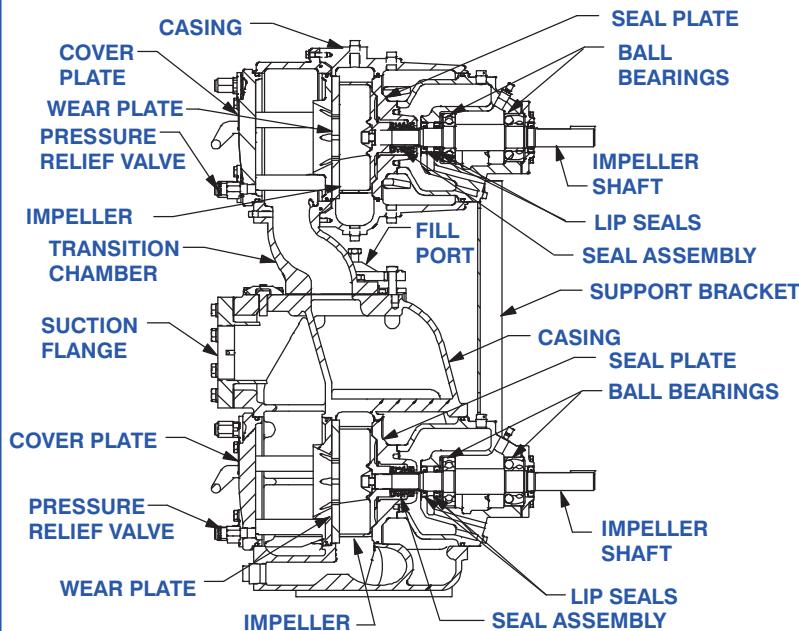

**SEAL DETAIL**

Cartridge Type, Mechanical, Oil-Lubricated, Double Floating, Self-Aligning. Silicon Carbide Rotating and Stationary Faces. Stainless Steel 316 Stationary Seat. Fluorocarbon Elastomers (DuPont Viton® or Equivalent). Stainless Steel 18-8 Cage and Spring. Maximum Temperature of Liquid Pumped, 160°F (71°C).\*

*\* Consult Factory for Applications Exceeding Maximum Pressure and/or Temperature Indicated.*



GORMAN-RUPP PUMPS

www.grpumps.com

Specifications Subject to Change Without Notice

Printed in U.S.A.

# Specification Data

SECTION 55, PAGE 3050

## APPROXIMATE DIMENSIONS and WEIGHTS

**NET WEIGHT:** 1120 LBS. (508 KG.)\*  
**SHIPPING WEIGHT:** 1195 LBS. (542 KG.)\*  
**EXPORT CRATE:** 42.9 CU. FT. (1,2 CU. M.)  
 \*WEIGHTS DO NOT INCLUDE OPTIONAL FLANGE KITS.

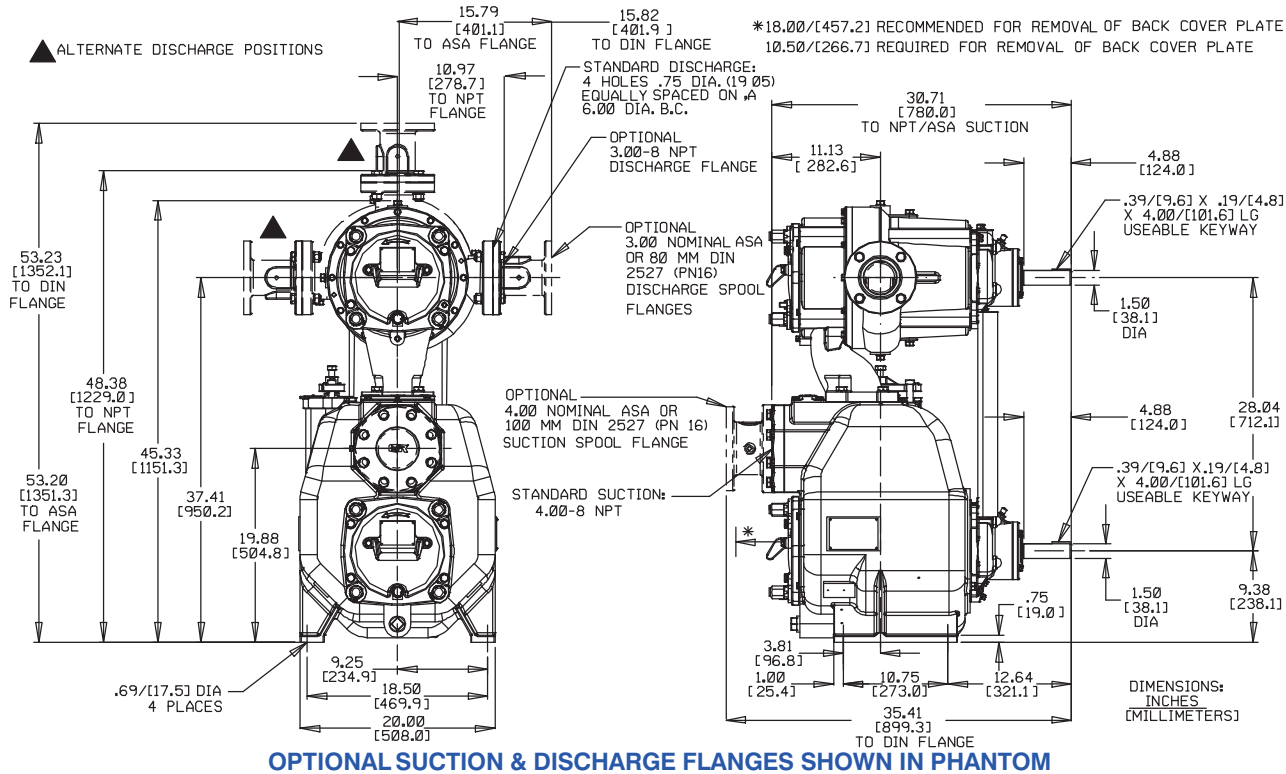

**TOTAL COMBINED H.P. SHOWN**

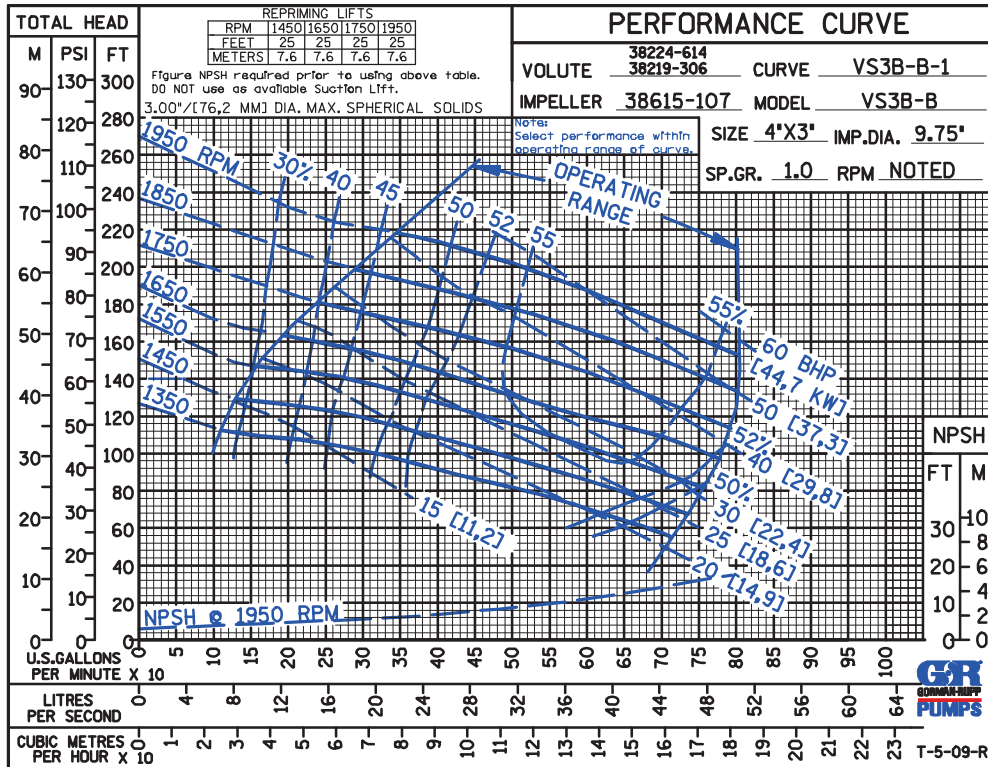

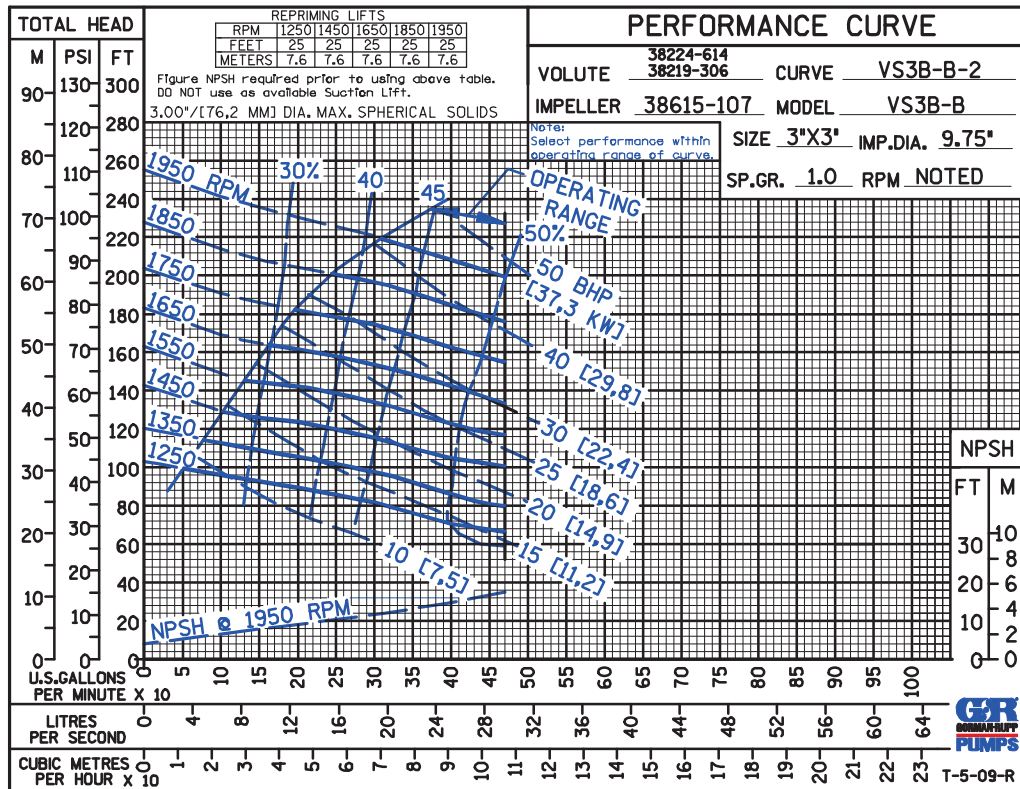
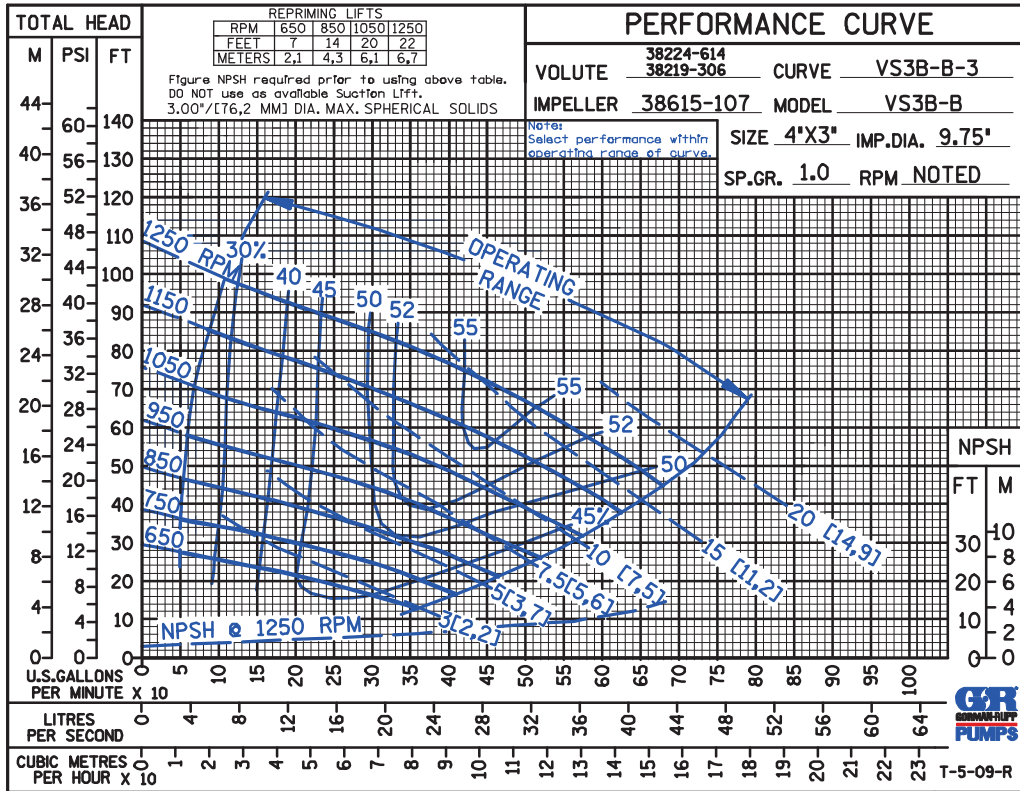

GORMAN-RUPP PUMPS

www.grpumps.com

Specifications Subject to Change Without Notice

Printed in U.S.A.

TOTAL  
COMBINED  
H.P. SHOWN

PERFORMANCE  
FOR REDUCED  
SUCTION  
BASED ON  
WATER

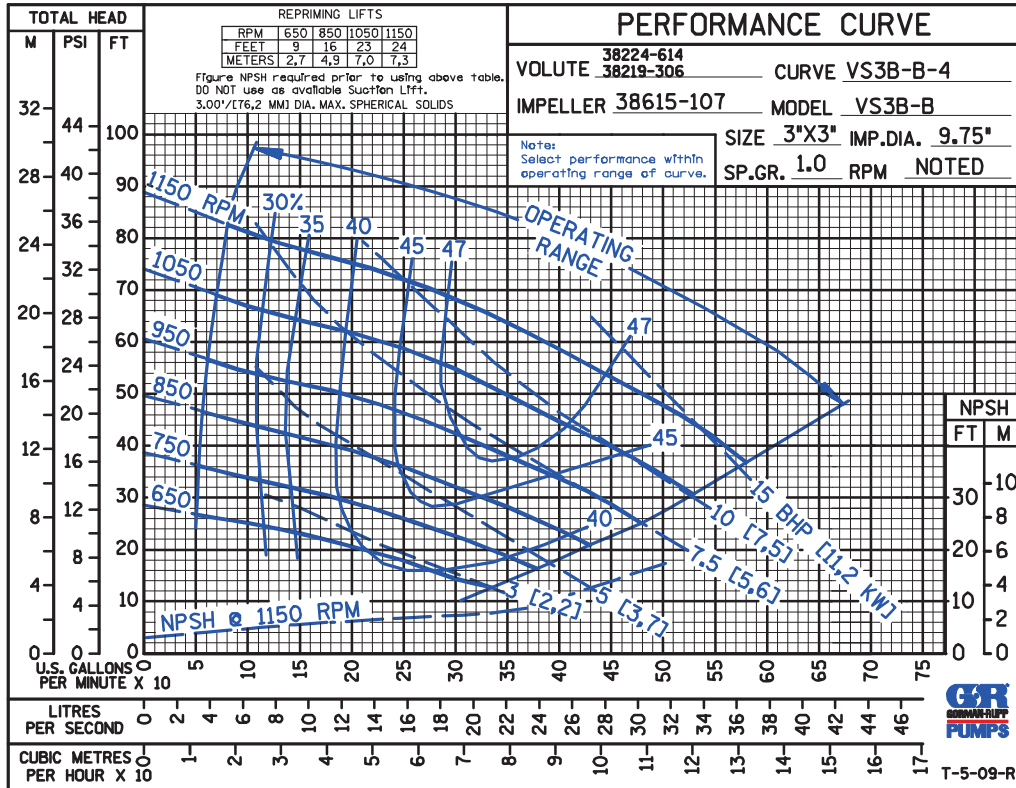

GORMAN-RUPP PUMPS

www.grpumps.com

Specifications Subject to Change Without Notice

Printed in U.S.A.