

Vertically Staged

Self Priming Centrifugal Pumps

Ultra V Series® Basic Pump w/ UltraMate® Second Stage



Model VS4A60-B

Size 6" x 4"



VARIOUS PATENTS APPLY

PUMP SPECIFICATIONS

- Size:** 6" x 4" (152 mm x 102 mm) – Flanged.**
- Casings:** Gray Iron 30.
Maximum Operating Pressure 229 psi (1579 kPa).*
- Semi-Open Type, Two Vane Impellers:** Ductile Iron 65-45-12.
Handles 3" (76,2 mm) Diameter Spherical Solids.
- Impeller Shafts:** Alloy Steel 4150.
- Self-Cleaning Replaceable Wear Plates:** Carbon Steel ASTM A36.
- Shimless Adjustable Cover Plates:** Gray Iron 30.
- Suction Flange:** Gray Iron 30.
- Bearing Housings:** Gray Iron 30.
- Seal Plates:** Gray Iron 30.
- Shaft Sleeves:** Alloy Steel 4130.
- Radial and Thrust Bearings:** Open Single Row Ball.
- Bearing and Seal Cavity Lubrication:** SAE 30 Non-Detergent Oil.
- Gaskets:** Buna-N, Compressed Synthetic Fibers, Vegetable Fiber, PTFE, Cork, and Rubber.
- O-Rings:** Buna-N.
- Transition Chamber:** Ductile Iron 65-45-12.
- Hardware:** Standard Plated Steel.
- Brass Pressure Relief Valves.**
- Bearing and Seal Cavity Oil Level Sight Gauges.**
- Optional Equipment:** Automatic Air Release Valve. High Pump Temperature Shutdown Kit. Stainless Steel/G-R Hard Iron Impellers, Wear Plates and Seal Plates. 120/240 Volt Casing Heater.
- ** Optional Gray Iron 30 Flange Kits Available as Follows (See Price Sheets):
4" Female NPT Discharge Flange Kit.
6" and 4" ASA Suction/Discharge Spool Flange Kits.
150 mm and 100 mm DIN 2527 (PN 16) Suction/Discharge Spool Flange Kits.

UltraMate®
Second
Stage

Ultra V
Basic
Pump

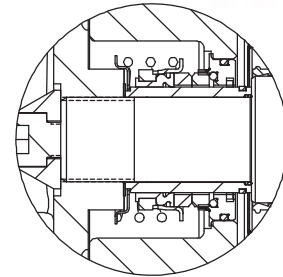
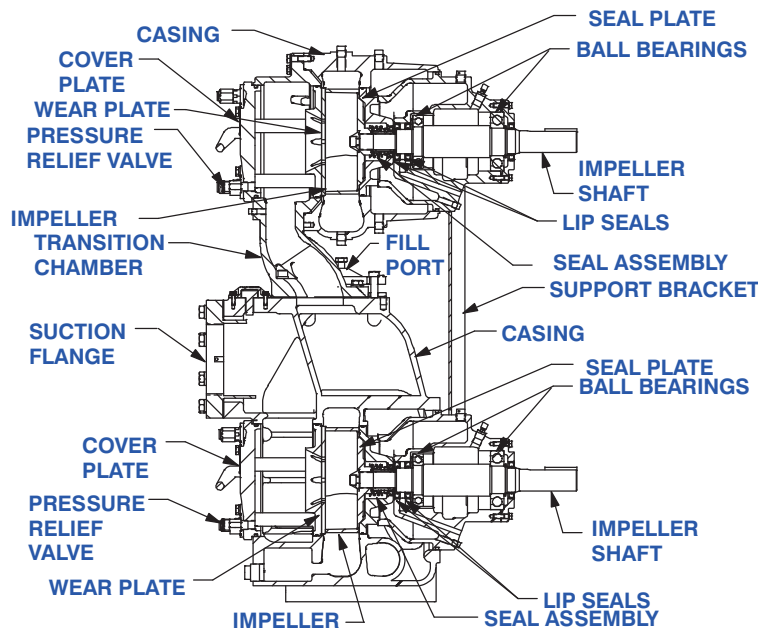

SEAL DETAIL

Cartridge Type, Mechanical, Oil-Lubricated, Double Floating, Self-Aligning. Silicon Carbide Rotating and Stationary Faces. Stainless Steel 316 Stationary Seat. Fluorocarbon Elastomers (DuPont Viton® or Equivalent). Stainless Steel 18-8 Cage and Spring. Maximum Temperature of Liquid Pumped, 160°F (71°C).*

* Consult Factory for Applications Exceeding Maximum Pressure and/or Temperature Indicated.



GORMAN-RUPP PUMPS

www.grpumps.com

Specifications Subject to Change Without Notice

Printed in U.S.A.

Specification Data

SECTION 55, PAGE 3100

APPROXIMATE DIMENSIONS and WEIGHTS

NET WEIGHT: 1650 LBS. (748 KG.)*
SHIPPING WEIGHT: 1725 LBS. (782 KG.)*
EXPORT CRATE: 60 CU. FT. (1,7 CU. M.)
 *WEIGHTS DO NOT INCLUDE OPTIONAL FLANGE KITS

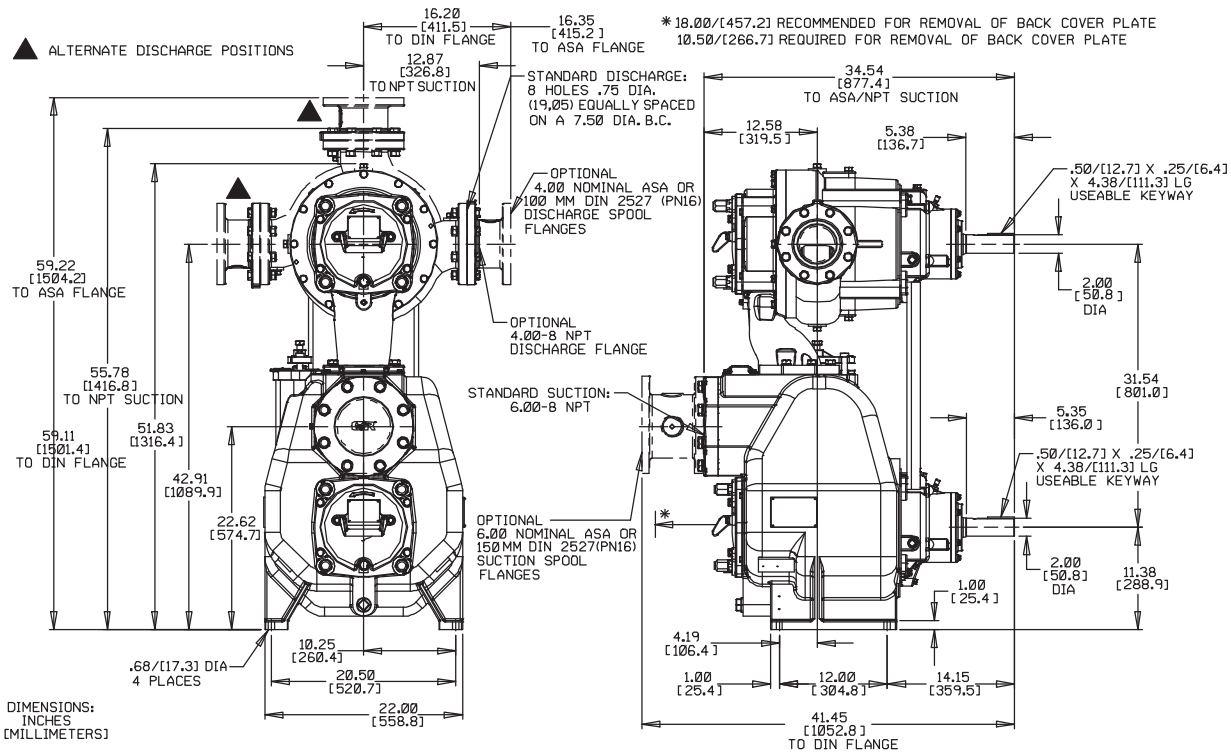

OPTIONAL SUCTION & DISCHARGE FLANGES SHOWN IN PHANTOM

Total Combined H.P. Shown

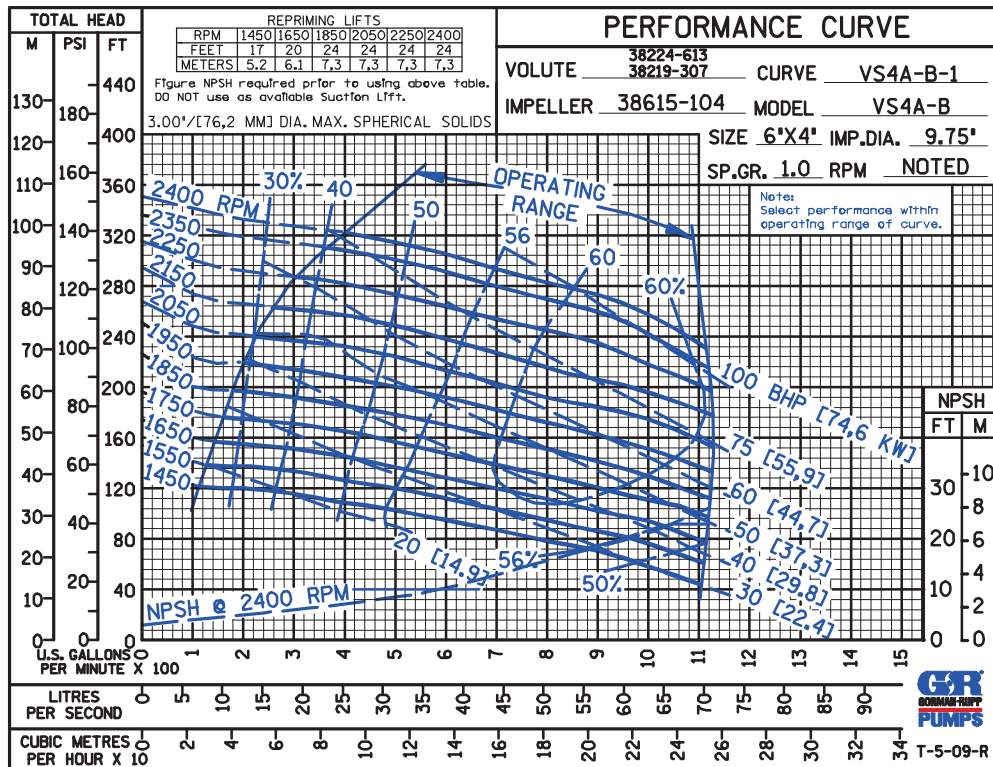

GORMAN-RUPP PUMPS

www.grpumps.com

Specifications Subject to Change Without Notice

Printed in U.S.A.

TOTAL
COMBINED
H.P. SHOWN

PERFORMANCE
BASED ON
WATER

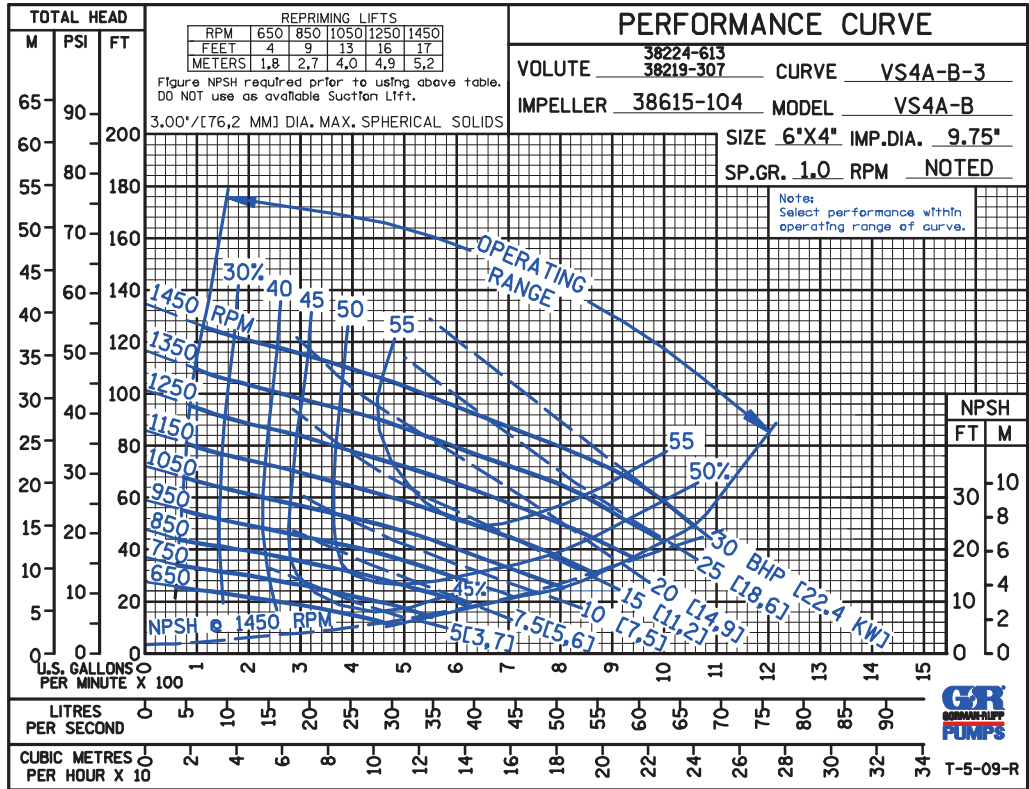

TOTAL
COMBINED
H.P. SHOWN

PERFORMANCE
FOR REDUCED
SUCTION
BASED ON
WATER

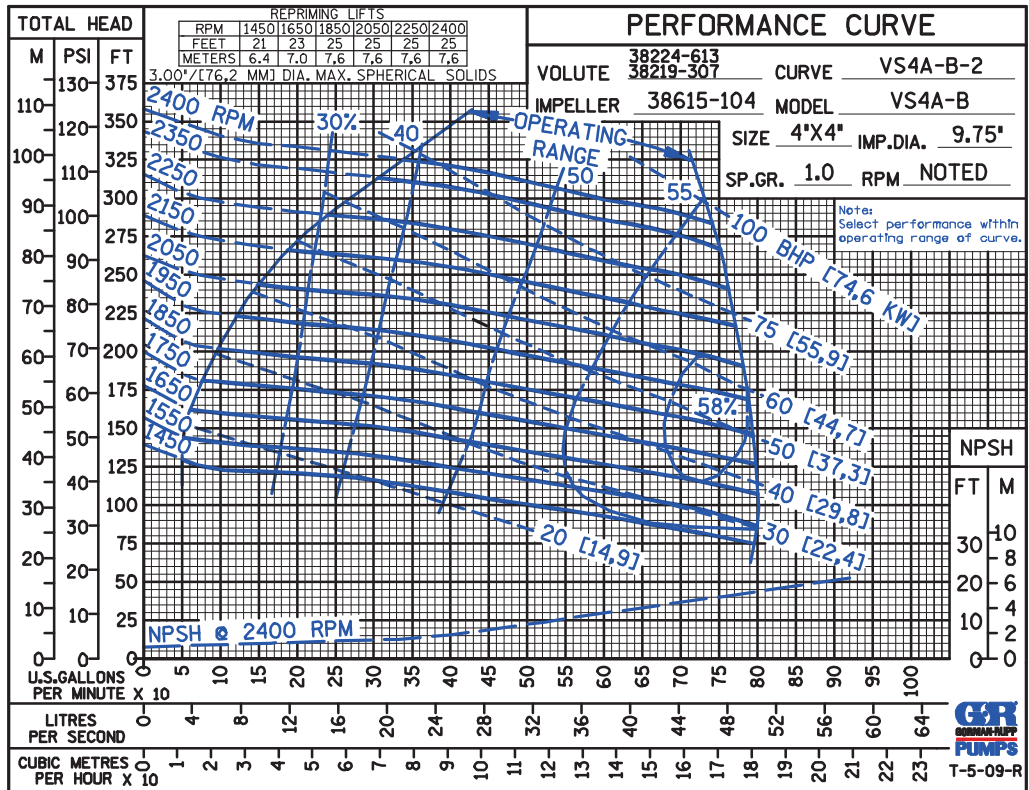

GORMAN-RUPP PUMPS

www.grpumps.com

Specifications Subject to Change Without Notice

Printed in U.S.A.

**TOTAL
COMBINED
H.P. SHOWN**

**PERFORMANCE
FOR REDUCED
SUCTION
BASED ON
WATER**

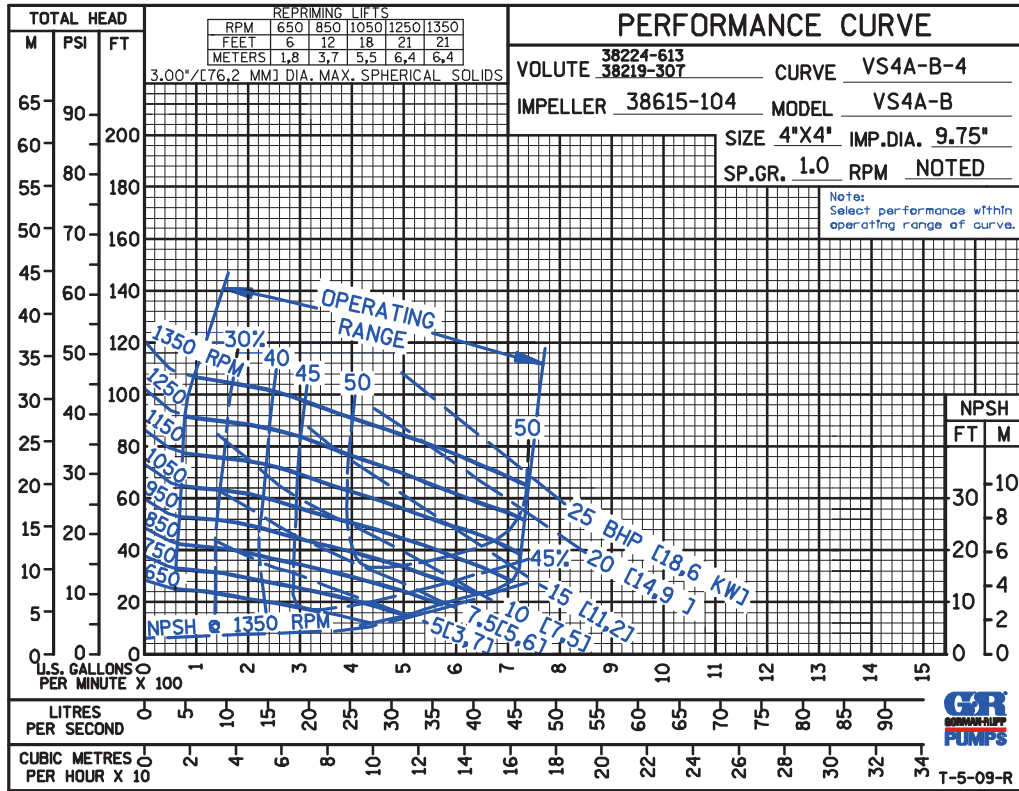

GORMAN-RUPP PUMPS

www.grpumps.com

Specifications Subject to Change Without Notice

Printed in U.S.A.