

# SERIES 1800 SCREENING/WASHING PLANT

## Model 1830P Spec Sheet

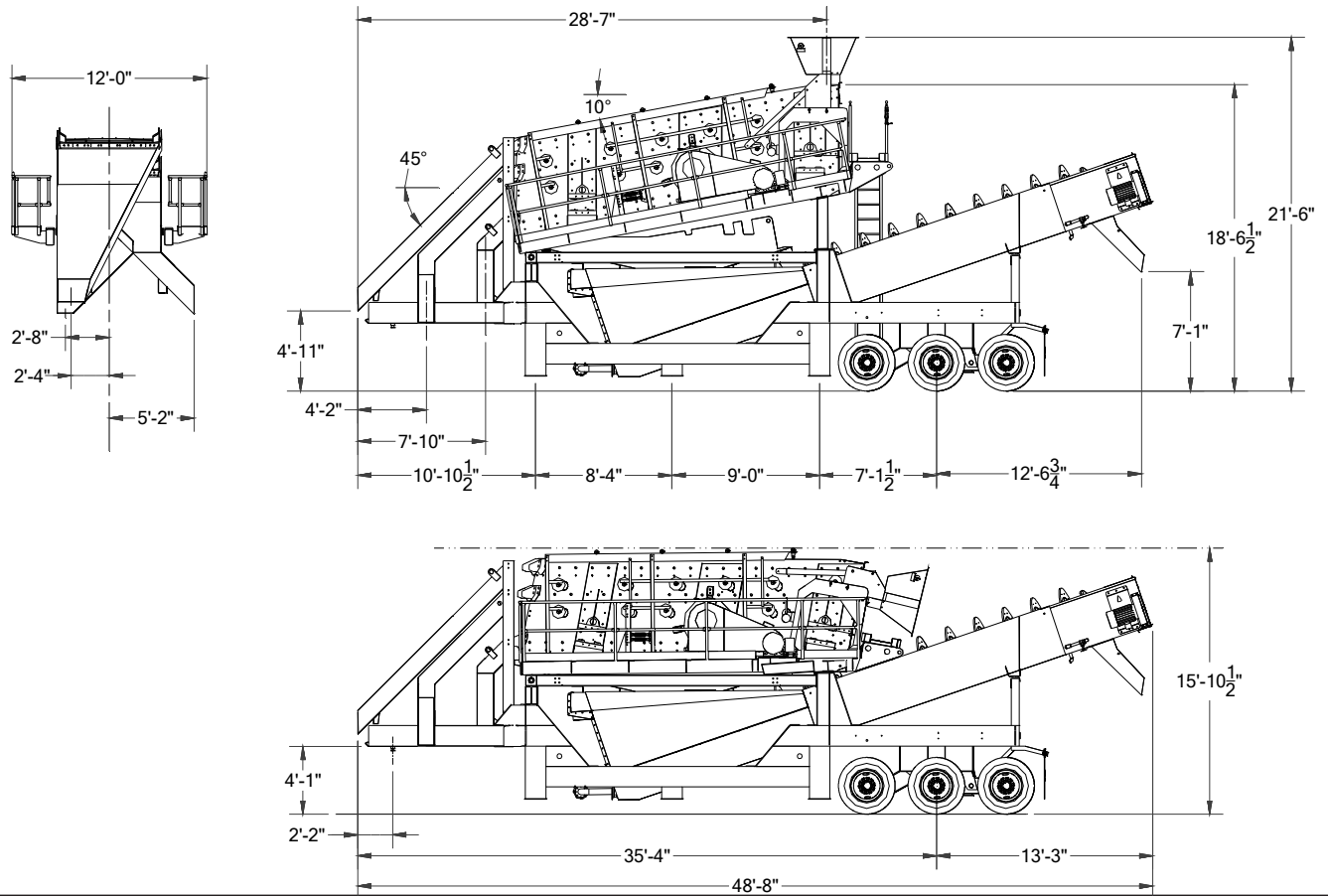

### ● SCREEN

- KPI-JCI 6' x 20', 3-deck, 10°, wet vibrating screen
  - V-belt drive assembly with 40-HP, 1800 RPM motor
  - Huck-bolted assembly
  - 3/8" plate steel side plates
  - Two (2) 160-mm bearings
  - Eccentric shaft with bolt-in counterweights
  - Eight (8) coil spring suspension system
  - Side tension drawbar screen cloth retention system (screen cloth is optional)
  - Screen operates at 10° angle with a shaft speed of approx. 900 rpm

### ● FINE MATERIAL WASHER

- KPI-JCI Model 5044-32T (44" twin) fine material washer
    - Tank is of 1/4" (sides and bottom) and 3/8" (rear end plate) welded plate steel construction and includes a curved bottom with integral rising current manifold (4" dia. inlet)
    - Large undisturbed pool area with adjustable weir boards and overflow flume with 12" dia outlet
    - Double pitch, solid flight spiral assembly with standard AR steel inner wear shoes and standard urethane outer wear shoes
    - Greaseable, externally mounted Dodge Imperial E tail end flange bearing; greaseable Dodge pillow block head end bearing
    - Lower end seal - chrome plated stainless steel wear sleeve, water tight bellows type rubber seal and secondary grease seal
    - High efficiency v-belt drive assembly (one drive assembly per spiral) includes 20-HP TEFC motor and Dodge TA-II double reduction shaft mount reducer
    - Tapered discharge chute set at 45° angle to grade
- See Model 5044-32T Spec Sheet for additional information

## ● CHASSIS

- Heavy duty 15" I-beam construction
- Equalizing walking beam axle arrangement with triple Dana 22,000# axles and twelve (12) 11:00 x 22.5 tires
- Fifth wheel king pin, air brakes, travel lights, mudflaps and cribbing locations

## ● WATER SYSTEM

- All fresh water plumbing to a single 6" inlet located near the tail end of the fine material washer
- Fine material washer manifold includes a 4" butterfly valve, 4" swing check valve and pressure gauge
- 1-1/2" chase water plumbing with gate valves
- Screen manifold with flow control valves for each spray bar
- Fourteen (14) spray bars with a total of one hundred ten (110) 7.0 gpm (@ 40 psi) spray nozzles and eighty-four (84) 15.0 gpm (@ 40 psi) spray nozzles
- 3" connection on the screen manifold for the optional feed box

## ● SCREEN CHUTES / FINES HOPPER

- 3/16" A36 welded plate steel construction
- Chutes allow for positioning of three (3) radial stackers under the chutes
- Fines hopper transitions to form the feed box and baffle plate of the 44" twin fine material washer

## ● ACCESS

- 24" wide access platform with 1-1/2" OD handrails and toeboards across the feed end of the screen
- 19" wide access platform with 1-1/2" OD handrails and toeboards along both sides of the screen
- Ladder access from grade which can be located on either side of the plant

## ● PHYSICAL / OPERATING CHARACTERISTICS

- Feed Material Size - Typically 6" minus
- Capacity - Approximately 700 TPH (dependent on feed gradation and desired products)
- Water Requirements - Up to 2,700 gpm (dependent on feed gradation and desired products)
- Travel Dimensions
  - Length 48'-8" overall / 33'-2" king pin to axle
  - Width 12'-0"
  - Height 15'-10"
- Operating Dimensions
  - Length 48'-8" overall
  - Width 12'-10-1/2"
  - Height 18'-6-1/2" without feed box / 21'-6" with feedbox
- Loads
  - King Pin 19,500 lbs
  - Axle 55,700 lbs
  - Overall 75,200 lbs
- Second Load (sand screw flares, etc) 5,000 lbs  
Note individual plant weights will vary dependent on options included

## ● OPTIONAL EQUIPMENT

- AR or urethane chute and hopper wear liners
- Fold-down feed box with winch and header pipes
- Wire mesh or urethane screen media
- Electrical package
- Blending gates
- Landing gear
- Hydraulic run-on jacks with electric or gas power pack
- Swing-away top and middle deck overs chutes
- Cross conveyors
- Remote grease package
- Hydraulic screen adjust
- Flare mounting in the king pin area
- Hinged/folding flares
- 36"T fine material washer vs 44"T

**FOR MORE INFORMATION CALL 1-800-542-9311 AND ASK FOR A KOLBERG EQUIPMENT SPECIALIST**

**NOTE:** Specifications are subject to change without notice.

Because KPI-JCI may use in its catalog & literature, field photographs of its products which may have been modified by the owners, products furnished by KPI-JCI may not necessarily be as illustrated therein. Also continuous design progress makes it necessary that specifications be subject to change without notice. All sales of the products of KPI-JCI are subject to the provisions of its standard warranty. KPI-JCI does not warrant or represent that its products meet any federal, state, or local statutes, codes, ordinances, rules, standards or other regulations, including OSHA and MSHA, covering safety, pollution, electrical wiring, etc. Compliance with these statutes and regulations is the responsibility of the user and will be dependent upon the area and the use to which the product is put by the user. In some photographs, guards may have been removed for illustrative purposes only. This equipment should not be operated without all guards attached in their normal position. Placement of guards and other safety equipment is often dependent upon the area and how the product is used. A safety study should be made by the user of the application, and, if required additional guards, warning signs and other safety devices should be installed by the user, wherever appropriate before operating the products.



700 W 21st. St., Yankton, SD 57078  
1-800-542-9311 Fax: 605-665-8858

Email: [mail@kpijci.com](mailto:mail@kpijci.com)  
[www.kpijci.com](http://www.kpijci.com)  
Mdl 1830P Rev. 3, 08/09