

# SERIES 5000 FINE MATERIAL WASHER

## Model 5054-34S Spec Sheet

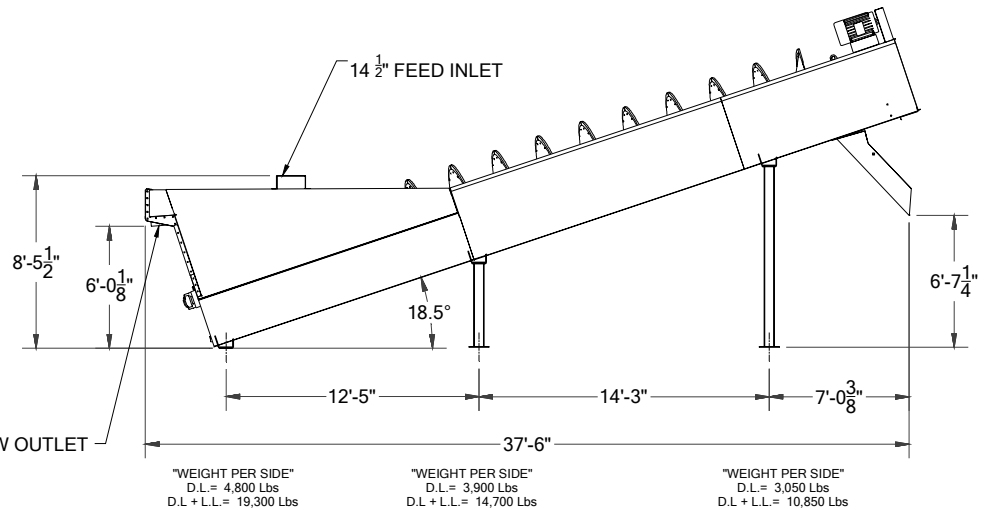
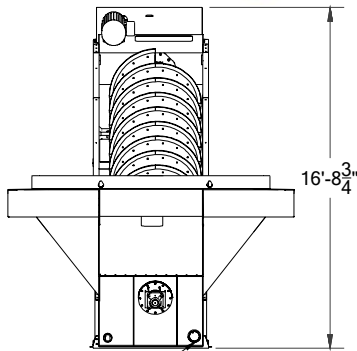
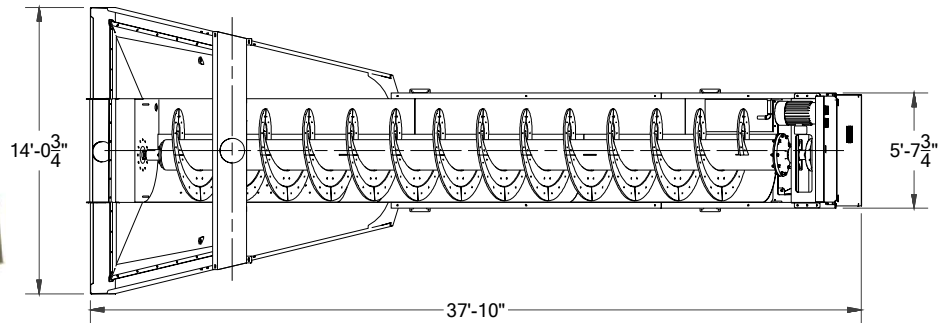
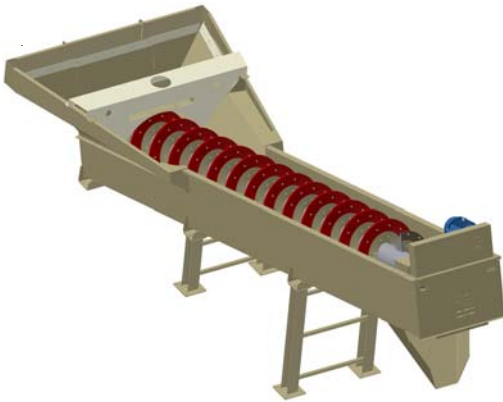

### ● MAIN TANK

- 1/4" (sides & bottom) and 3/8" (rear end plate) welded plate steel construction
- Curved bottom with integral rising current manifold (6" dia. inlet)
- Large undisturbed pool area
- 26' of adjustable weir boards
- 1-1/2" chase water line connection
- Overflow flume with 12" dia. outlet
- 4" dia. tank drain

### ● SPIRAL ASSEMBLY

- Spiral pipe - heavy wall 18" dia.
- Double pitch, solid flight spiral
- Standard AR steel inner wear shoes
- Standard urethane outer wear shoes (cast Ni-Hard outer wear shoes are optional)
- Greaseable, externally mounted Dodge Imperial E tail end flange bearing
- Greaseable Dodge Type E pillow block head end bearing
- Lower end seal - chrome plated stainless steel wear sleeve, water tight bellows type rubber seal and secondary grease seal

### ● DRIVE ASSEMBLY

- High efficiency v-belt drive assembly
- TEFC motor, HP dependent upon spiral speed - see "Raking & Overflow Capacity Table"
- Dodge TA-II double reduction shaft mount reducer

### ● CENTER FEED BOX

- 14-1/2" dia feed inlet
- Internally and externally baffled

### ● DISCHARGE CHUTE (optional)

- Tapered discharge chute set at 45° angle to grade

### ● SUPPORT ASSEMBLY (optional)

- Independent mid and head end support weldments with 6" wide flange columns

### ● RISING CURRENT ACCESSORIES (optional)

- Externally mounted manifold with 6" butterfly flow control valve, 6" swing check valve, 0-100 psi pressure gauge and 1-1/2" gate valve and plumbing to the chase water connection

● **PHYSICAL/OPERATING CHARACTERISTICS**

- Feed Material Size - minus 3/8"
- Angle of Operation - 18.5°
- Capacity - up to 250 tph
- Shaft Speed - up to 14 rpm
- Water Requirements - up to 1800 gpm
- Operational Dim. 37'10" long x 14'1" wide x 16'9" high
- Loads - Approx. Dead Load = 23,500 lbs.  
           Approx. Live Load = 66,200 lbs.  
           Approx. Total Load = 89,700 lbs.

**RAKING & OVERFLOW CAPACITY TABLE**

| CAPACITY<br>(TPH) | % SCREW<br>SPEED<br>(RPM) | SPIRAL<br>SPEED<br>(RPM) | MINIMUM<br>MOTOR HP<br>(REQ'D) | OVERFLOW CAPACITIES<br>(GPM) |          |          |
|-------------------|---------------------------|--------------------------|--------------------------------|------------------------------|----------|----------|
|                   |                           |                          |                                | 100 MESH                     | 150 MESH | 200 MESH |
| 250               | 100%                      | 14                       | 30                             |                              |          |          |
| 185               | 75%                       | 11                       | 25                             | 1800                         | 900      | 525      |
| 125               | 50%                       | 7                        | 15                             |                              |          |          |
| 60                | 25%                       | 4                        | 10                             |                              |          |          |

**PERCENT SCREW SPEED VS. PERCENT FINES IN PRODUCT**

| % SCREW SPEED<br>(RPM) | % PASSING<br>50 MESH | % PASSING<br>100 MESH | % PASSING<br>200 MESH |
|------------------------|----------------------|-----------------------|-----------------------|
| 100%                   | 15                   | 2                     | 0                     |
| 75%                    | 20                   | 5                     | 0                     |
| 50%                    | 30                   | 10                    | 3                     |
| 25%                    | 50                   | 25                    | 8                     |

**NOTE:** Specifications are subject to change without notice.

Because KPI-JCI may use in its catalog & literature, field photographs of its products which may have been modified by the owners, products furnished by KPI-JCI may not necessarily be as illustrated therein. Also continuous design progress makes it necessary that specifications be subject to change without notice. All sales of the products of KPI-JCI are subject to the provisions of its standard warranty. KPI-JCI does not warrant or represent that its products meet any federal, state, or local statutes, codes, ordinances, rules, standards or other regulations, including OSHA and MSHA, covering safety, pollution, electrical wiring, etc. Compliance with these statutes and regulations is the responsibility of the user and will be dependent upon the area and the use to which the product is put by the user. In some photographs, guards may have been removed for illustrative purposes only. This equipment should not be operated without all guards attached in their normal position. Placement of guards and other safety equipment is often dependent upon the area and how the product is used. A safety study should be made by the user of the application, and, if required additional guards, warning signs and other safety devices should be installed by the user, wherever appropriate before operating the products.



700 W 21st. St., Yankton, SD 57078  
 1-800-542-9311 Fax: 605-665-8858

Email: mail@kpijci.com  
 www.kpijci.com

Mdl 5054-34S Rev.3 07/13