

HORIZONTAL SHAFT IMPACTOR

Model 5260 Spec Sheet

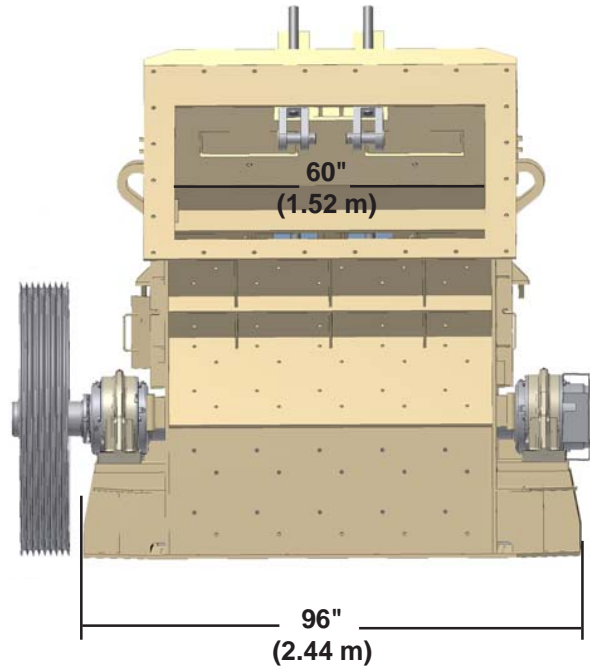
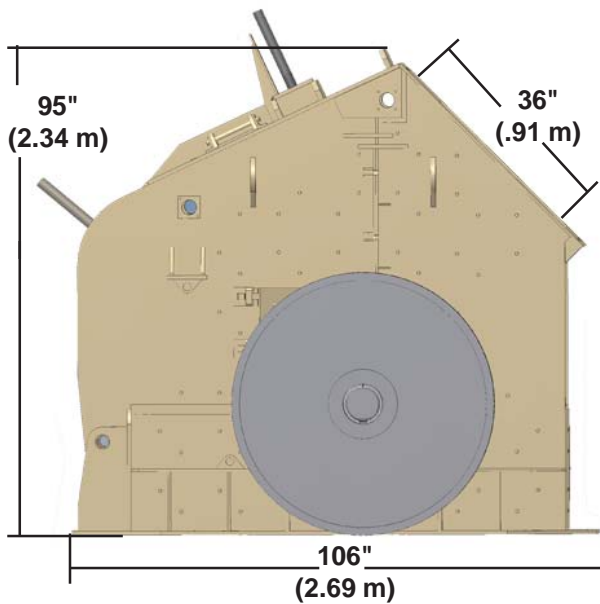

- **SHAFT**

- SAE4150 steel shaft

- **BEARINGS**

- Self-aligning spherical roller bearing (190mm)

- **ROTOR**

- 3 bar solid rotor design (optional 4 bar segmented rotor)
- Stress relieved

- **IMPACT BARS**

- Multiple chemistries available (950 lbs each)

- **CRUSHER HOUSING**

- Fabricated 3/4" plate
- Stress relieved
- Rear section opens for easy access

- **PRIMARY APRON**

- Fabricated 4" Hardox abrasive resistant steel
- Adjustable for gradation control
- Replaceable wear tips

- **SECONDARY APRON**

- Fabricated 4" Hardox abrasive resistant steel
- Adjustable for gradation control
- Replaceable wear tips

- **ADJUSTMENT**

- Screw type on primary hydraulic on secondary for easy setting of crusher

- **CHAMBER LINERS**

- 1-1/4" AR abrasive resistant steel
- 500 Bhn cast steel liners

- **LUBRICATION**

- Grease system

● **CRUSHER DATA**

HSI Feed Opening.....36" H x 60" W (914mm x 1523mm)
 Rotor Dimensions...52" Dia x 60" W (1320mm x 1523mm)
 Weight.....39,000 (17,691 kg)
 RPM.....330-600
 FPM.....4000-8000

Recommended HP.....300-400 Electric, 600 Diesel
 Approx. Capacities*.....300-450 tph
 Maximum Feed Size
 36" x 36" x 12" Recycle
 18" - 21" 4 Bar
 21" - 24" 3 Bar Limestone (10"-12" sec)
 15" - 18" 4 Bar
 18" - 21" 3 Bar Hard Rock (8"-10" sec)
 Minimum Apron Setting Primary 2"
 Secondary 1"

* Capacity depends on feed size and gradation, type of material, etc.

Horizontal Shaft Impact Crusher Gradations
 Gradation Control Based on Rotor Tip Speed

Andreas - 4230, 4233, 4240, 4250, 5260-3, 5260-4						
Feed	Limestone		Hard Rock		Rubble	
Gap	4 & 2		3 1/2 x 1 1/2		4 & 2	
Speed	6500	5000	6500	5000	6500	5000
Sieve Size						
3"		100				100
2 1/2"		96		100	100	93
2"	100	93	100	95	93	86
1 1/2"	96	90	94	88	85	80
1 1/4"	90	81	88	80	77	70
1"	85	72	83	72	70	60
7/8"	79	62	77	63	63	55
3/4"	73	53	71	54	55	50
5/8"	63	45	64	49	47	43
1/2"	54	38	57	45	40	35
3/8"	44	31	46	38	35	30
1/4"	35	25	36	30	30	25
#4	28	21	32	24	25	20
#8	20	15	23	18	20	15
#16	15	11	17	14	15	10
#30	12	8	12	9	10	5
#50	9	7	10	7	5	2
#100	7	6	8	5	3	1
#200	4	3	5	3	2	0.3

NOTE: Specifications are subject to change without notice.

Because KPI-JCI may use in its catalog & literature, field photographs of its products which may have been modified by the owners, products furnished by KPI-JCI may not necessarily be as illustrated therein. Also continuous design progress makes it necessary that specifications be subject to change without notice. All sales of the products of KPI-JCI are subject to the provisions of its standard warranty. KPI-JCI does not warrant or represent that its products meet any federal, state, or local statutes, codes, ordinances, rules, standards or other regulations, including OSHA and MSHA, covering safety, pollution, electrical wiring, etc. Compliance with these statutes and regulations is the responsibility of the user and will be dependent upon the area and the use to which the product is put by the user. In some photographs, guards may have been removed for illustrative purposes only. This equipment should not be operated without all guards attached in their normal position. Placement of guards and other safety equipment is often dependent upon the area and how the product is used. A safety study should be made by the user of the application, and, if required additional guards, warning signs and other safety devices should be installed by the user, wherever appropriate before operating the products.