

SERIES 7000 CLASSIFYING TANK

Model 7110-40P44T Spec Sheet

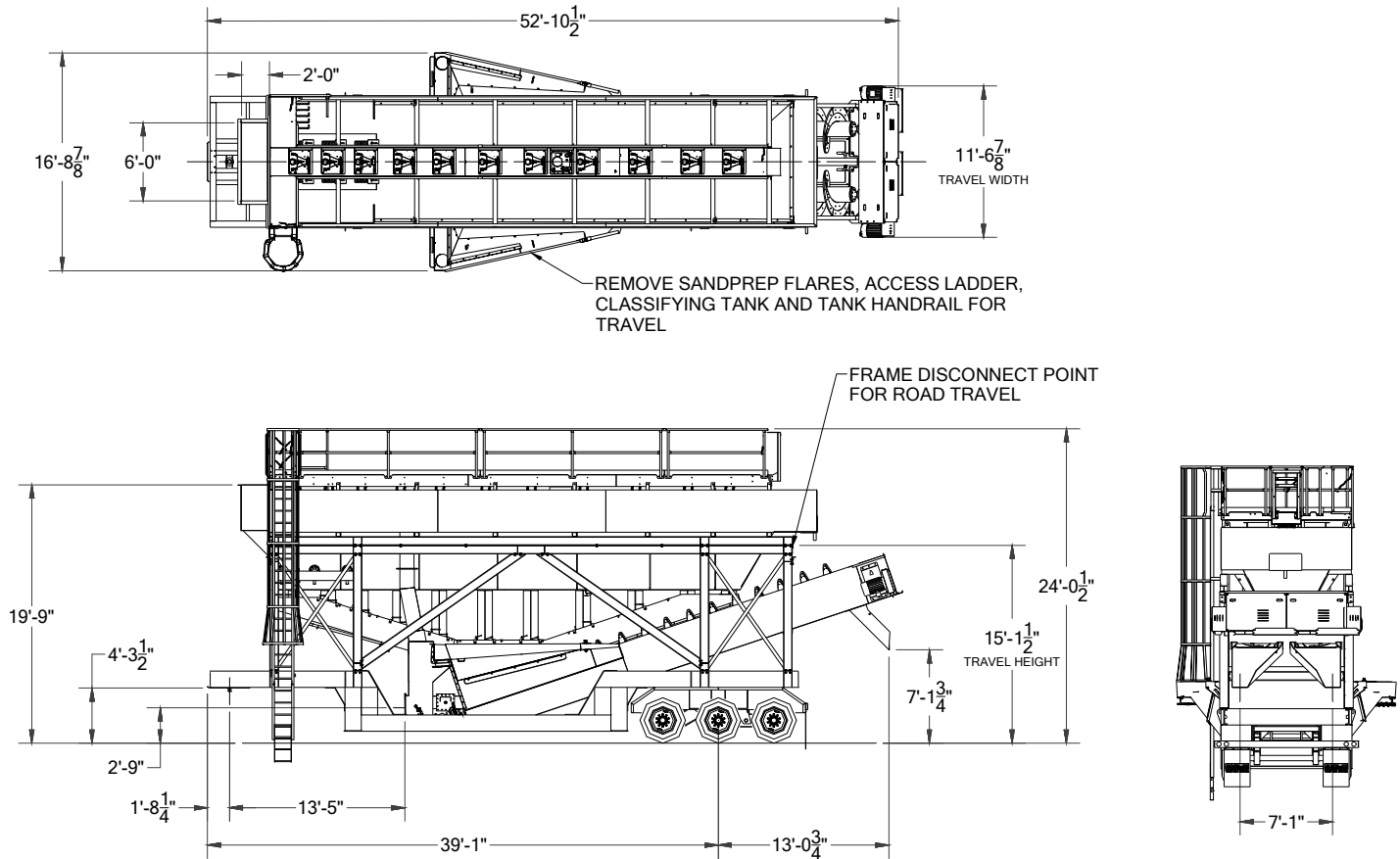

MODEL #7110-40 CLASSIFYING TANK

• MAIN TANK & COLLECTING FLUME

- Main tank - 1/4" (sides, ends, overflow launder & feed box) and 3/8" (bottom plate) welded plate steel construction
- Integral feed box with 1/4" AR curved liner and nominal 2' x 6' feed opening
- 74' of adjustable weir boards
- Integral overflow launder with dual discharge outlets
- Ladder rungs located near the feed end of the tank for internal tank access
- Self-support tank design with external stiffeners only - no internal stiffeners
- Three-cell collecting flume - 3/16" welded plate construction (unlined)

• WALKWAY & MECHANISM SUPPORT

- 24" wide diamond deck walkway across the feed end and down the center of the tank
- 1-1/2" O.D. posts, top and intermediate handrails
- 4" toeboards
- Removable/hinged door sections at each station
- Walkway support structure also houses and supports the electric/hydraulic operating mechanism

• VALVES, VALVE SEATS, DOWNPIPES & DISCHARGE ELBOWS

- Self-aligning urethane dart valves
- "Snap-in" urethane valve seats
- 6" schedule 40 UV rated PVC downpipes
- Urethane discharge elbows with rectangular discharge

• OPERATING MECHANISM

- 3 HP electric/hydraulic power pack with nominal 3 micron filtration
- 750-psi (adjustable to 1,000-psi) hydraulic system
- 10-gal. hydraulic reservoir
- Accumulator
- Eleven (11) settling stations each including:
 - * One (1) 24-volt DC adjustable height sensing paddle assembly
 - * Three (3) discharge valves with adjustable down rods operated by hydraulic cylinders
 - * Hydraulic manifold block with cartridge valves and 24-volt DC coils
 - * Individual ball and check valves
 - * Stainless steel hydraulic plumbing with o-ring face seal fittings

Operating Mechanism continued on next page

● OPERATING MECHANISM

- All stations prewired to a bridge mounted NEMA 4 junction box which also houses the PLC (programmable logic controller)
- All wiring in the form of “plug and receptacle” type cords
- Controller: Standard Dell PC HMI (human-machine-interface) including CPU, monitor, keyboard, optical mouse and Windows™ based programming. An optional industrial PC HMI with touch screen housed in a NEMA 4 enclosure is available for outdoor installations

Note: See Model #7110-40 specification sheet for additional information

MODEL #5044-32T DEWATERING SCREW:

● MAIN TANK

- 1/4” (sides & bottom) and 3/8” (rear end plate) welded plate steel construction
- Curved bottom with integral rising current manifold (4” dia. inlets)
- Large undisturbed pool area
- 26’ of adjustable weir boards
- 1-1/2” chase water line connection
- Integral overflow flume

● SPIRAL ASSEMBLY

- Spiral pipe - heavy wall 14” dia.
- Double pitch, solid flight spiral (one right hand, one left hand)
- Standard AR steel inner wear shoes
- Standard urethane outer wear shoes (cast Ni-Hard outer wear shoes are optional)
- Greaseable, externally mounted Dodge Imperial E tail end flange bearing
- Greaseable Dodge Type E pillow block head end bearing
- Lower end seal - chrome plated stainless steel wear sleeve, water tight bellows type rubber seal and secondary grease seal

● DRIVE ASSEMBLY (one drive assembly per spiral)

- High efficiency v-belt drive assembly
- 20 HP TEFC motor
- Dodge TA-II double reduction shaft mount reducer

● DISCHARGE CHUTES

- Independent/reversible tapered discharge chutes set at 45° angle to grade

● RISING CURRENT ACCESSORIES

- Externally mounted manifold with 4” butterfly flow control valve, 4” swing check valve, 0-100 psi pressure gauge and 1” gate valve and plumbing to the chase water connection

Note: See Model #5044-32T specifications sheet for additional information

PLANT

● CHASSIS

- Main truck frame beams - 15” I-beam
- Fifth wheel king pin
- Triple walking-beam axle with dual 11:00 x 22.5 tires
- Air brakes
- Travel lights (stop, tail and turn)
- Mudflaps
- Cribbing locations
- Removeable ladder access to the bridge of the classifying tank

● PHYSICAL/OPERATING CHARACTERISTICS

- Feed Material Size - minus 3/8”
- Capacity - TPH dependent on water requirements for proper feed material dilution and desired material retention
- Water Requirements - up to 5,900 gpm
- Travel Dimensions - Plant 52’11” L x 11’7” W x 15’2” H
2nd Load 44’4” L x 10’3” W x 9’6” H
(typically shipped on a 48’ single drop step deck trailer)
- Operational Dimensions - 52’11” L x 16’9” W x 24’1” H
- Loads King Pin = 13,260 lbs.
Axle = 44,940 lbs.
Overall = 58,200 lbs.
Second Load = 27,750 lbs.

Note: Individual plant weights will vary dependent on options included

Note: The classifying tank must be removed for transport and shipped on a separate load

● OPTIONAL EQUIPMENT

- Three-cell rising current classifier (includes external manifold, individual flow control valves and internal baffling at the first three stations within the classifying tank)
- 8” flanged, pressure reducing/check valve
- Recirculating pump
- AR or urethane liners for the three-cell collecting flume
- Hinged/folding flares
- Model #7208-32P44T: KPI-JCI exclusive system monitoring components that monitor the mechanical, hydraulic and electrical functions of the classifying tank and alert the operator, both locally and remotely, of potentially failed components and/or operational conditions that are outside the normal operating parameters.

NOTE: Specifications are subject to change without notice.

Because KPI-JCI may use in its catalog & literature, field photographs of its products which may have been modified by the owners, products furnished by KPI-JCI may not necessarily be as illustrated therein. Also continuous design progress makes it necessary that specifications be subject to change without notice. All sales of the products of KPI-JCI are subject to the provisions of its standard warranty. KPI-JCI does not warrant or represent that its products meet any federal, state, or local statutes, codes, ordinances, rules, standards or other regulations, including OSHA and MSHA, covering safety, pollution, electrical wiring, etc. Compliance with these statutes and regulations is the responsibility of the user and will be dependent upon the area and the use to which the product is put by the user. In some photographs, guards may have been removed for illustrative purposes only. This equipment should not be operated without all guards attached in their normal position. Placement of guards and other safety equipment is often dependent upon the area and how the product is used. A safety study should be made by the user of the application, and, if required additional guards, warning signs and other safety devices should be installed by the user, wherever appropriate before operating the products.



700 W 21st. St., Yankton, SD 57078
1-800-542-9311 Fax: 605-665-8858

Email: mail@kpijci.com
www.kpijci.com

Mdl 7110-40P44T Rev.3 02/10