

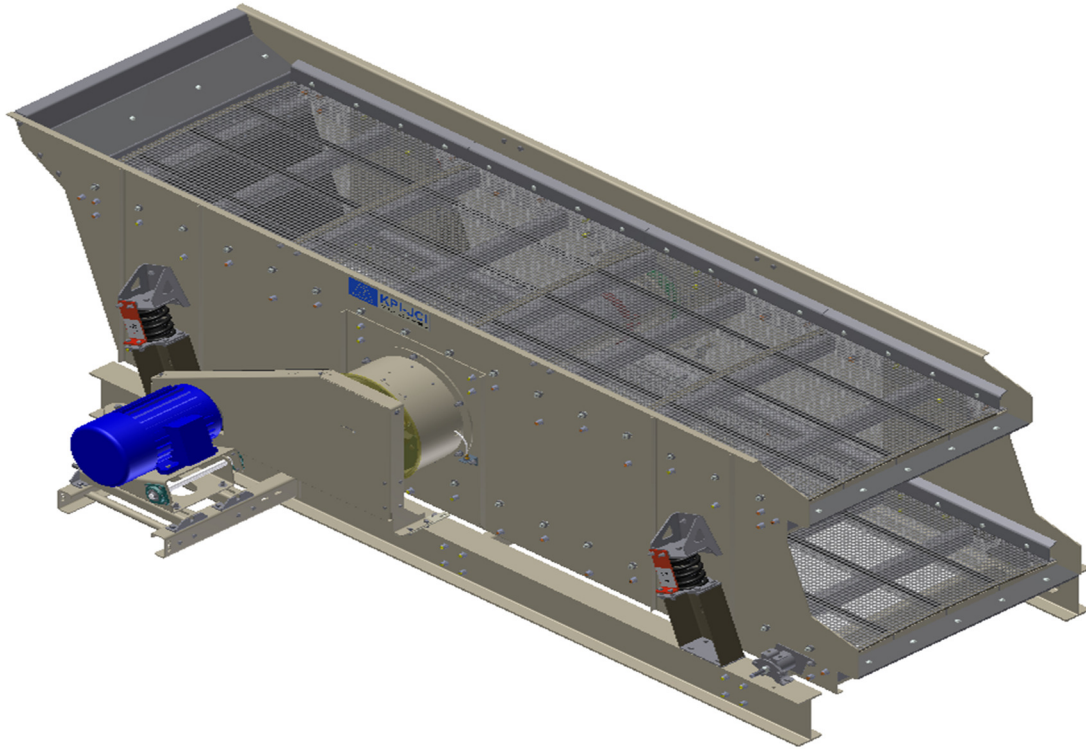

Standard Screen Specifications Single Incline Cascade Spec Sheet (SIC)



• SCREEN FEATURES

- Heavy duty 5/16" side plates & reinforcing plates
- Huck-bolted assembly
- Circular stroke pattern
- Incline angle 20 degrees
- Single crown top, ctr, & btm decks set up for wire cloth
- Changeable amplitude (stroke) - *completed by adding or removing bolt on weights, change driven sheave & hub*
- Standard stroke - 3/8" set to run at 850 rpm (optional 1200 rpm motor)
- Grease lubricated bearings
- Labyrinth seal & lip seal to prevent grease contamination
- Wire springs
- Rubber snubbers to minimize side to side movement and dampen screen motion on start-up and shut-down
- Bolt on rubber tailgates between decks
- 12" feedbox with 1/4" AR plate liner
- 6" discharge lip with 1/4" AR plate liner
- Heavy duty vibrating screen double roll bronze cage spherical roller bearings
- High strength long lasting 4' drawplates
- Vertical spring support channels for strong basket
- Jacking bolts for easy service of shaft assembly
- Heavy-duty 5/16" shaft tube guard
- Screen width nominal on 4', 5', and 6' screens
(Ex. 4' screen has 48" inside plate width)
- Right hand elec v-belt motor drive w/belt guard
- Pivoting motor base (motor optional)

OPTIONAL EQUIPMENT

- Base frame: parallel, horizontal, or stand type
- Access hole & covers for CTR deck drawplate bolts on 3 deck screens
- Spray pipe holes or knockouts
 - Spray system with stationary pipe supports
 - Spray pipes with threaded nozzles 1/4" orifice
 - Splash pipes with 1/8" opening
 - Urethane nozzles
- Screen width: nominal width +2" or +4" (for custom widths consult the factory)
Ex. 6' wide screen has optional 74" or 76"
- 1200 rpm TEFC motor
- Wire screen cloth
- Oil lubricated bearings
- Left-hand screen drive
- Incline angle: 10, 15 or 25 degrees
- Rubber Springs
- Urethane decks
- Special feedbox: 18" or 24"
- Paint colors

FEATURE	SPECIFICATION	FEATURE	SPECIFICATION
Standard Stroke Length	3/8"	Cloth support bar thickness (rail thickness)	3/8"
Standard operating speed	850 rpm	Deck cross-member spacing	24"
Optional stroke speed relationship	¼" stroke 1000 rpm ½" stroke 750 rpm	Side plate thickness	5/16"
Maximum feed size	10"	Reinforcing plate thickness	5/16"
Maximum media weight	8lbs/sq. ft. (Net of mounting hardware)	Feed box liner thickness (AR plate)	¼"
Maximum top deck opening	4"	Discharge lip liner thickness (AR plate)	¼"
Maximum drop of feed	18"	Shaft tube guard	5/16"

SCREEN DIMENSIONS

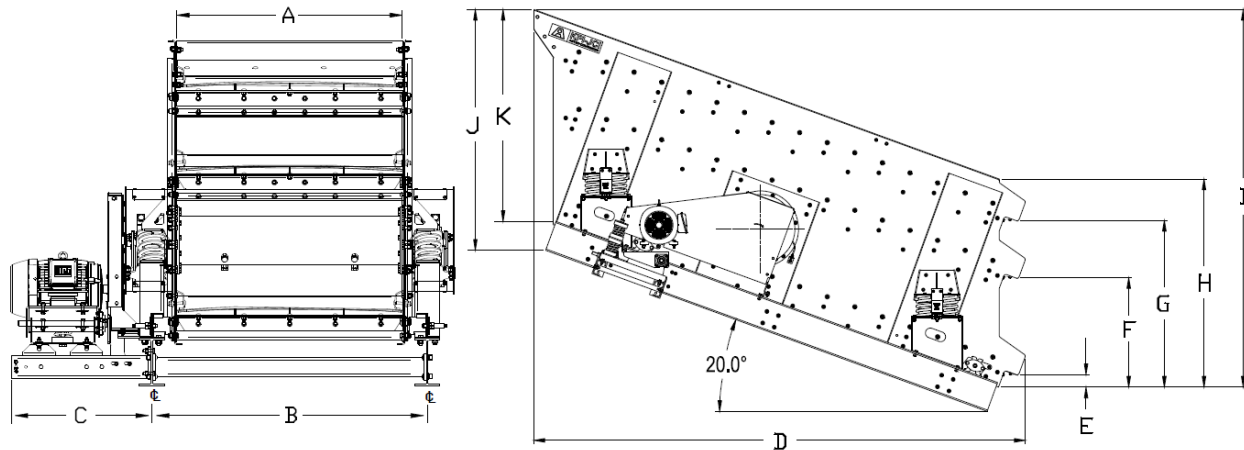

SCREEN SIZE	850 RPM (HP)	BASKET WEIGHT LBS/ (KG)	"A" IN (MM)	"B" IN (MM)	"C" IN (MM)	"D" IN (MM)	"E" IN (MM)	"F" IN (MM)	"G" IN (MM)	"H" IN (MM)	"I" IN (MM)	"J" IN (MM)	"K" IN (MM)
5162-26SIC 5162-32SIC	25	12000 (5445)	5' (1524)	6'-1/2" (1842)	3' 3-9/16" (1003)	16' 8-3/4" (5098)	5-1/16" (128)	3' 8-7/16" (1128)	N/A	5' 1-7/16" (1559)	10' 10-9/16" (7770)	6' 2-13/16" (1899)	5' 4-5/16" (1634)
5163-26SIC 5163-32SIC	25	12806 (5821)	5' (1524)	6'-1/2" (1842)	3' 3-9/16" (1003)	16' 8-3/4" (5098)	5-1/8" (130)	3' 8-5/8" (1133)	5' 8" (1728)	7' 13/16" (2155)	12' 10" (3912)	8' 2-3/16" (2494)	7' 2-7/16" (2196)
6162-26SIC 6162-32SIC	25	13000 (5900)	6' (1828)	7'-1/2" (2146)	3' 3-9/16" (1003)	16' 8-3/4" (5098)	5-1/16" (128)	3' 8-7/16" (1128)	N/A	5' 1-7/16" (1559)	10' 10-9/16" (7770)	6' 2-13/16" (1899)	5' 4-5/16" (1634)
6163-26SIC 6163-32SIC	25	16614 (7536)	6' (1828)	7'-1/2" (2146)	3' 3-15/16" (1013)	16' 8-3/4" (5098)	4-1/16" (123)	3' 8-7/16" (1128)	5' 7-13/16" (1723)	7' 13/16" (2155)	12' 10" (3912)	8' 2-3/16" (2494)	7' 3-3/4" (2229)
6202-32SIC	25	15750 (7145)	6' (1828)	7'-1/2" (2146)	3' 3" (990)	20' 5-7/8" (6244)	5-1/16" (128)	3' 8-7/16" (1128)	N/A	5' 1-7/16" (1559)	12' 3" (3733)	6' 2-13/16" (1899)	5' 4-5/16" (1634)
6203-32SIC	30	19850 (9000)	6' (1828)	7'-1/2" (2146)	3' 3" (990)	20' 5-7/8" (6244)	5-1/16" (128)	3' 8-7/16" (1128)	5' 7-13/16" (1723)	7' 13/16" (2155)	14' 2-7/16" (4329)	8' 2-3/16" (2494)	7' 3-3/4" (2229)

Note: Specifications are subject to change without notice.

Because KPI-JCI may use in its catalog & literature, field photographs of its products which may have been modified by the owners, products furnished by KPI-JCI may not necessarily be as illustrated therein. Also continuous design progress makes it necessary that specifications be subject to change without notice. All sales of the products of KPI-JCI are subject to the provisions of its standard warranty. KPI-JCI does not warrant or represent that its products meet any federal, state, or local statutes, codes, ordinances, rules, standards or other regulations, including OSHA and MSHA, covering safety, pollution, electrical wiring, etc. Compliance with these statutes and regulations is the responsibility of the user and will be dependent upon the area and the use to which the product is put by the user. In some photographs, guards may have been removed for illustrative purposes only. This equipment should not be operated without all guards attached in their normal position. Placement of guards and other safety equipment is often dependent upon the area and how the product is used. A safety study should be made by the user of the application, and, if required additional guards, warning signs and other safety devices should be installed by the user, wherever appropriate before operating the products.



86470 Franklin Blvd, Eugene, OR 97405
1-800-314-4656 Fax: 541-988-9401

Email: mail@icieug.com
www.kpijci.com

SIC Screens 3/13 Rev1