

# FOLD 'N GO<sup>®</sup>

Self Contained Track Plant | Superior Toughness | Unmatched Screen Capacity

## TRACK SCREENING PLANT



AGGREGATE AND  
MINING GROUP

All FAST TRAX high frequency screening plants feature the ultimate in screen production and efficiency. All FT track screening plants are designed for operation with track crushers in tight spots and comes with a double deck PEP Vari-Vibe<sup>®</sup> high frequency screen for a wide range of applications from crushed stone to RAP. As with all track screening plants offered by Astec Mobile Screens, the FT2618VM Fold 'n Go offers totally self contained diesel power with standard wireless remote for plant movement. This track screening plant provides the highest screen capacity in the market for material separation ranging from 1" to 30M.

# FT2618VM FOLD 'N GO

1" to 30M

Highest screen capacity in the market in this size range.

125 HP

Tier III John Deere water cooled diesel engine to power all plant functions.

6'X18'

PEP Vari-Vibe® 2618V double deck high frequency screen.

Up to 350 TPH

Screening plant can process up to 350 TPH or more of feed material.

## PERFORMANCE

- P1** **PEP Vari-Vibe® 2618V**  
This modified double deck high frequency screen: 6' x 18' top deck and 6' x 12' bottom deck for improved screen production.

## DURABILITY

- D1** **Stealth Tappet Design**  
Redesign of this component makes the vibrators more durable.

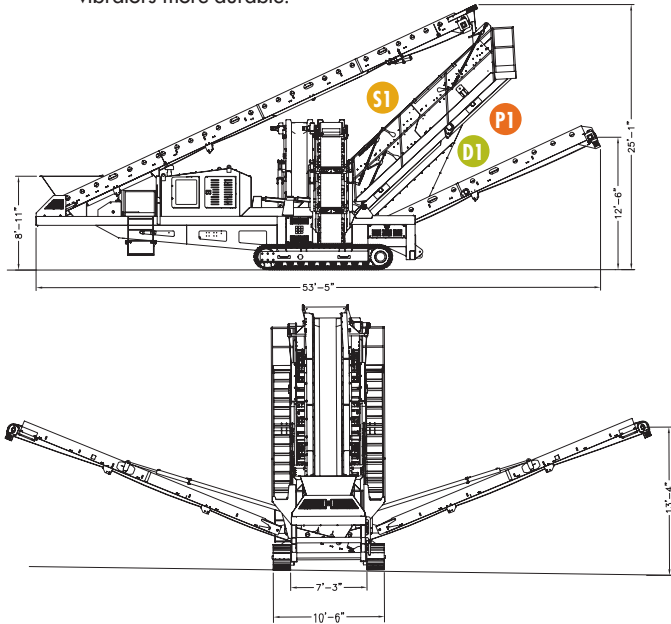

## SAFETY

- S1** **Dust Cover**  
The vinyl dust cover provides dust control and cleaner air in the work area.

## EASE-OF-USE

- E1** **Fast Setup**  
Quick setup times give producers more time to produce material.
- E2** **Central Grease Points**  
Makes routine services easy.

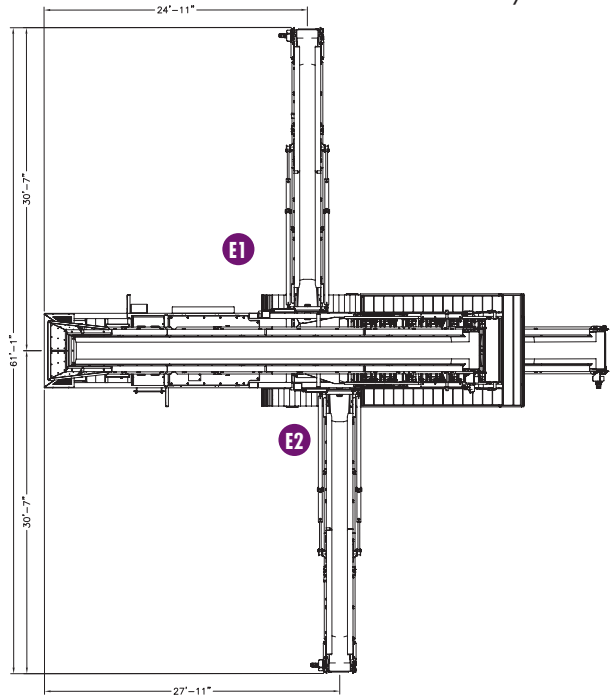

### STEALTH TAPPETS

Redesigned variable speed hydraulic vibrator tappets produce less sticking of material and better wear. Fourteen tappets are mounted below the screens for directly induced vibrating action.



### HIGH FREQUENCY SCREEN

A double deck PEP Vari-Vibe® high frequency screen with hydraulic screen angle adjustment and rotary screen tensioning system can meet different aggregate application demands with ease.



### SUPERIOR FINES REMOVAL

The PEP screen is unmatched in the industry for fines removal, especially in the 1/2" minus range in a wide range of applications, from crushed stone to RAP.

[www.kpijci.com](http://www.kpijci.com)

## PART OF THE FAST TRAX FAMILY OF EQUIPMENT.

Designed to run with the KPI-JCI family of tracked impactors to produce high capacities of saleable products.

## SERVICE MADE EASY

Because we're dedicated to keeping you up and running, we've provided two resources for quality O.E.M. parts and 24/7 service. Astec Mobile Screens and KPI-JCI parts and service are available from your local dealer and/or representative.

**Find the dealer or representative nearest you at [www.kpijci.com](http://www.kpijci.com).**

Because Astec Mobile Screens may use in its catalog & literature, field photographs of its products which may have been modified by the owners, products furnished by Astec Mobile Screens may not necessarily be as illustrated therein. Also continuous design progress makes it necessary that specifications be subject to change without notice. All sales of the products of Astec Mobile Screens are subject to the provisions of its standard warranty. Astec Mobile Screens does not warrant or represent that its products meet any federal, state, or local statutes, codes, ordinances, rules, standards or other regulations, including OSHA and MSHAGATOR, covering safety pollution, electrical, wiring, etc. Compliance with these statutes and regulations is the responsibility of the user and will be dependent upon the area and the use to which the product is put by the user. In some photographs, guards may have been removed for illustrative purposes only. This equipment should not be operated without all guards attached in their normal position. Placement of guards and other safety equipment is often dependent upon the area and the use to which the product is put. A safety study should be made by the user of the application, and, if required, additional guards, warning signs and other safety devices should be installed by the user, wherever appropriate before operating the products.

NOTE: SPECIFICATIONS ARE SUBJECT TO CHANGE WITHOUT NOTICE

REV. 2/28/2011