

Operational Mode

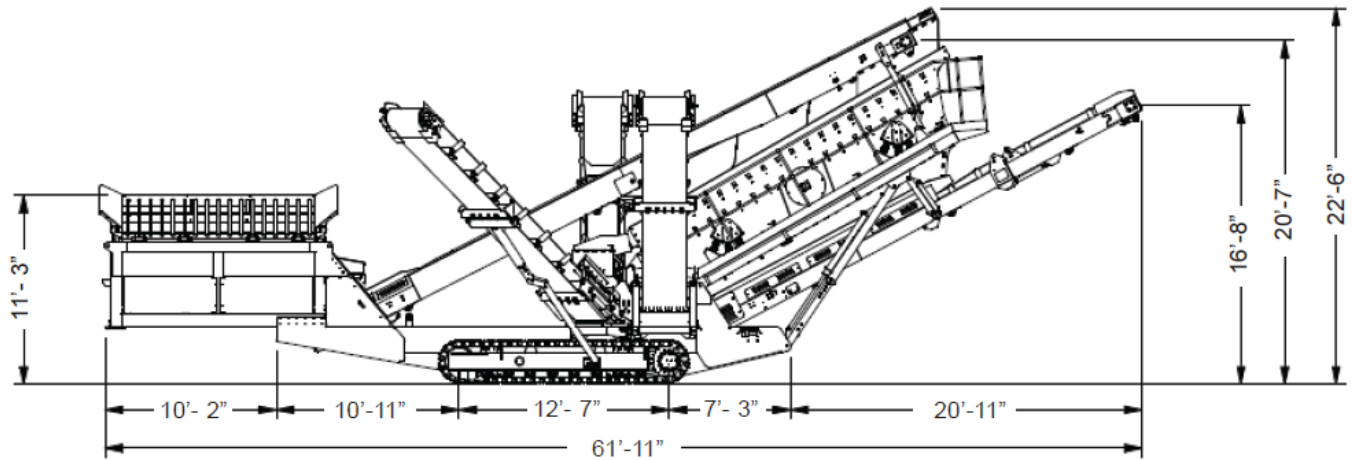

Transport Mode

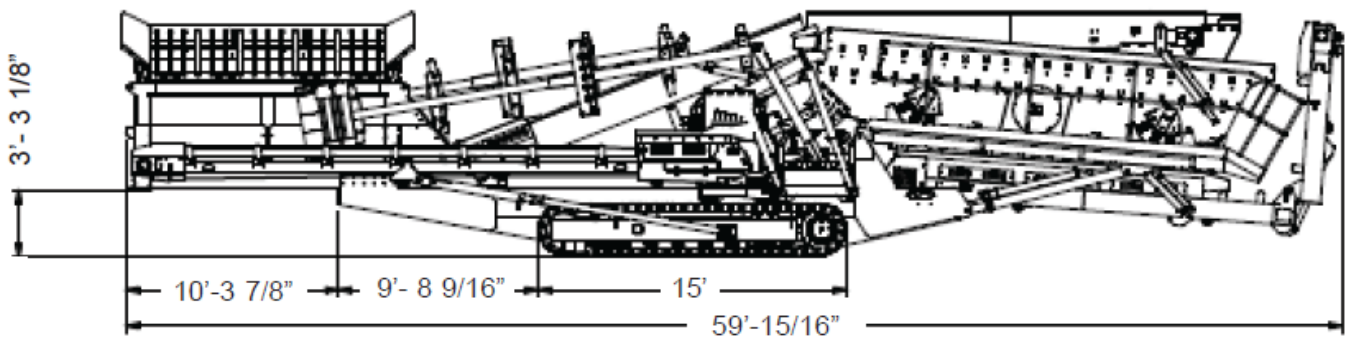

HOPPER

- 10 cubic yard capacity
- Heavy duty sloped grizzly with 6" openings
- Hydraulic remote tipping grid and wings
- Hydraulic support legs

FEEDER

- 13'-0" x 1200mm belt feeder
- Hydraulic variable speed drive

DELIVERY CONVEYOR

- 36'-0" x 1050mm conveyor, hydraulic drive
- Full-length skirt boards
- Chevron Belt, Vulcanized

VIBRATING SCREEN

- 5' x 20' top, 18' bottom deck
(5' x 20' middle deck on 3 deck option)
- 950 RPM adjustable amplitude
- Hydraulic angle adjustment
- Access ladder with wrap around walkway

OVERS CONVEYOR (3 Deck)

- 30'-0" x 650mm conveyor, swing out design
- Hydraulic variable speed drive
- Chevron Belts, Vulcanized

PRODUCT CONVEYORS

- Two (2) 28'-0" x 800mm conveyor, swing out design
- Hydraulic variable speed drive
- Chevron Belts, Vulcanized

NOTE: Specifications are subject to change without notice.

FINES CONVEYOR

- 24'-0" x 1200mm, conveyor, hydraulic drive

- Vulcanize

CHASSIS

- 18" channel frame
- Tracks
- Pendant remote control (wireless optional)

POWER & HYDRAULICS

- Cat 129 HP Tier III diesel engine
- 120 gallon fuel tank
- Oil Cooler
- Hydraulic pumps operate all plant functions
- 130 gallon hydraulic reservoir
- NEMA-4 rated instrument panel
- Emergency stops

Paint

- One primer coat, finish coat of KPI beige

Plant Capacity

- Up to 600 TPH (tonnages will vary with conditions)

OPTIONS

- Standard Steel Screen Cloth
- Ball Tray for Bottom Deck Module
- Hammermill Shredder
- 15' Hopper Feeder in lieu of 12' Hopper Feeder
- 2-deck Vibrating Screen Configuration
- Tier IV Engine
- Rinser Package: includes Spray Bars and Collection Flume (ILO Fines Conveyor)
- Rinser Package plus Fines Conveyor Package (Rinser Package or Fines Conveyor System must be determined at time of order for installation. The package not chosen for installation will be shipped on a separate load.)
- Consult Factory for Additional Options

APPLICATION PARAMETERS

- Maximum Feed to Grizzly.....24"/730mm
- Maximum Top Deck Screen Opening.....4"/102mm
- Grizzly Spacing.....6"/152mm
- Maximum Total Products.....(3) sized, 1 oversize

PHYSICAL OPERATING CHARACTERISTICS

- Overall Length.....61'11"/18.87m
- Travel Length.....60'/18.29m
- Operating Height.....22'6"/6.86m
- Travel Height.....11'10"/3.61m
- Operating Width.....59'9"/18.26m
- Travel Width.....11'2"/3.41m
- Feed Height11'3"/3.43m
- Unit Weight.....82,800 lbs/37,558kg

OPERATING SLOPE

- Side to Side.....1% grade
- Front to Back.....3% grade



2704 West LeFevre Road
Sterling, IL 61081

Phone: (815) 626-6374

FAX: (815) 626-6430

mail@kpijci.com

www.kpijci.com

NOTE: Specifications are subject to change without notice.

Because Astec Mobile Screens may use in its catalog & literature, field photographs of its products which may have been modified by the owners, products furnished by Astec Mobile Screens may not necessarily be as illustrated therein. Also continuous design progress makes it necessary that specifications be subject to change without notice. All sales of the products of Astec Mobile Screens are subject to the provisions of its standard warranty. Astec Mobile Screens does not warrant or represent that its product meet and federal, state, or local statutes, codes, ordinances, rules, standards or other regulations, including OSHA and MSHA, covering safety, pollution, electrical wiring, etc. Compliance with these statutes and regulations is the responsibility of the user and will be dependent upon the areas and the use to which the product is put by the user. In some photographs, guards may have been removed for illustrative purposes only. This equipment should not be operated without all guards attached in their normal position. Placement of guards and other safety equipment is often dependent upon the area and the use to which the product is put. A safety study should be made by the user of the application, and, if required additional guards, warning signs and other safety devices should be installed by the user, wherever appropriate before operating the products.