

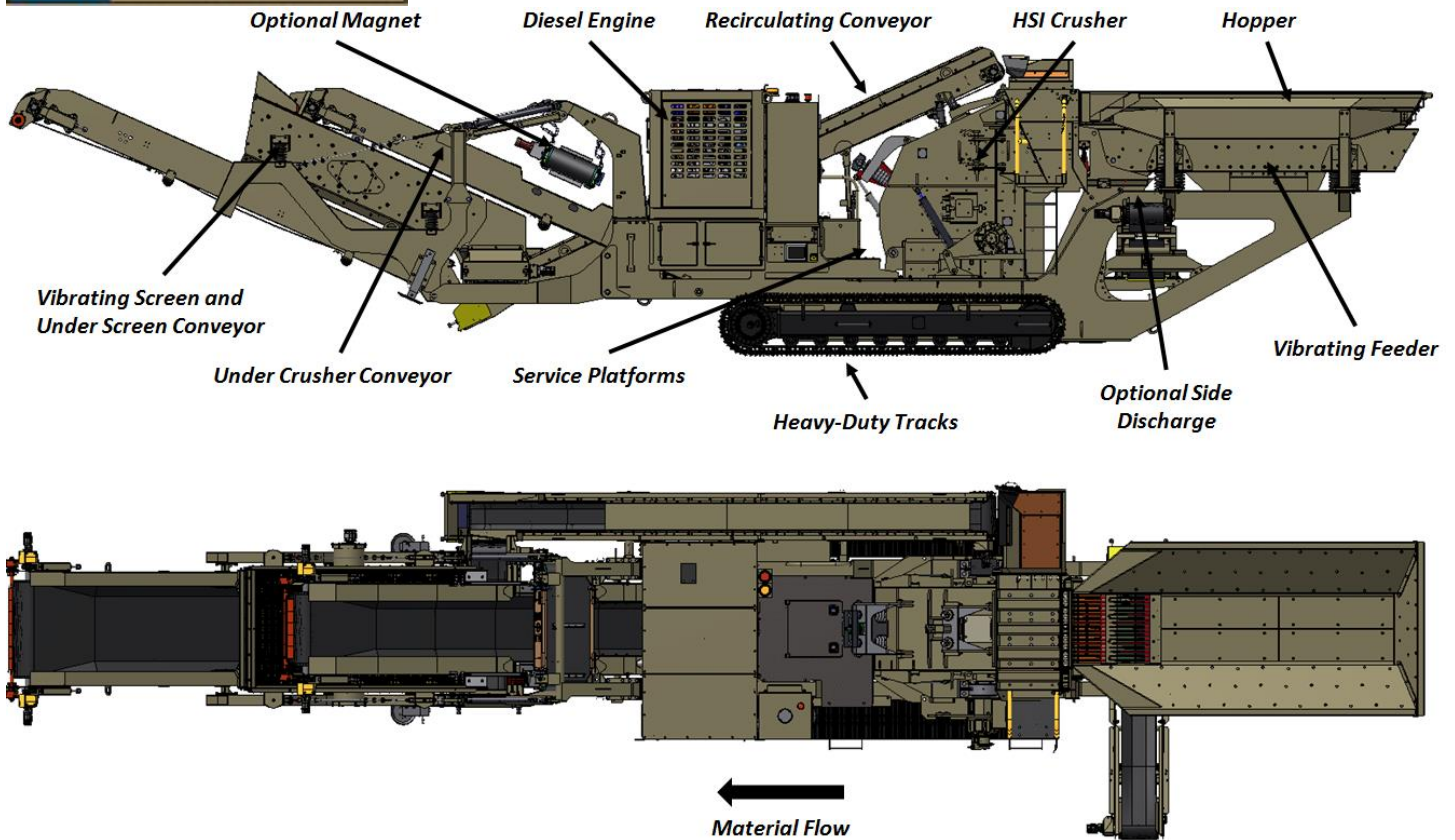

# GT440 TRACK-MOUNTED CRUSHING PLANT CLOSED CIRCUIT



- VIBRATING GRIZZLY FEEDER**
  - 40" (1016mm) x 14' (4.3m) Vibrating Pan Feeder
  - Hopper with fixed walls
  - 43" step-deck grizzly bars 1" nominal spacing
  - Bypass chute with flop gate and AR liner
- IMPACT CRUSHER – ANDREAS HSI**
  - HSI opening- 36" (914mm) HSI width- 40" (1016mm)
  - Self-aligning spherical roller bearing
  - 3-bar MPR rotor
  - Multiple blow bar chemistries available to fit application
  - Hydraulic adjust aprons
  - Hydraulically actuated rear access
- UNDER CRUSHER CONVEYOR**
  - 36" (900mm) fixed height with full spill boards
  - Impact bed, 360 PIW, endless belting
  - Easily removed for maintenance
- SCREEN AND UNDERSCREEN CONVEYOR**
  - 5' x 10' 2-deck (screen cloth optional)
  - 48" (1200mm) under screen conveyor
  - 24" (600mm) cross conveyor
  - Easily removed for maintenance
  - Lowers for transport
- RECIRCULATING CONVEYOR**
  - 18" (450mm) recirculating conveyor
  - Lowers for transport
- CHASSIS**
  - Sculpted frame design
  - 19.7" (500mm) tracks with dual drive
  - Balanced for zero cribbing
  - Dust suppression with manifold
- POWER UNIT**
  - Cummins QSL9 380hp / 258kw Tier 4 Final
  - 140gal / 530L fuel tank
  - 135gal / 511L oil reservoir

• **OPTIONS**

- Permanent cross belt magnet
- 30" (762mm) grizzly pre-screen with 1/2" spacing
- Grizzly bars with 2 1/2" spacing vs. grizzly fingers
- Bolt-on grizzly plate
- Lighting package mounted on engine housing
- CAT C9 375hp Tier 3 vs. std. (International only)
- 4-bar rotor with 4 reversible blow bars vs. 3 bar
- Wireless handheld remote control and receiver
- Belt scale
- Screen wire mesh (standard is high carbon)

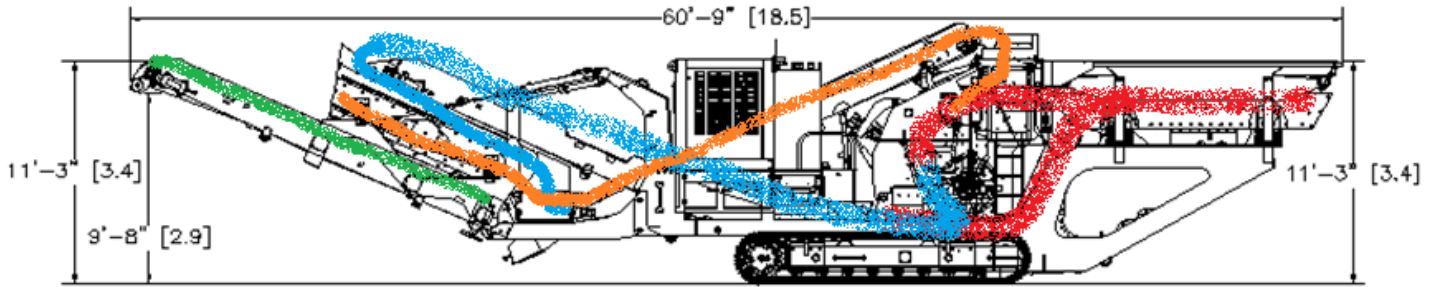

**GT440CC HSI PLANT**

• **PHYSICAL/OPERATING CHARACTERISTICS**

|                       |                |                                    |                       |
|-----------------------|----------------|------------------------------------|-----------------------|
| Operating Length..... | 60' 9" / 18.5m | Operating Width.....               | 11' 1" / 3.4m         |
| Travel Length.....    | 60' 9" / 18.5m | Travel Width.....                  | 11' 0" / 3.4m         |
| Operating Height..... | 13' 2" / 4.0m  | Feed Height.....                   | 11' 3" / 3.4m         |
| Travel Height.....    | 11' 5" / 3.5m  | Discharge Height.....              | 11' 3" / 3.4m         |
| Ground Clearance..... | 8" / 0.2m      | Side Discharge (optional).....     | 6' 1" / 1.8m          |
|                       |                | Unit Weight (est.) w/o options.... | 97,000 lb./ 43,998 kg |

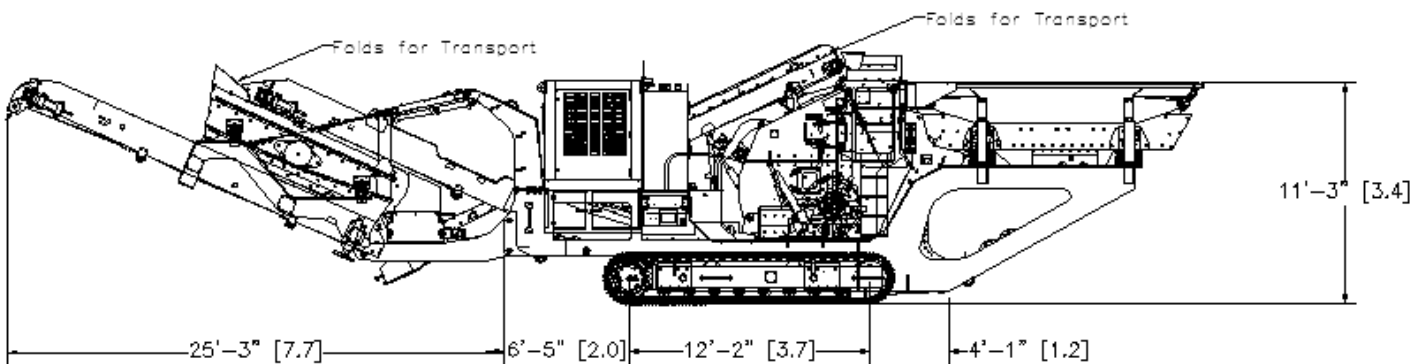
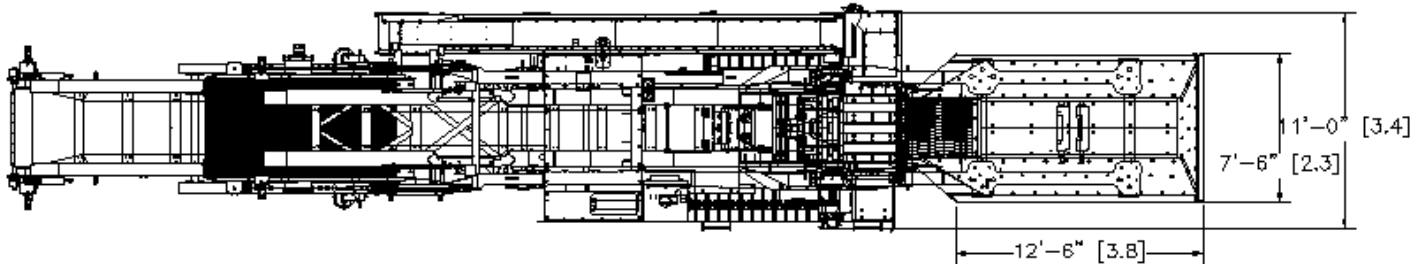

**Note:** Specifications are subject to change without notice.

Because KPI-JCI and Astec Mobile Screens may use in its catalog and literature, field photographs of its products which may have been modified by the owners, products furnished by KPI-JCI and Astec Mobile Screens may not necessarily be as illustrated therein. Also continuous design progress makes it necessary that specifications be subject to change without notice. All sales of the products of KPI-JCI and Astec Mobile Screens are subject to the provisions of its standard warranty. KPI-JCI and Astec Mobile Screens does not warrant or represent that its products meet any federal, state, or local statutes, codes, ordinances, rules, standards or other regulations, including OSHA and MSHA, covering safety, pollution, electrical wiring, etc. Compliance with these statutes and regulations is the responsibility of the user and will be dependent upon the area and the use to which the product is put by the user. In some photographs, guards may have been removed for illustrative purposes only. This equipment should not be operated without all guards attached in their normal position. Placement of guards and other safety equipment is often dependent upon the area and how the product is used. A safety study should be made by the user of the application, and, if required additional guards, warning signs and other safety devices should be installed by the user, wherever appropriate before operating the products.



700 W 21st. St., Yankton, SD 57078  
1-800-542-9311 Fax: 605-665-8858

Email: [mail@kpijci.com](mailto:mail@kpijci.com)  
[www.kpijci.com](http://www.kpijci.com)

Ref # - 370085 KPI GT440 1/20/15 Rev 0